



100V 15A 35ns Rectifier – MURC1510

Rev 1.0
27/12/22

Ultra-Fast recovery rectifier diode in bare die form

Features:

- Low leakage current
- High forward surge current capability
- Low forward voltage drop
- Robust construction
- High reliability tested grades.

Ordering Information

The following part suffixes apply:

- No suffix - MIL-STD-750 /2073 Visual Inspection
- “H” - MIL-STD-750 /2073 Visual Inspection
+ MIL-PRF-38534 Class H LAT
- “K” - MIL-STD-750 /2073 Visual Inspection
+ MIL-PRF-38534 Class K LAT

LAT = Lot Acceptance Test.

For further information on LAT process flows see below.

www.siliconsupplies.com/quality/bare-die-lot-qualification

Die Dimensions in μm (mils)

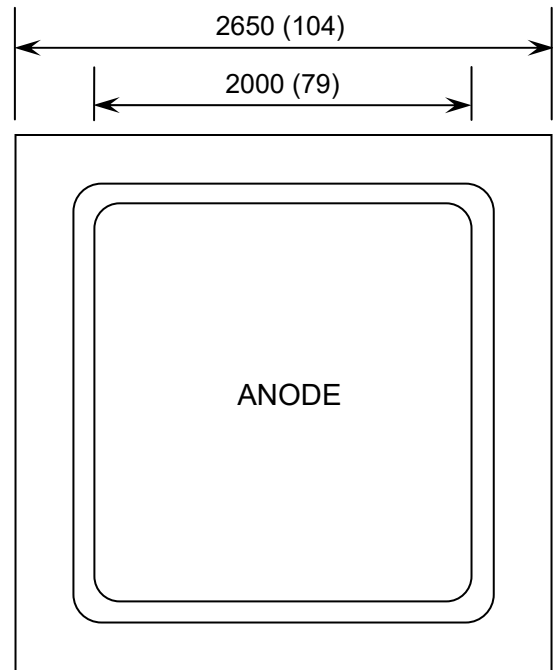

CHIP BACKSIDE IS CATHODE

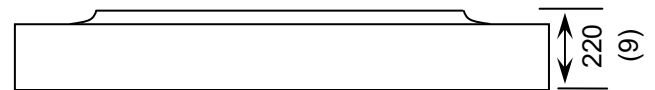

Supply Formats:

- Default – Die in Waffle Pack (100 per tray capacity)
- Sawn Wafer on Tape – By specific request
- Unsawn Wafer – By specific request
- With additional electrical selection – By specific request

Mechanical Specification

Die Size (Unsawn)	2650 x 2650 104.33 x 104.33	μm mils
Anode Pad Size	2000 x 2000 78.74 x 78.74	μm mils
Die Thickness	220 (± 20) 8.66 (± 0.79)	μm mils
Top Metal Composition	Al 7.5 μm	
Back Metal Composition	Ti/Ni/Ag	





100V 15A 35ns Rectifier – MURC1510

Rev 1.0
27/12/22

Absolute Maximum Ratings¹ $T_J = 25^\circ\text{C}$ unless otherwise stated

PARAMETER	SYMBOL	VALUE	UNIT
Peak Repetitive Reverse Voltage	V_{RRM}	100	V
Working Peak Repetitive Reverse Voltage	V_{RWM}		
DC Blocking Voltage	V_R		
RMS Reverse Voltage	$V_{R(RMS)}$	70	V
Average Forward Rectified Current, $T_J = 150^\circ\text{C}$	$I_{F(AV)}$	15	A
Peak Repetitive Forward Current ²	I_{FM}	30	A
Non-Repetitive Peak Forward Surge Current ³	I_{FSM}	250	A
Operating Junction temperature	T_J	-55 to 175	$^\circ\text{C}$
Storage Temperature Range	T_{STG}	-65 to 175	$^\circ\text{C}$

Electrical Characteristics $T_J = 25^\circ\text{C}$ unless otherwise stated

PARAMETER	SYMBOL	CONDITIONS	MIN	TYP	MAX	UNIT
Maximum Instantaneous Forward Voltage ⁴	V_F	$I_F = 15\text{A}, T_J = 25^\circ\text{C}$	-	-	1.05	V
		$I_F = 15\text{A}, T_J = 125^\circ\text{C}$	-	-	0.85	V
Maximum Instantaneous Reverse Leakage Current ⁴	$I_{RM} @ V_{RRM}$	$V_{RRM} = 100\text{V}, T_J = 25^\circ\text{C}$	-	0.003	0.05	μA
		$V_{RRM} = 100\text{V}, T_J = 125^\circ\text{C}$	-	7	20	μA
Reverse Recovery Time	t_{rr}	$I_F = 0.5\text{A}, I_R = 1.0\text{A}, I_{tr} = 0.25\text{A}$	-	17	35	ns
Junction Capacitance	C_J	$V_R = 4\text{V}, f = 1.0\text{MHz}$	-	150	-	pF

1. Operation above the absolute maximum rating may cause device failure. Operation at the absolute maximum ratings, for extended periods, may reduce device reliability. 2. $V_R = 100\text{V}$, Square Wave, 20kHz Pulse Width = 3.8ms 3. Surge applied at rated load conditions halfwave, single phase, 60Hz 4. Pulse Test: Pulse Width = 300s, Duty Cycle $\leq 2.0\%$

Typical Characteristics $T_J = 25^\circ\text{C}$ unless otherwise stated

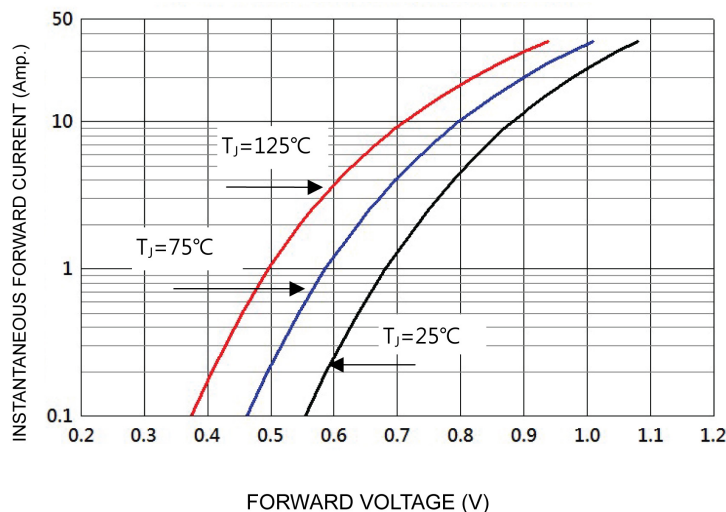

FIGURE 1. Forward Voltage Characteristics





100V 15A 35ns Rectifier – MURC1510

Typical Characteristics Continued $T_J = 25^\circ\text{C}$ unless otherwise stated

Rev 1.0
27/12/22

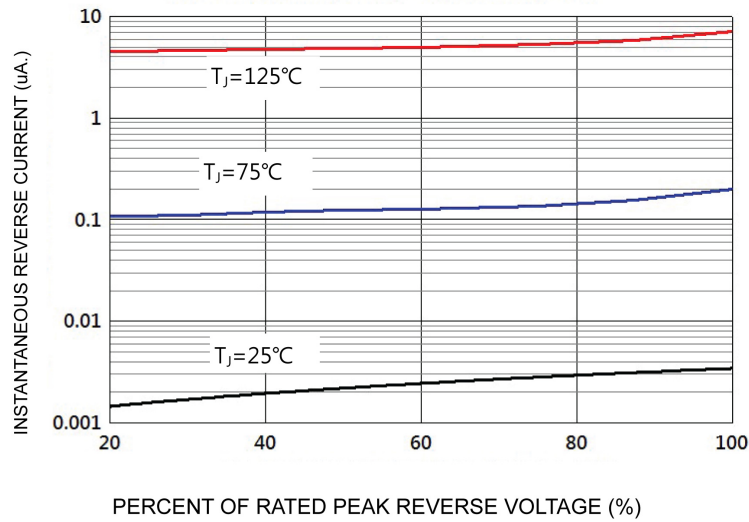

FIGURE 2. Reverse Current Versus Reverse Voltage



FIGURE 3. Peak Forward Surge Current Versus Cycles at 60 Hz





100V 15A 35ns Rectifier – MURC1510

Rev 1.0
27/12/22

Typical Characteristics Continued $T_J = 25^\circ\text{C}$ unless otherwise stated

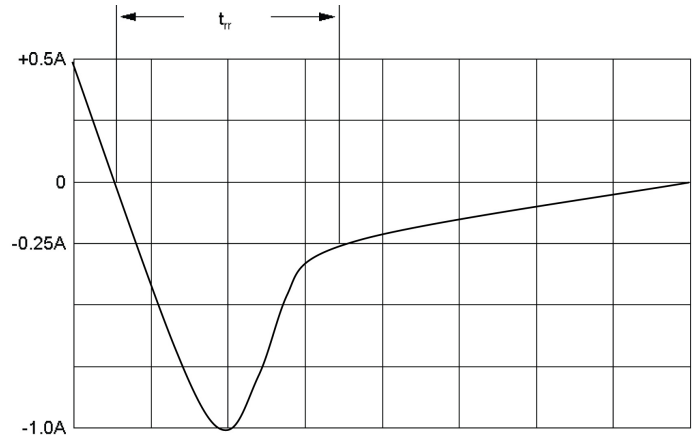
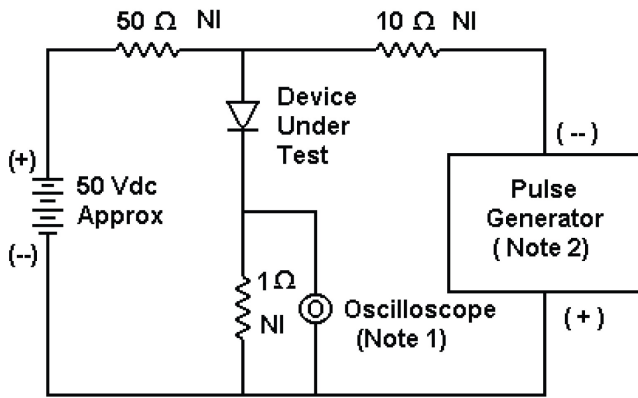

- Notes:
1. Rise Time = 7 ns max. Input Impedance = 1 M Ω , 22 pF
 2. Rise Time = 10 ns max. Input Impedance = 50 Ω

Set time base for 10/20 ns/cm

FIGURE 4. Reverse Recovery Time Characteristics + Test Circuit

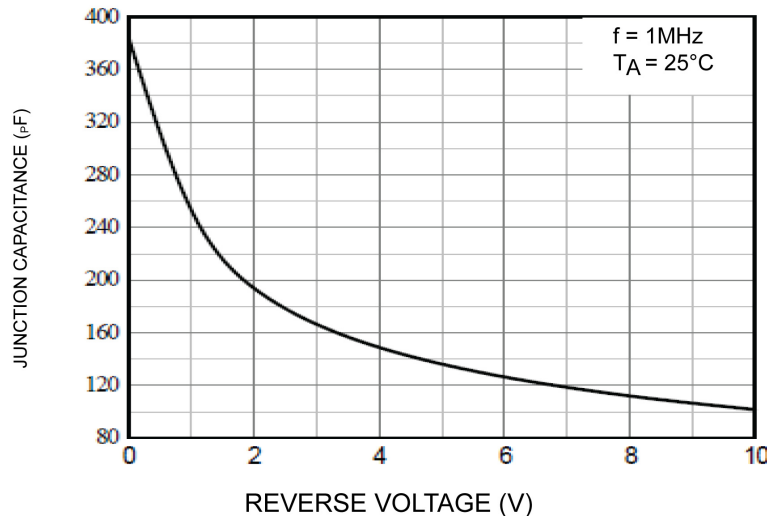

FIGURE 5. Typical Junction Capacitance

DISCLAIMER: The information given in this document shall in no event be regarded as a guarantee of conditions or characteristics. With respect to any examples or hints given herein, any typical values stated herein and/or any information regarding the application of the device, Silicon Supplies Ltd hereby disclaims any and all warranties and liabilities of any kind.

LIFE SUPPORT POLICY: Silicon Supplies Ltd components may be used in life support devices or systems only with the express written approval of Silicon Supplies Ltd, if a failure of such components can reasonably be expected to cause the failure of that life support device or system or to affect the safety or effectiveness of that device or system. Life support devices or systems are intended to be implanted in the human body or to support and/or maintain and sustain and/or protect human life. If they fail, it is reasonable to assume that the health of the user or other persons may be endangered.

