



Quad Differential Comparator – LM339A

Low power, low offset voltage quad comparator in bare die form

Rev 1.0
04/05/18

Description

LM339A consists of x4 independent precision voltage comparators, each with low offset voltages of 2mV max. The device operates on single or split power supply over a wide voltage range. Common mode input voltage range includes ground even in single supply operation. Supply current drain is independent of supply voltage, useful for low power applications. This device directly interfaces CMOS, TTL & MOS with split supply. Typical uses include level detection, low-level sensing, A/D conversion, VCOs, MOS clock generators, high voltage logic gates & multivibrators.

Features:

- Single-Supply range: 2-36V
- Split-Supply range: $\pm 1.0V$ to $\pm 18V$
- Low Input Offset Voltage 2mV maximum
- Common mode input voltage includes ground
- Very low supply current independent of supply voltage (1 mW/comparator at +5V)
- Very Low Input Offset Current
- TTL, DTL, ECL, MOS, CMOS compatible outputs

Ordering Information

The following part suffixes apply:

- No suffix - MIL-STD-883 /2010B Visual Inspection

For High Reliability versions of this product please see

[LM139](#) and [LM139A](#)

Die Dimensions in μm (mils)

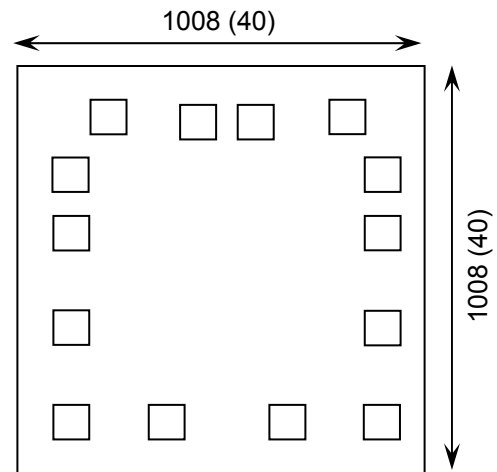

Supply Formats:

- Default – Die in Waffle Pack (400 per tray capacity)
- Sawn Wafer on Tape – On request
- Unsawn Wafer – On request
- Die Thickness \leftrightarrow 280 μm (11 Mils) – On request
- Assembled into Ceramic Package – On request

Mechanical Specification

Die Size (Unsawn)	1008 x 1008 40 x 40	μm mils
Minimum Bond Pad Size	94 x 94 3.7 x 3.7	μm mils
Die Thickness	280 (± 10) 11.02 (± 0.39)	μm mils
Top Metal Composition	Al 1%Si 1.1 μm	
Back Metal Composition	N/A – Bare Si	





Quad Differential Comparator – LM339A

Rev 1.0
04/05/18

Pad Layout and Functions

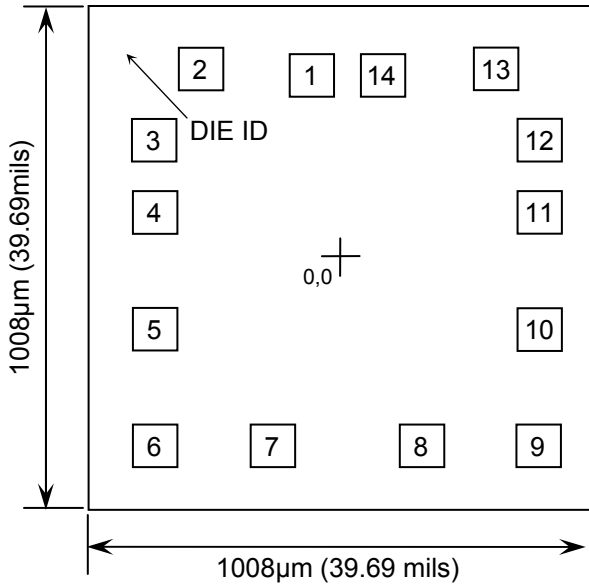

PAD	FUNCTION	COORDINATES (µm)	
		X	Y
1	OUTPUT 2	-57	391
2	OUTPUT 1	-299	405
3	V _{CC}	-398.5	251
4	-INPUT 1	-396.5	97
5	+INPUT 1	-396.5	-155
6	-INPUT 2	-395	-405
7	+INPUT 2	-143	-405
8	-INPUT 3	179.5	-405
9	+INPUT 3	431.5	-405
10	-INPUT 4	433	-155
11	+INPUT 4	433	97
12	GND	435	251
13	OUTPUT 4	339.5	405
14	OUTPUT 3	97	391

CHIP BACK POTENTIAL IS GND OR FLOAT

Logic Diagram (Single channel)

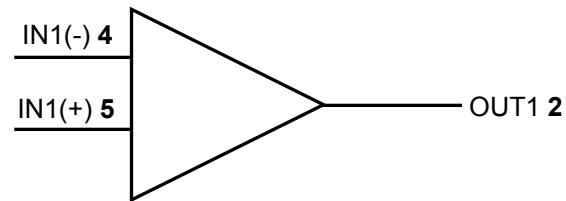

PAD 3 = V_{CC}
PAD 12 = GND

Schematic (Single channel)

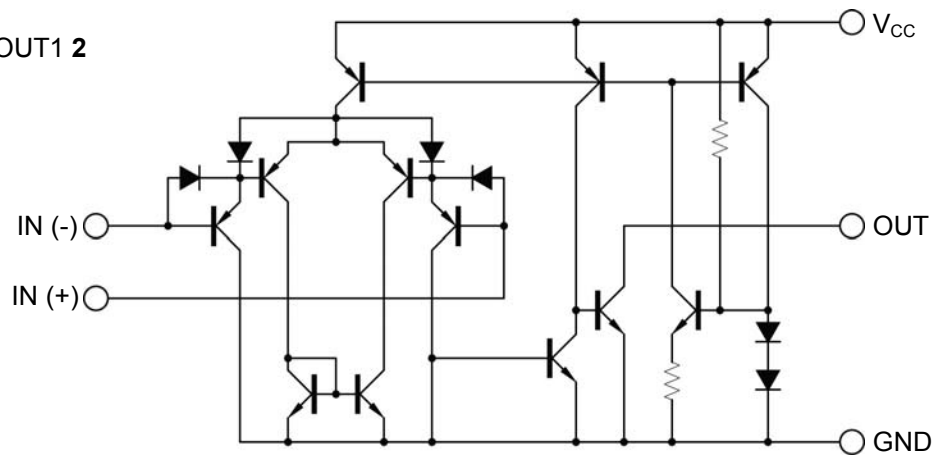



Quad Differential Comparator – LM339A

Rev 1.0
04/05/18

Absolute Maximum Ratings¹

PARAMETER	SYMBOL	VALUE	UNIT
Supply Voltage – Single Supply	V_{CC}	36	V
Supply Voltage – Split Supply		± 18	V
Input Differential Voltage Range	V_{IDR}	36	V
Input Common Mode Voltage Range	V_{ICR}	-0.3 to V_{CC}	V
Output Short Circuit to Ground	-	Continuous	-
Input Current (per pad) ²	I_{IN}	50	mA
Junction Temperature	T_J	150	°C
Power Dissipation in Still Air ³	P_D	756	mW

1. Operation above the absolute maximum rating may cause device failure. Operation at the absolute maximum ratings, for extended periods, may reduce device reliability.
2. $V_{IN} < -0.3V$. This input current exists when voltage is driven negative at any of the input leads
3. Assembled in 14 lead PDIP

Recommended Operating Conditions

PARAMETER	SYMBOL	MIN	MAX	UNITS
DC Supply Voltage	V_{CC}	2	30	V
Operating Temperature	T_A	0	+70	°C

DC Electrical Characteristics ($V_{CC} = 5V$, $T_A = 25^\circ C$ unless otherwise specified)

PARAMETER	SYMBOL	CONDITIONS	LIMITS			UNITS	
			MIN	TYP	MAX		
Input Offset Voltage	V_{IO}	$V_O = 1.4V$, $R_S = 0\Omega$; $V_{CC} = 5-30V$, $V_{ICR} = 0V - (V_{CC} - 1.5V)$	25°C	-	1	2	mV
			70°C	-	-	4	
Input Bias Current	I_B	$V_O = 1.4V$, $R_S = 0\Omega$; $V_{CC} = 5-30V$, $V_{ICR} = 0V - (V_{CC} - 1.5V)$	25°C	-	25	250	nA
			70°C	-	-	400	
Input Offset Current	I_{IO}	$V_O = 1.4V$, $R_S = 0\Omega$; $V_{CC} = 5-30V$, $V_{ICR} = 0V - (V_{CC} - 1.5V)$	25°C	-	5	50	nA
			70°C	-	-	150	
Input Common Mode Voltage Range	V_{ICR}	$V_{CC} = 5-30V$	25°C	0	-	$V_{CC} - 1.5$	V
			70°C	0	-	$V_{CC} - 2.0$	
Supply Current	I_{CC}	$R_L = \infty$, $V_{CC} = 5V$	-	1.1	2	mA	
		$R_L = \infty$, $V_{CC} = 36V$	-	-	2.5		
Voltage Gain	A_{VOL}	$V_{CC} = 15V$, $R_L \geq 15k\Omega$, $T_A = 25^\circ C$, $V_O = 1V$ to $11V$	50	200	-	V/mV	
Large Signal Response Time	t_1	$V_{IN} = TTL$ Logic Swing, $V_{REF} = 1.4V$, $V_{RL} = 5V$ $R_L = 5.1k\Omega$	-	300	-	ns	
Response Time	t_2	$R_L = 5.1k\Omega$, $V_{RL} = 5V$	-	1.3	-	μS	





Quad Differential Comparator – LM339A

Rev 1.0
04/05/18

DC Electrical Characteristics ($V_{CC} = 5V$, $T_A = 25^\circ C$ unless otherwise specified)

PARAMETER	SYMBOL	CONDITIONS	LIMITS			UNITS	
			MIN	TYP	MAX		
Output Sink Current	I_{SINK}	$V_{I(-)} = 1V$, $V_{I(+)} = 0V$, $V_O \leq 1.5V$	6	18	-	mA	
Saturation Voltage	V_{SAT}	$V_{I(-)} = 1V$, $V_{I(+)} = 0V$ $I_{SINK} \leq 4mA$	25°C	-	140	400	mV
			70°C	-	-	700	
Output Leakage Current	I_{OL}	$V_{I(+)} = 1V$, $V_{I(-)} = 0V$	$V_O = 5V$, $T_A = 25^\circ C$	-	0.1	-	nA
			$V_O = 30V$, $T_A = 70^\circ C$	-	-	1000	
Differential Input Voltage Range	V_{IDR}	All $V_{IN} \geq GND$ or V- Supply (if used)	-	-	V_{CC}	V	

Typical Characteristics

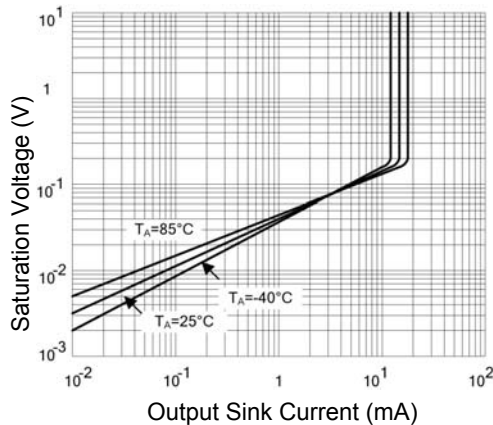

FIGURE 1. Output Saturation Voltage vs Output Sink Current

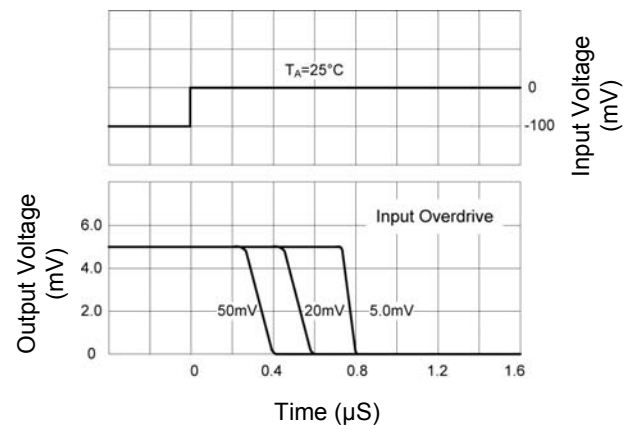

FIGURE 2. Input Overdrive Response time – Negative transition

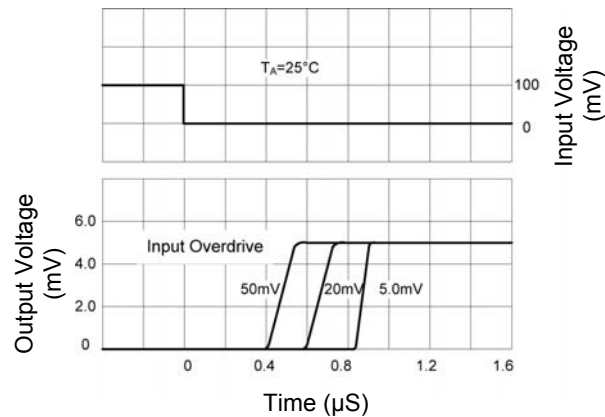

FIGURE 3. Input Overdrive Response time – Positive transition





Quad Differential Comparator – LM339A

Rev 1.0
04/05/18

Typical Applications

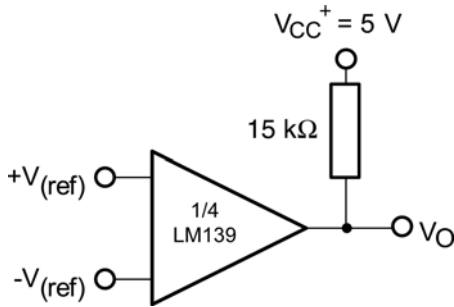

FIGURE 4. Basic Comparator

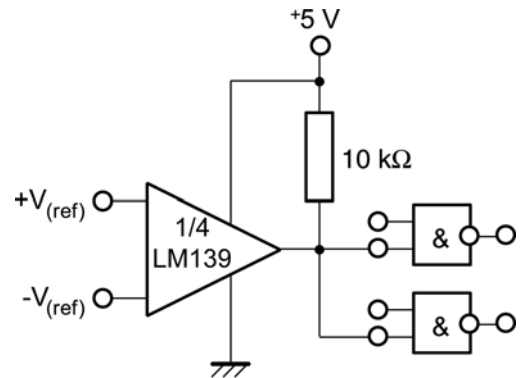

FIGURE 5. Driving TTL

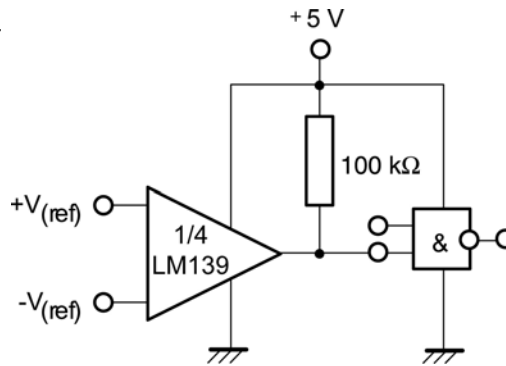

FIGURE 6. Driving CMOS

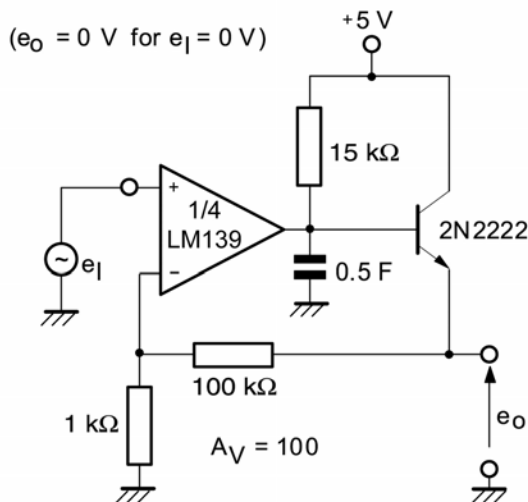

FIGURE 7. Low frequency Operational Amplifier V1

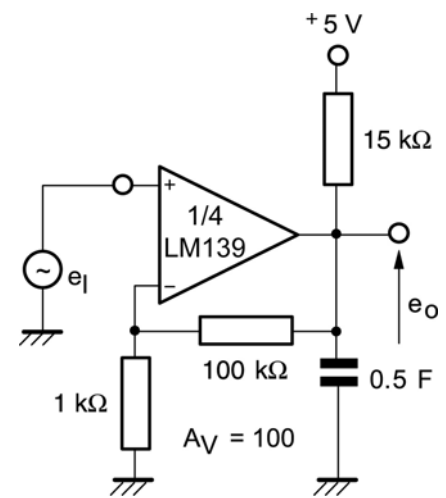

FIGURE 8. Low frequency Operational Amplifier V2





Quad Differential Comparator – LM339A

Rev 1.0
04/05/18

Typical Applications continued

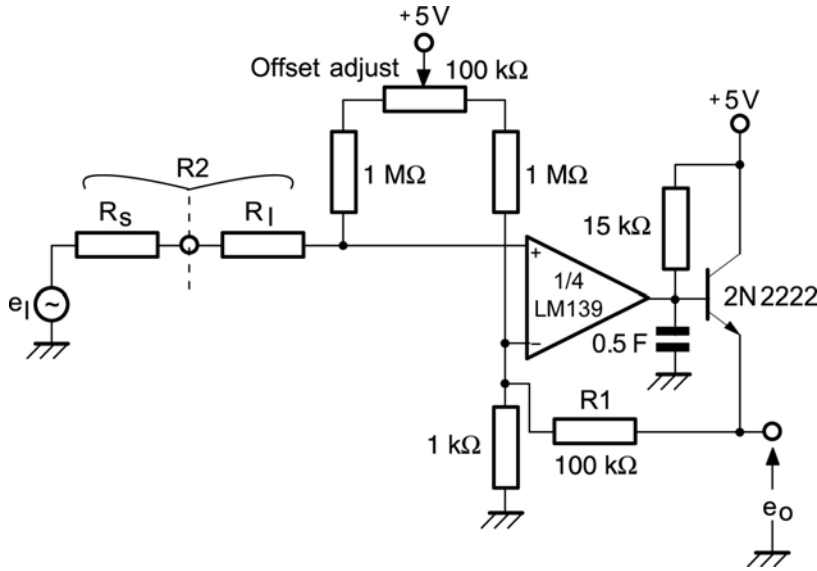

FIGURE 9. Low frequency Op-Amp with Offset adjust

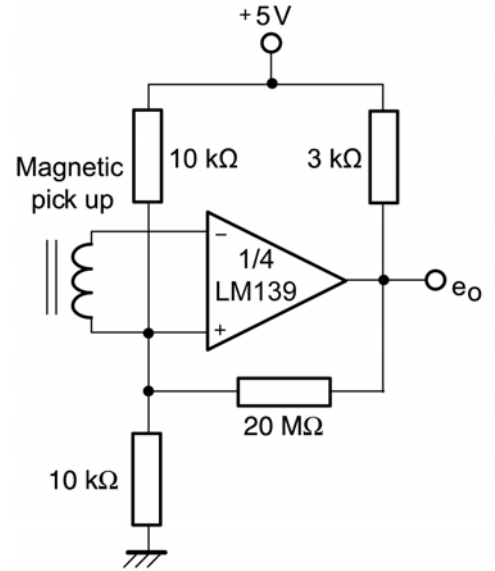

FIGURE 10. Transducer Amplifier

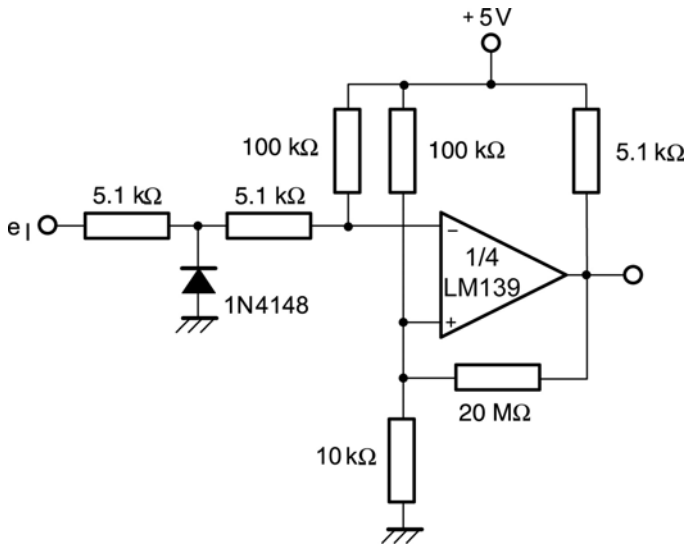

FIGURE 11. Zero crossing detector (single power supply)

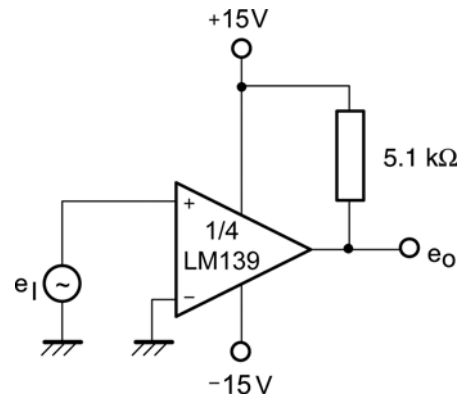

FIGURE 12. Zero crossing detector (split power supply)





Quad Differential Comparator – LM339A

Rev 1.0
04/05/18

Typical Applications continued

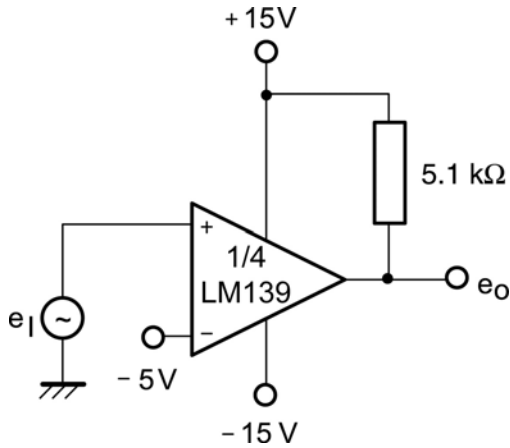

FIGURE 13. Comparator with a negative reference

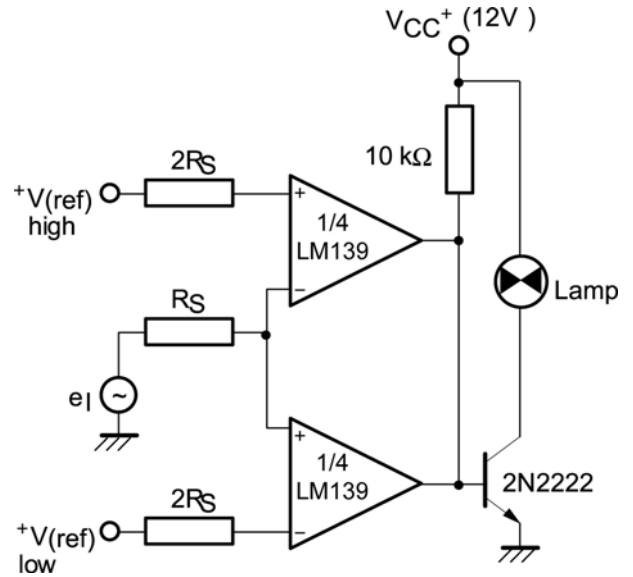

FIGURE 14. Limit Comparator

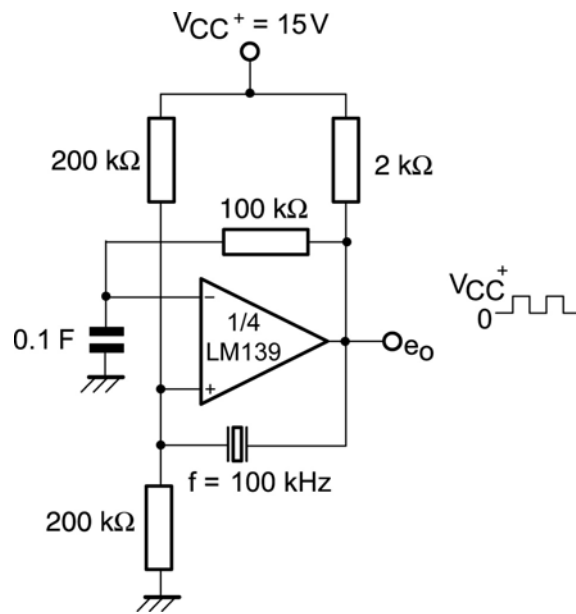

FIGURE 15. Crystal controlled Comparator





Quad Differential Comparator – LM339A

Rev 1.0
04/05/18

Typical Applications continued

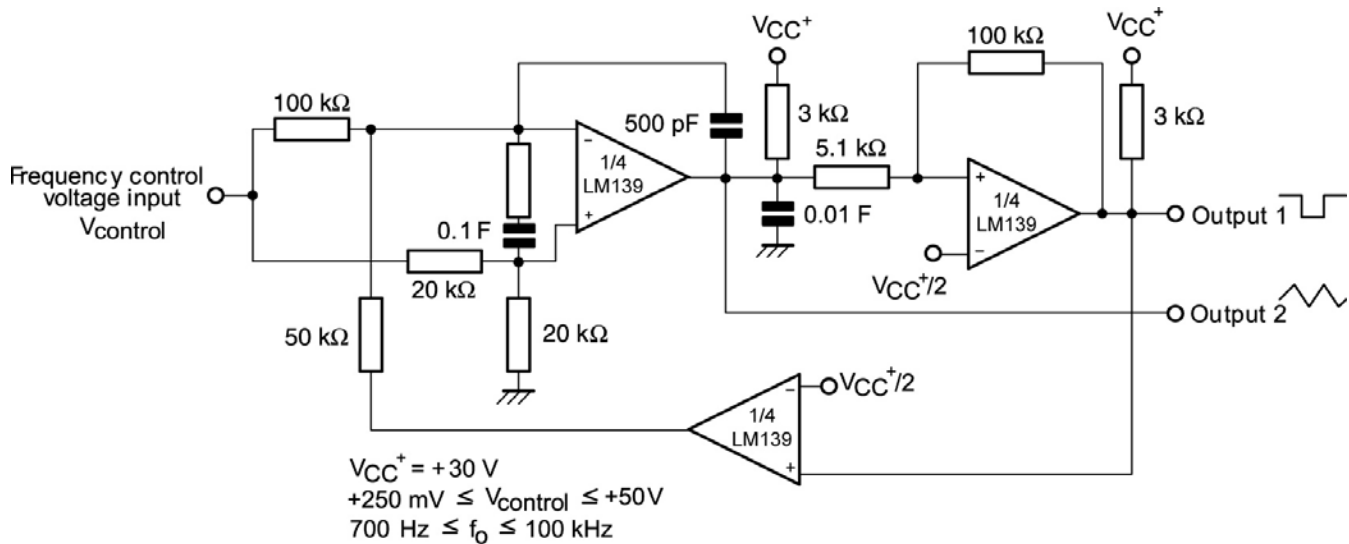

FIGURE 16. Two-decade High-Frequency VCO

DISCLAIMER: The information given in this document shall in no event be regarded as a guarantee of conditions or characteristics. With respect to any examples or hints given herein, any typical values stated herein and/or any information regarding the application of the device, Silicon Supplies Ltd hereby disclaims any and all warranties and liabilities of any kind.

LIFE SUPPORT POLICY: Silicon Supplies Ltd components may be used in life support devices or systems only with the express written approval of Silicon Supplies Ltd, if a failure of such components can reasonably be expected to cause the failure of that life support device or system or to affect the safety or effectiveness of that device or system. Life support devices or systems are intended to be implanted in the human body or to support and/or maintain and sustain and/or protect human life. If they fail, it is reasonable to assume that the health of the user or other persons may be endangered.

