



High Speed CMOS Logic – 74HC02

Quad 2-Input NOR Gates in bare die form

Rev 1.0
22/04/19

Description

The 74HC02 2-Input NOR Gate is fabricated on a .35µm advanced CMOS process combining high speed LSTTL performance with CMOS low power. The device performs the Boolean function $Y = (A + B)$ or $Y = \bar{A} \cdot \bar{B}$ in positive logic. Internal circuitry comprises of three stages and includes buffered output for high noise immunity and stability. Inputs are compatible with standard CMOS outputs; with pull-up resistors, they are compatible with LSTTL outputs. The product die size is significantly smaller than industry peers due to its re-design and production using a more advanced CMOS process.

Features:

- Output Drive Capability: 10 LSTTL Loads
- Low Input Current: 1µA
- Outputs directly interface CMOS, NMOS and TTL
- Operating Voltage Range: 2V to 6V
- Function compatible with 54LS02
- High Noise Immunity CMOS process.

Ordering Information

The following part suffixes apply:

- No suffix - MIL-STD-883 /2010B Visual Inspection

For High Reliability versions of this product please see

[54HC02](#)

Die Dimensions in µm (mils)

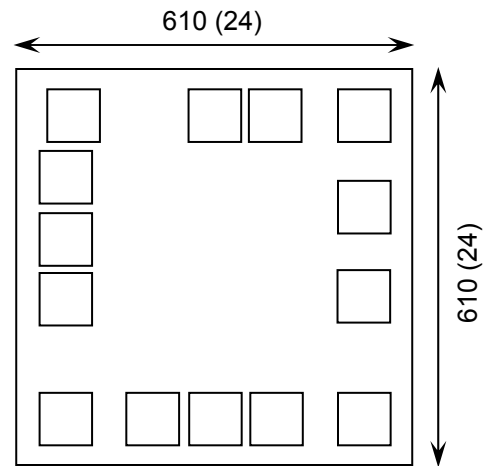

Supply Formats:

- Default – Die in Waffle Pack (400 per tray capacity)
- Sawn Wafer on Tape – On request
- Unsawn Wafer – On request
- Die Thickness <=> 350µm(14 Mils) – On request
- Assembled into Ceramic Package – On request

Mechanical Specification

Die Size (Unsawn)	610 x 610 24 x 24	µm mils
Minimum Bond Pad Size	85 x 85 3.35 x 3.35	µm mils
Die Thickness	350 (±20) 13.78 (±0.79)	µm mils
Top Metal Composition	Al 1%Si 1.1µm	
Back Metal Composition	N/A – Bare Si	





High Speed CMOS Logic – 74HC02

Rev 1.0
22/04/19

Pad Layout and Functions

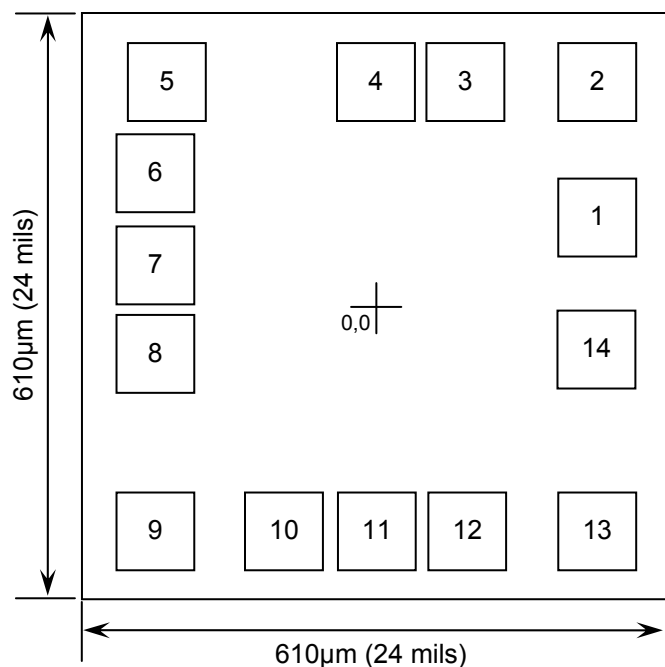

PAD	FUNCTION	COORDINATES (µm)	
		X	Y
1	1Y	230	95
2	1A	230	230
3	1B	95	230
4	2Y	0	230
5	2A	-220	230
6	2B	-230	140
7	GND	-230	45
8	3A	-230	-52
9	3B	-230	-230
10	3Y	-95	-230
11	4A	0	-230
12	4B	95	-230
13	4Y	230	-230
14	V _{CC}	230	-45

CONNECT CHIP BACK TO V_{CC} OR FLOAT

Logic Diagram

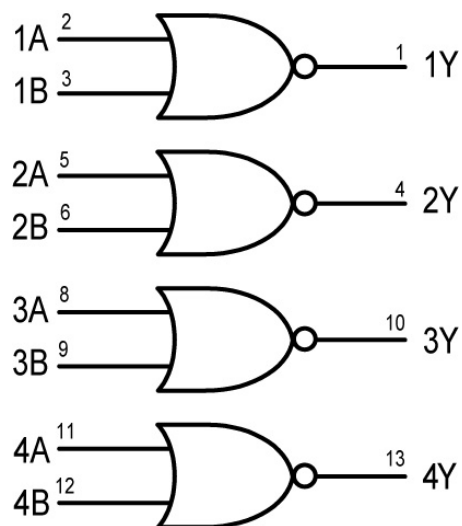

Pad 14 = V_{CC}
Pad 7 = GND

Truth Table

INPUTS		OUTPUT
A	B	Y
L	L	H
L	H	L
H	L	L
H	H	L

H = High level (steady state)
L = Low level (steady state)





High Speed CMOS Logic – 74HC02

Rev 1.0

22/04/19

Absolute Maximum Ratings¹

PARAMETER	SYMBOL	VALUE	UNIT
DC Supply Voltage (Referenced to GND)	V_{CC}	-0.5 to +7.0	V
DC Input Voltage (Referenced to GND)	V_{IN}	-0.5 to $V_{CC} + 0.5$	V
DC Output Voltage (Referenced to GND)	V_{OUT}	-0.5 to $V_{CC} + 0.5$	V
DC Input Current	I_{IN}	±20	mA
DC Output Current, per pad	I_{OUT}	±25	mA
DC Supply Current, V_{CC} or GND	I_{CC}	±50	mA
Power Dissipation in Still Air ²	P_D	750	mW
Storage Temperature Range	T_{STG}	-65 to 150	°C

1. Operation above the absolute maximum rating may cause device failure. Operation at the absolute maximum ratings, for extended periods, may reduce device reliability. 2. Measured in plastic DIP package, results in die form are dependent on die attach and assembly method.

Recommended Operating Conditions³ (Voltages referenced to GND)

PARAMETER	SYMBOL	MIN	MAX	UNITS	
Supply Voltage	V_{CC}	2	6	V	
DC Input or Output Voltage	V_{IN}, V_{OUT}	0	V_{CC}	V	
Operating Temperature Range	T_J	0	+85	°C	
Input Rise or Fall Times	t_r, t_f	$V_{CC} = 2V$	0	1000	ns
		$V_{CC} = 4.5V$	0	500	
		$V_{CC} = 6.0V$	0	400	

3. This device contains protection circuitry to guard against damage due to high static voltages or electric fields. However, precautions must be taken to avoid applications of any voltage higher than maximum rated voltages to this high-impedance circuit. For proper operation, V_{IN} and V_{OUT} should be constrained to the range $GND \leq (V_{IN} \text{ or } V_{OUT}) \leq V_{CC}$. Unused inputs must always be tied to an appropriate logic voltage level (e.g., either GND or V_{CC}). Unused outputs must be left open.

DC Electrical Characteristics (Voltages Referenced to GND)

PARAMETER	SYMBOL	V_{CC}	CONDITIONS	LIMITS			UNITS
				25°C	85°C	FULL RANGE ⁴	
Minimum High-Level Input Voltage	V_{IH}	2.0V	$V_{OUT} = 0.1V \text{ or } V_{CC} - 0.1V$ $ I_{OUT} \leq 20\mu A$	1.5	1.5	1.5	V
		3.0V		2.1	2.1	2.1	
		4.5V		3.15	3.15	3.15	
		6.0V		4.2	4.2	4.2	
Maximum Low-Level Input Voltage	V_{IL}	2.0V	$V_{OUT} = 0.1V \text{ or } V_{CC} - 0.1V$ $ I_{OUT} \leq 20\mu A$	0.5	0.5	0.5	V
		3.0V		0.9	0.9	0.9	
		4.5V		1.35	1.35	1.35	
		6.0V		1.8	1.8	1.8	

4. $0^\circ C \leq T_J \leq +85^\circ C$





High Speed CMOS Logic – 74HC02

Rev 1.0

22/04/19

DC Electrical Characteristics Continued (Voltages Referenced to GND)

PARAMETER	SYMBOL	V _{CC}	CONDITIONS	LIMITS			UNITS
				25°C	85°C	FULL RANGE ⁴	
Minimum High-Level Output Voltage	V _{OH}	2.0V	V _{IN} = V _{IH} or V _{IL} I _{OUT} ≤ 20μA	1.9	1.9	1.9	V
		4.5V		4.4	4.4	4.4	
		6.0V		5.9	5.9	5.9	
		3.0V	V _{IN} = V _{IH} or V _{IL} I _{OUT} ≤ 2.4mA	2.48	2.34	2.34	V
		4.5V		3.98	3.84	3.84	
		6.0V		5.48	5.34	5.34	
Maximum Low-Level Output Voltage	V _{OL}	2.0V	V _{IN} = V _{IL} or V _{IL} I _{OUT} ≤ 20μA	0.1	0.1	0.1	V
		4.5V		0.1	0.1	0.1	
		6.0V		0.1	0.1	0.1	
		3.0V	V _{IN} = V _{IL} or V _{IL} I _{OUT} ≤ 2.4mA	0.26	0.33	0.33	V
		4.5V		0.26	0.33	0.33	
		6.0V		0.26	0.33	0.33	
Maximum Input Leakage Current	I _{IN}	6.0V	V _{IN} = V _{CC} or GND	±0.1	±1.0	±1.0	μA
Maximum Quiescent Supply Leakage Current	I _{CC}	6.0V	V _{IN} = V _{CC} or GND I _{OUT} = 0μA	1	10	10	μA

AC Electrical Characteristics⁵

PARAMETER	SYMBOL	V _{CC}	CONDITIONS	LIMITS			UNITS
				25°C	85°C	FULL RANGE ⁴	
Maximum Propagation Delay, Input A or B to Output Y (Figure 1,2)	t _{PLH} , t _{PHL}	2.0V	C _L = 50pF, t _r = t _f = 6ns	75	95	95	ns
		3.0V		30	40	40	
		4.5V		15	19	19	
		6.0V		13	16	16	
Maximum Output Rise and Fall Time, Any Output (Figure 1,2)	t _{TLH} , t _{THL}	2.0V	C _L = 50pF, t _r = t _f = 6ns	75	95	95	ns
		3.0V		30	40	40	
		4.5V		15	19	19	
		6.0V		13	16	16	

5. Not production tested in die form, characterized by chip design and tested in package.





High Speed CMOS Logic – 74HC02

Rev 1.0
22/04/19

AC Electrical Characteristics Continued⁵

PARAMETER	SYMBOL	V _{CC}	CONDITIONS	LIMITS			UNITS
				25°C	85°C	FULL RANGE ⁴	
Maximum Input Capacitance	C _{IN}	-	-	10	10	10	pF
Power Dissipation Capacitance Per Gate ⁶	C _{PD}	-	T _A = 25°C, V _{CC} = 5.0V	TYPICAL			pF
				22			

6. Used to determine the no-load dynamic power consumption: $P_D = C_{PD} V_{CC}^2 f + I_{CC} V_{CC}$.

Switching Waveform

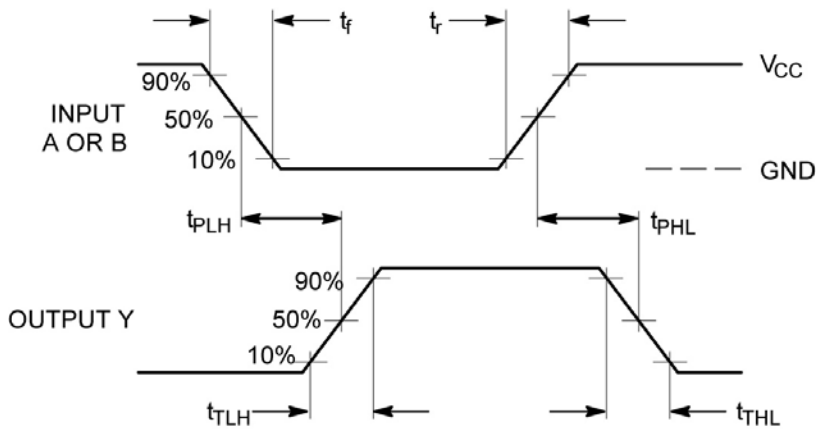
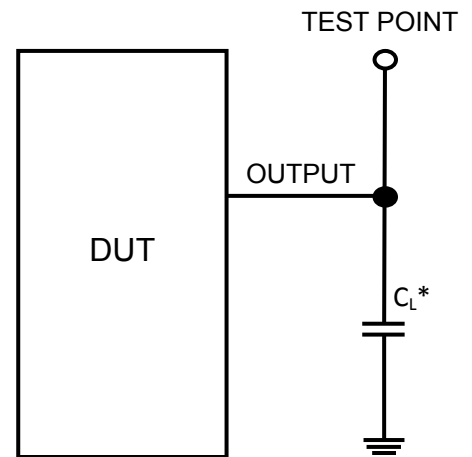

Figure 1 – Propagation Delay & Output Transition Time

Test Circuit



* Includes all probe and jig capacitance

Figure 2

DISCLAIMER: The information given in this document shall in no event be regarded as a guarantee of conditions or characteristics. With respect to any examples or hints given herein, any typical values stated herein and/or any information regarding the application of the device, Silicon Supplies Ltd hereby disclaims any and all warranties and liabilities of any kind.

LIFE SUPPORT POLICY: Silicon Supplies Ltd components may be used in life support devices or systems only with the express written approval of Silicon Supplies Ltd, if a failure of such components can reasonably be expected to cause the failure of that life support device or system or to affect the safety or effectiveness of that device or system. Life support devices or systems are intended to be implanted in the human body or to support and/or maintain and sustain and/or protect human life. If they fail, it is reasonable to assume that the health of the user or other persons may be endangered.

