



Advanced CMOS TTL Input – 54ACT32

Quad 2-Input OR Gate with LSTTL compatible inputs in bare die form

Rev 1.1
08/11/2022

Description

The 54ACT32 quad 2-input OR gate is produced on a 1.5µm 5V CMOS process and provides four independent 2-input OR gates with standard push-pull outputs. The device gates perform the Boolean function $Y = \overline{A} \bullet \overline{B}$ or $Y = A + B$. Device inputs directly accept LSTTL or CMOS. All inputs are protected against ESD and excess voltage transients. This device is designed specifically to interface both Bipolar Logic and High Speed CMOS systems.

Features:

- Inputs directly accept TTL
- Outputs directly interface CMOS, NMOS and TTL
- Outputs Source/Sink 24 mA
- Low Input Current: 1µA
- Functionally compatible with bipolar 54F32
- Lower power alternative to bipolar logic
- Full Military Temperature Range

Ordering Information

The following part suffixes apply:

- No suffix - MIL-STD-883 /2010B Visual Inspection
- “H” - MIL-STD-883 /2010B Visual Inspection + MIL-PRF-38534 Class H LAT
- “K” - MIL-STD-883 /2010A Visual Inspection (Space) + MIL-PRF-38534 Class K LAT

LAT = Lot Acceptance Test.

For further information on LAT process flows see below.

www.siliconsupplies.com/quality/bare-die-lot-qualification

Die Dimensions in µm (mils)

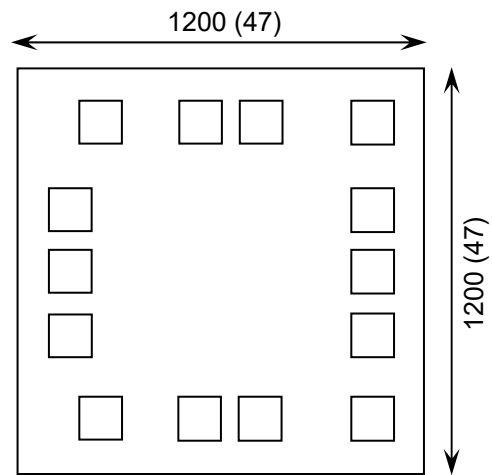

Supply Formats:

- Default – Die in Waffle Pack (400 per tray capacity)
- Sawn Wafer on Tape – On request
- Unsawn Wafer – On request
- Die Thickness <> 350µm(14 Mils) – On request
- Assembled into Ceramic Package – On request

Mechanical Specification

Die Size (Unsawn)	1200 x 1200 47 x 47	µm mils
Minimum Bond Pad Size	120 x 120 4.72 x 4.72	µm mils
Die Thickness	350 (±20) 13.78 (±0.79)	µm mils
Top Metal Composition	Al 1%Si 1.1µm	
Back Metal Composition	N/A – Bare Si	





Advanced CMOS TTL Input – 54ACT32

Rev 1.1
08/11/2022

Pad Layout and Functions

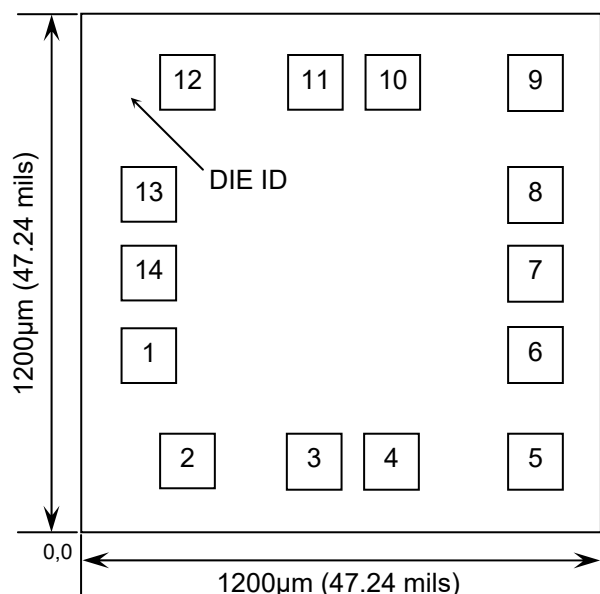

PAD	FUNCTION	COORDINATES (µm)	
		X	Y
1	1A	100	350
2	1B	150	100
3	1Y	480	100
4	2A	660	100
5	2B	990	100
6	2Y	990	350
7	GND	990	540
8	3Y	990	720
9	3A	990	980
10	3B	660	980
11	4Y	480	980
12	4A	150	980
13	4B	100	720
14	V _{CC}	100	540

CONNECT CHIP BACK TO V_{CC} OR FLOAT

Logic Diagram

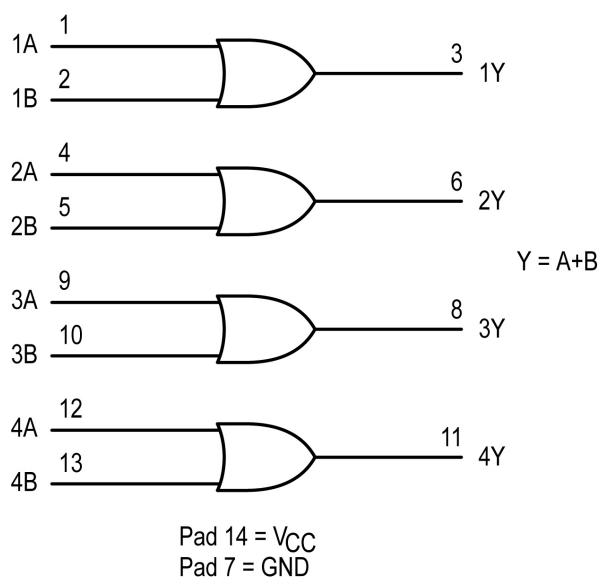

Function Table

INPUTS		OUTPUT
A	B	Y
L	L	L
L	H	H
H	L	H
H	H	H

H = High level (steady state)
L = Low level (steady state)





Advanced CMOS TTL Input – 54ACT32

Rev 1.1
08/11/2022

Absolute Maximum Ratings¹

PARAMETER	SYMBOL	VALUE	UNIT
DC Supply Voltage (Referenced to GND)	V_{CC}	-0.5 to +7.0	V
DC Input Voltage (Referenced to GND)	V_{IN}	-0.5 to $V_{CC} + 0.5$	V
DC Output Voltage (Referenced to GND)	V_{OUT}	-0.5 to $V_{CC} + 0.5$	V
DC Input Current	I_{IN}	±20	mA
DC Output Current, per pad	I_{OUT}	±50	mA
DC Supply Current, V_{CC} or GND, per pad	I_{CC}	±50	mA
Power Dissipation in Still Air ²	P_D	750	mW
Storage Temperature Range	T_{STG}	-65 to 150	°C

1. Operation above the absolute maximum rating may cause device failure. Operation at the absolute maximum ratings, for extended periods, may reduce device reliability. 2. Measured in plastic DIP package, results in die form are dependent on die attach and assembly method.

Recommended Operating Conditions³ (Voltages Referenced to GND)

PARAMETER	SYMBOL	MIN	MAX	UNITS	
DC Supply Voltage	V_{CC}	4.5	5.5	V	
DC Input or Output Voltage	V_{IN}, V_{OUT}	0	V_{CC}	V	
Operating Temperature Range	T_J	-55	+125	°C	
Output current - High	I_{OH}	-	-24	mA	
Output current - Low	I_{OL}	-	24	mA	
Input Rise or Fall rate (V_{IN} from 0.8V to 2V)	$V_{CC} = 4.5V$	$\Delta t / \Delta V$	0	10	ns/V
	$V_{CC} = 5.5V$		0	8	

3. This device contains protection circuitry to guard against damage due to high static voltages or electric fields. However, precautions must be taken to avoid applications of any voltage higher than maximum rated voltages to this high-impedance circuit. For proper operation, V_{IN} and V_{OUT} should be constrained to the range $GND \leq (V_{IN} \text{ or } V_{OUT}) \leq V_{CC}$. Unused inputs must always be tied to an appropriate logic voltage level (e.g., either GND or V_{CC}). Unused outputs must be left open.

DC Electrical Characteristics (Voltages referenced to GND)

PARAMETER	SYMBOL	V_{CC}	CONDITIONS	LIMITS			UNITS
				25°C	85°C	FULL RANGE ⁴	
Minimum High-Level Input Voltage	V_{IH}	4.5V	$V_{OUT} = 0.1V \text{ or } V_{CC} - 0.1V$	2	2	2	V
		5.5V		2	2	2	
Maximum Low-Level Input Voltage	V_{IL}	4.5V	$V_{OUT} = 0.1V \text{ or } V_{CC} - 0.1V$	0.8	0.8	0.8	V
		5.5V		0.8	0.8	0.8	
Minimum High-Level Output Voltage	V_{OH}	4.5V	$I_{OUT} = -50\mu A$	4.4	4.4	4.4	V
		5.5V		5.4	5.4	5.4	
		4.5V	$V_{IN} = V_{IL} \text{ or } V_{IH}$ ⁵ $I_{OH} = -24mA$	3.86	3.76	3.70	V
		5.5V		4.86	4.76	4.70	

4. -55°C ≤ T_J ≤ +125°C





Advanced CMOS TTL Input – 54ACT32

Rev 1.1
08/11/2022

DC Electrical Characteristics Continued (Voltages referenced to GND)

PARAMETER	SYMBOL	V _{CC}	CONDITIONS	LIMITS			UNITS
				25°C	85°C	FULL RANGE ⁴	
Maximum Low-Level Output Voltage	V _{OL}	4.5V	I _{OUT} = 50μA	0.1	0.1	0.1	V
		5.5V		0.1	0.1	0.1	
		4.5V	V _{IN} = V _{IL} or V _{IH} ⁵ I _{OL} = 24mA	0.36	0.44	0.50	V
		5.5V		0.36	0.44	0.50	
Maximum Input Leakage Current	I _{IN}	5.5V	V _{IN} = V _{CC} or GND	±0.1	±1.0	±1.0	μA
Additional Maximum I _{CC} / Input	ΔI _{CC}	5.5V	V _{IN} = V _{CC} - 2.1V	1	1.5	1.6	mA
Minimum Dynamic Output Current ⁶	I _{OLD}	5.5V	V _{OLD} = 1.65V Max	-	75	50	mA
	I _{OHD}	5.5V	V _{OHD} = 3.85V Min	-	-75	-50	
Maximum Quiescent Supply Leakage Current	I _{CC}	5.5V	V _{IN} = V _{CC} or GND I _{OUT} = 0μA	4	40	80	μA

5. All outputs loaded; thresholds on input associated with output under test. 6. Maximum test duration 2.0 ms, one output loaded at a time.

AC Electrical Characteristics⁷ (V_{CC} = 5.0V ±0.5V)

PARAMETER	SYMBOL	V _{CC}	CONDITIONS	LIMITS			UNITS
				25°C	85°C	FULL RANGE ⁴	
Maximum Propagation Delay, Input A or B to Output Y (Figure 1)	t _{PLH}	5.0V	C _L = 50pF	9	10	12.1	ns
	t _{PHL}	5.0V		9	10	12.1	

Capacitance⁷

PARAMETER	SYMBOL	V _{CC}	CONDITIONS	TYPICAL	UNITS
Maximum Input Capacitance	C _{IN}	5.0V	T _J = 25°C	4.5	pF
Power Dissipation Capacitance	C _{PD}	5.0V	T _J = 25°C, C _L = 50pF	20	pF

7. Not production tested in die form, characterized by chip design and tested in package.





Advanced CMOS TTL Input – 54ACT32

Rev 1.1
08/11/2022

Switching Waveform

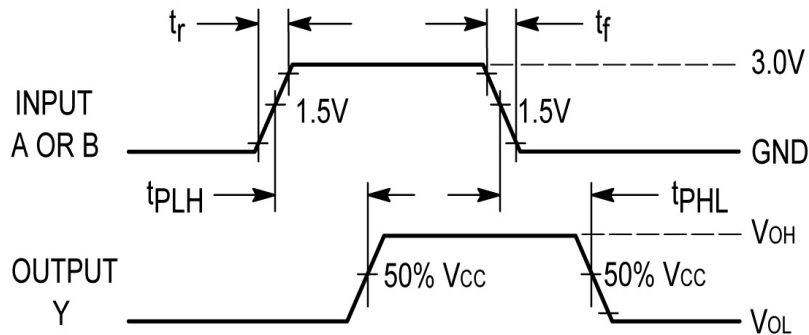
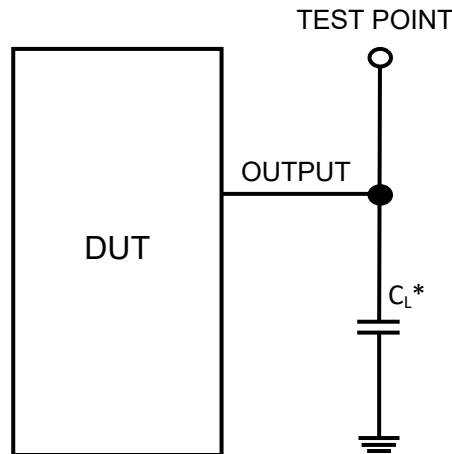

Figure 1 – Propagation Delay

Test Circuit



* Includes all probe and jig capacitance

DISCLAIMER: The information given in this document shall in no event be regarded as a guarantee of conditions or characteristics. With respect to any examples or hints given herein, any typical values stated herein and/or any information regarding the application of the device, Silicon Supplies Ltd hereby disclaims any and all warranties and liabilities of any kind.

LIFE SUPPORT POLICY: Silicon Supplies Ltd components may be used in life support devices or systems only with the express written approval of Silicon Supplies Ltd, if a failure of such components can reasonably be expected to cause the failure of that life support device or system or to affect the safety or effectiveness of that device or system. Life support devices or systems are intended to be implanted in the human body or to support and/or maintain and sustain and/or protect human life. If they fail, it is reasonable to assume that the health of the user or other persons may be endangered.

