



NPN Transistor Bare Die, 2N3904

Rev 1.0
02/09/17

General purpose amplifier or saturated switch in bare die form
Complement to PNP 2N3906

Features:

- Low Leakage Current 50nA Max
- Low Collector Output Capacitance 4pF Max
- Characterized at temperature extremes
- High Reliability Gold Back Metal
- High Reliability tested grades for Military + Space

Ordering Information:

The following part suffixes apply:

- No suffix - MIL-STD-750 /2072 Visual Inspection
- "H" - MIL-STD-750 /2072 Visual Inspection
+ MIL-PRF-38534 Class H LAT
- "K" - MIL-STD-750 /2072 Visual Inspection
+ MIL-PRF-38534 Class K LAT

LAT = Lot Acceptance Test.

For further information on LAT process flows see below.

www.siliconsupplies.com/quality/bare-die-lot-qualification

Die Dimensions in μm (mils)

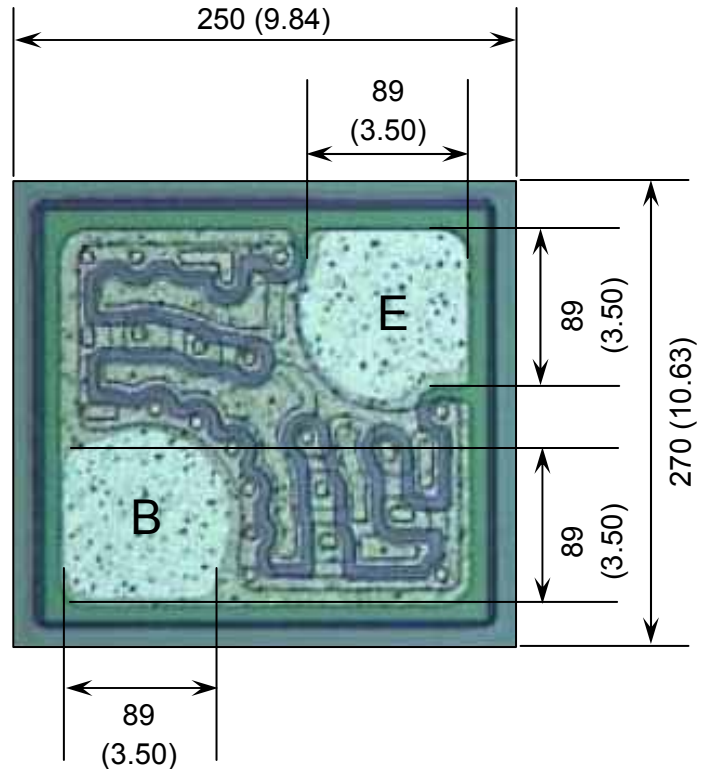

E = EMITTER **B** = BASE

DIE BACK = COLLECTOR

Supply Formats:

- Default – Die in Waffle Pack (400 per tray capacity)
- Sawn Wafer on Tape – Specific request
- Unsawn Wafer – Specific request
- With additional electrical selection – Specific request
- Sawn as pairs or adjacent pair pick – Specific request

Mechanical Specification

Die Size (Excluding Saw Street)	250 x 270 9.84 x 10.63	μm mils
Base Pad Size Emitter Pad Size	89 x 89 3.50 x 3.50	μm mils
Die Thickness	180 (± 20) 7.09 (± 0.79)	μm mils
Top Metal Composition	Al - 1.3 μm	
Back Metal Composition	AuAs - 0.9 μm	





NPN Transistor Bare Die, 2N3904

Rev 1.0
07/07/17

Absolute Maximum Ratings $T_A = 25^\circ\text{C}$ unless otherwise stated

PARAMETER	SYMBOL	VALUE	UNIT
Collector-Base Voltage	V_{CBO}	60	V
Collector-Emitter Voltage	V_{CEO}	40	V
Emitter-Base Voltage	V_{EBO}	6	V
Collector Current	I_C	200	mA
Junction Temperature	T_J	150	$^\circ\text{C}$
Storage Temperature	T_{stg}	-55 to 150	$^\circ\text{C}$

Electrical Characteristics $T_A = 25^\circ\text{C}$ unless otherwise stated

PARAMETER	SYMBOL	CONDITIONS	MIN	TYP	MAX	UNIT
OFF CHARACTERISTICS						
Collector-Base Breakdown Voltage	$V_{(BR)CBO}$	$I_C = 10\mu\text{A}$	60	-	-	V
Collector-Emitter Breakdown Voltage	$V_{(BR)CEO}$	$I_C = 1\text{mA}$	40	-	-	V
Emitter-Base Breakdown Voltage	$V_{(BR)EBO}$	$I_E = 10\mu\text{A}$	6	-	-	V
Collector Cut-off Current	I_{CEX}	$V_{CE} = 30\text{V}, V_{EB} = 3\text{V}$	-	-	50	nA
Base Cut-off Current	I_{BL}	$V_{CE} = 30\text{V}, V_{EB} = 3\text{V}$	-	-	50	nA
Emitter Cut-off Current	I_{EBO}	$V_{EB} = 5\text{V}$	-	-	50	nA
ON CHARACTERISTICS						
Forward-Current Transfer Ratio	h_{FE}	$V_{CE} = 1\text{V}, I_C = 0.1\text{mA}$	40	-	-	-
		$V_{CE} = 1\text{V}, I_C = 1\text{mA}$	70	-	-	-
		$V_{CE} = 1\text{V}, I_C = 10\text{mA}$	120	-	260	-
		$V_{CE} = 1\text{V}, I_C = 50\text{mA}$	60	-	-	-
		$V_{CE} = 1\text{V}, I_C = 100\text{mA}$	30	-	-	-
Collector-Emitter Saturation Voltage	$V_{CE(sat)}$	$I_C = 10\text{mA}, I_B = 1\text{mA}$	-	-	0.2	V
		$I_C = 50\text{mA}, I_B = 5\text{mA}$	-	-	0.3	V
Base-Emitter Saturation Voltage	$V_{BE(sat)}$	$I_C = 10\text{mA}, I_B = 1\text{mA}$	-	-	0.85	V
		$I_C = 50\text{mA}, I_B = 5\text{mA}$	-	-	0.95	V
SMALL SIGNAL CHARACTERISTICS¹						
Transition Frequency	f_T	$V_{CE} = 20\text{V}, I_E = -10\text{mA}$	300	-	-	MHz
Output Capacitance	C_{obo}	$V_{CB} = 5\text{V}, I_E = 0, f = 1\text{MHz}$	-	-	4	pF
Input Capacitance	C_{ibo}	$V_{EB} = 0.5\text{V}, I_C = 0, f = 1\text{MHz}$	-	-	8	
SWITCHING CHARACTERISTICS¹						
Delay Time	t_d	$V_{CC} = 3\text{V}, V_{BE} = 0.5\text{V}$ $I_C = 10\text{mA}, I_{B1} = 1\text{mA}$	-	-	35	ns
Rise Time	t_r		-	-	35	
Storage Time	t_s	$V_{CC} = 3\text{V}, I_C = 10\text{mA}$ $I_{B1} = I_{B2} = 1\text{mA}$	-	-	200	
Fall Time	t_f		-	-	50	

Note 1: Not production testing in die form, characterized by chip design and tested in package LAT.





NPN Transistor Bare Die, 2N3904

Rev 1.0
07/07/17

Typical Electrical Characteristics

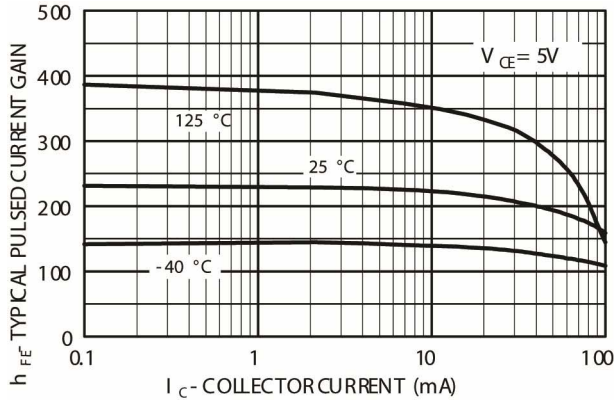

Fig 1 - Typical Pulsed Current Gain versus Collector Current

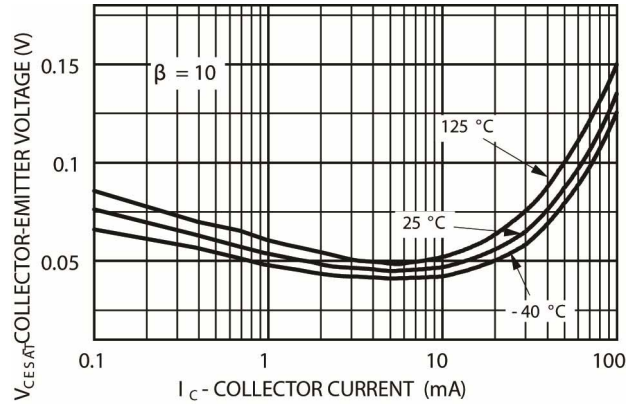

Fig 2 - Collector-Emitter Saturation Voltage versus Collector Current

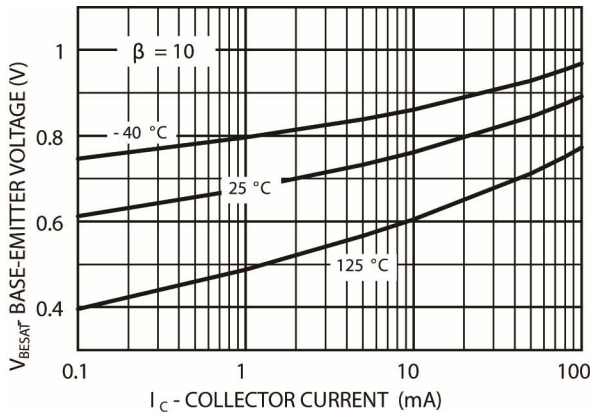

Fig 3 - Base-Emitter Saturation Voltage versus Collector Current

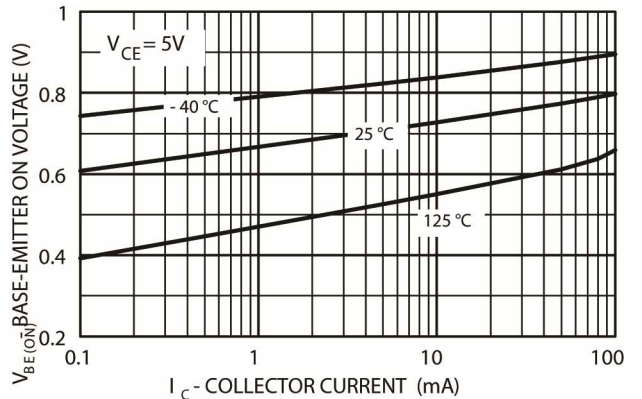

Fig 4 - Base-Emitter ON Voltage versus Collector Current

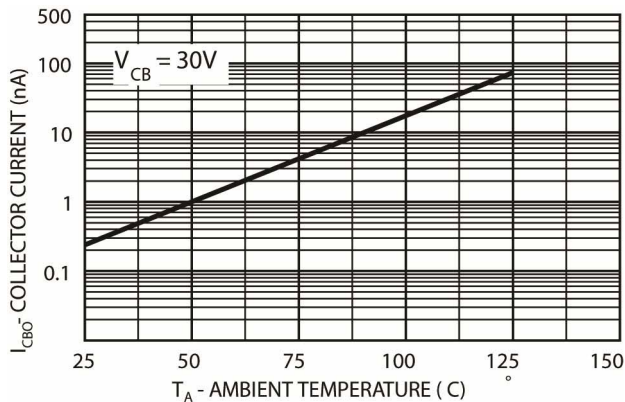

Fig 5 - Collector-Cut-off Current versus Ambient Temperature

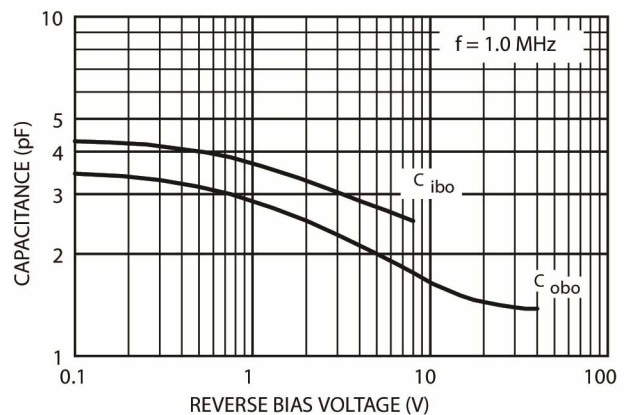

Fig 6 - Capacitance versus Reverse Bias Voltage





NPN Transistor Bare Die, 2N3904

Rev 1.0
07/07/17

Typical Electrical Characteristics (Continued)

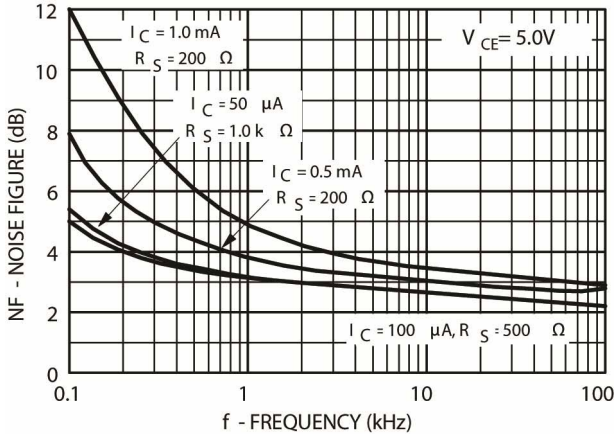

Fig 7 – Noise Figure versus Frequency

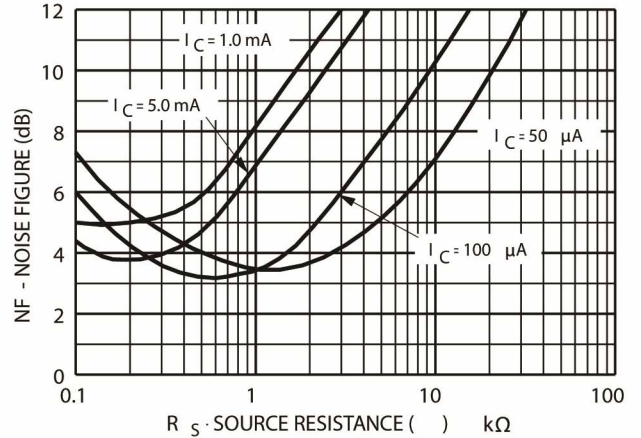

Fig 8 - Noise Figure versus Source Resistance

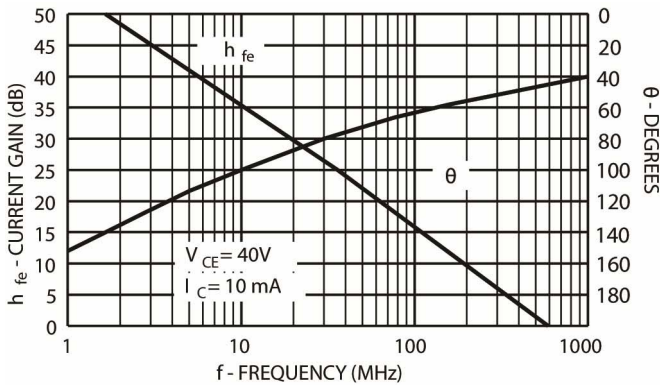

Fig 9 – Current Gain and Phase Angle versus Frequency

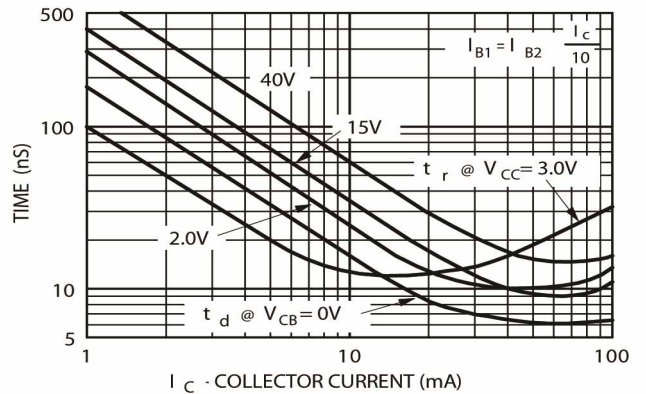

Fig 10 – Turn-On Time versus Collector Current

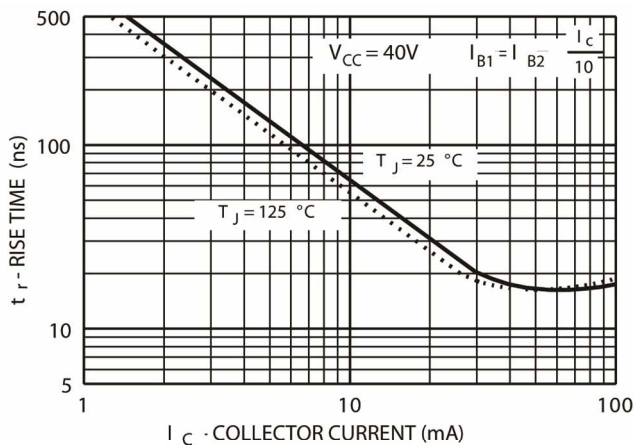

Fig 11 – Rise Time versus Collector Current

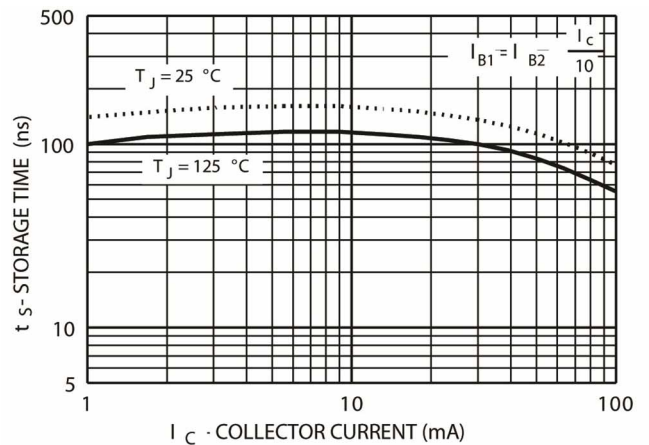

Fig 12 – Storage Time versus Collector Current





NPN Transistor Bare Die, 2N3904

Rev 1.0
07/07/17

Typical Electrical Characteristics (Continued)

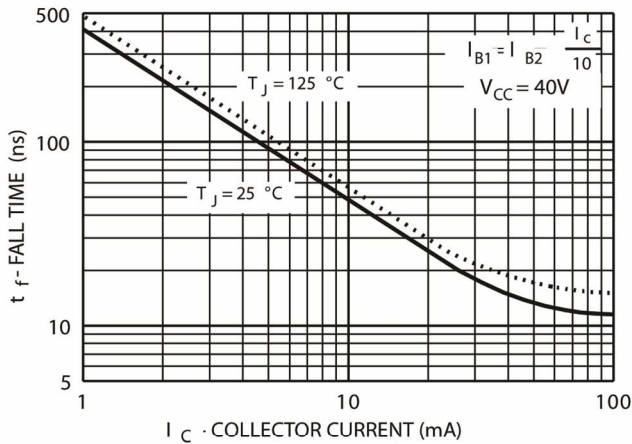

Fig 13 – Fall Time versus Collector Current

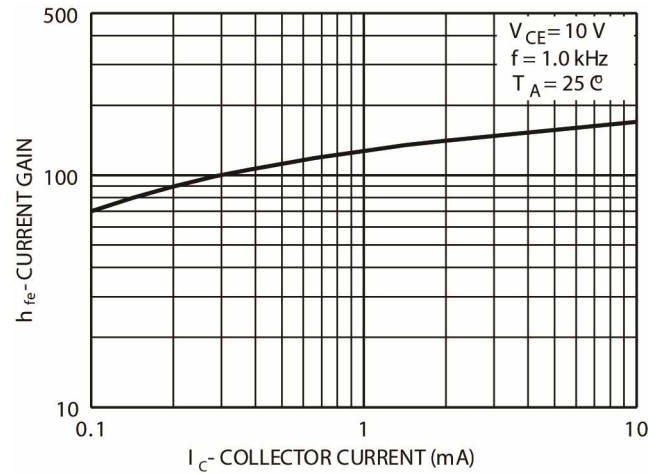

Fig 14 – Current Gain

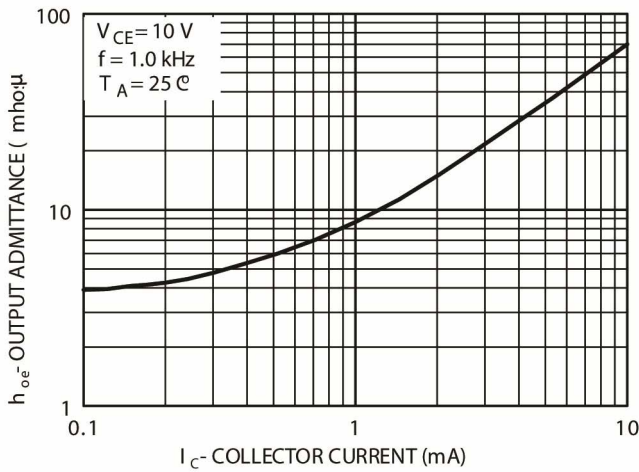

Fig 15 – Output Admittance

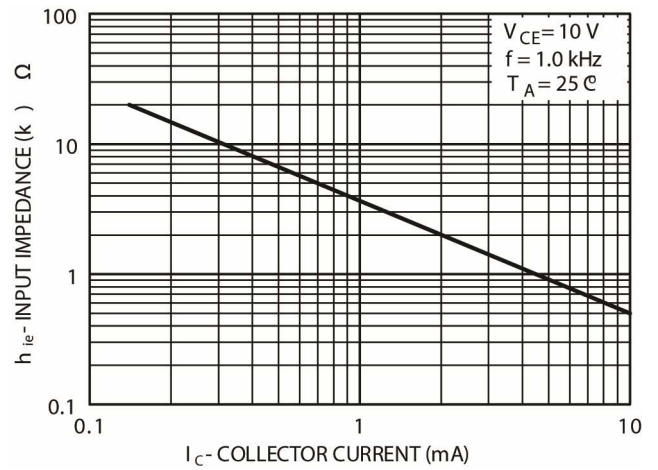

Fig 16 – Input Impedance





NPN Transistor Bare Die, 2N3904

Rev 1.0
07/07/17

Typical Electrical Characteristics (Continued)

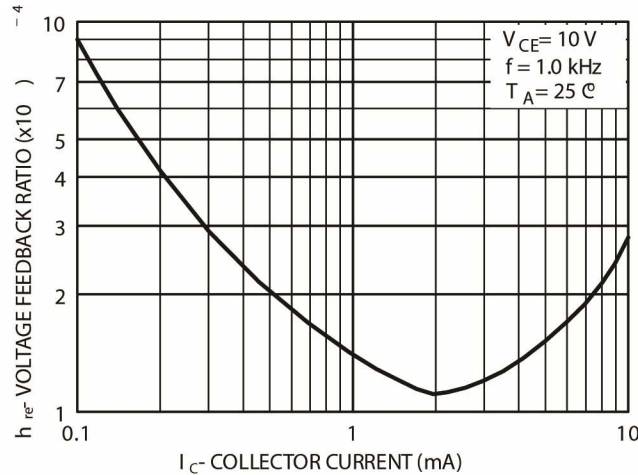

Fig 16 – Voltage Feedback Ratio

DISCLAIMER: The information given in this document shall in no event be regarded as a guarantee of conditions or characteristics. With respect to any examples or hints given herein, any typical values stated herein and/or any information regarding the application of the device, Silicon Supplies Ltd hereby disclaims any and all warranties and liabilities of any kind.

LIFE SUPPORT POLICY: Silicon Supplies Ltd components may be used in life support devices or systems only with the express written approval of Silicon Supplies Ltd, if a failure of such components can reasonably be expected to cause the failure of that life support device or system or to affect the safety or effectiveness of that device or system. Life support devices or systems are intended to be implanted in the human body or to support and/or maintain and sustain and/or protect human life. If they fail, it is reasonable to assume that the health of the user or other persons may be endangered.

