

Capacitive switch with auto-calibration, large voltage operating range and very low power consumption

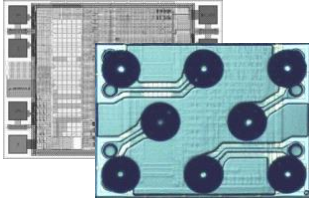

1 General Description

The integrated circuit MS8883A is a capacitive switch that uses a patented (EDISEN) digital method to detect a change in capacitance on a remote sensing plate.

Changes in the static capacitance (as opposed to dynamic capacitance changes) are automatically compensated using continuous auto-calibration. Remote sensing plates (e.g. conductive foil) can be connected remotely to the IC using coaxial cable.

2 Applications

- Hermetically sealed keys on a keyboard
- Switch for medical applications
- Switch for use in explosive environments
- Vandal proof switches
- Automotive: Switches in or under upholstery, leather, handles, mats and glass
- Portable entertainment units
- Buildings: Switch in or under carpets, glass or tiles
- Sanitary applications:
Use of standard metal sanitary parts (e.g. tap) as switch

3 Typical application

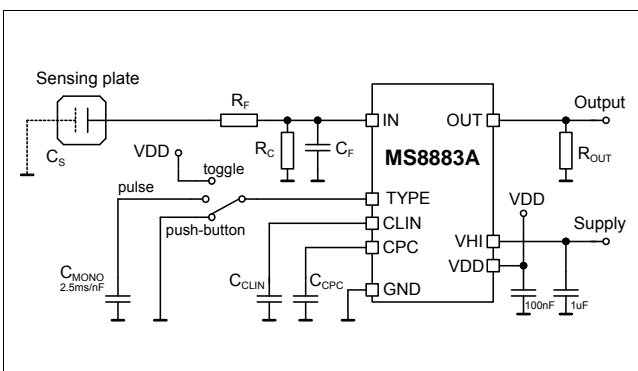

4 Features

- Dynamic proximity switch
- Digital processing method
- Automatic calibration
- Sensing plates can be connected remotely
- Open-drain output (P-type MOSFET, external load between pin and ground)
- Designed for battery powered applications (I_{HI} typ. $3\mu A$)
- Adjustable response time
- Adjustable sensitivity
- Output configurable as push-button, toggle or pulse
- Large voltage operating range ($V_{HI} = 3.0$ to $9V$)
- Large temperature operating range ($T_{amb} = -40$ to $85^{\circ}C$)
- Internal voltage regulator
- Available in SO8 package

5 Pinout

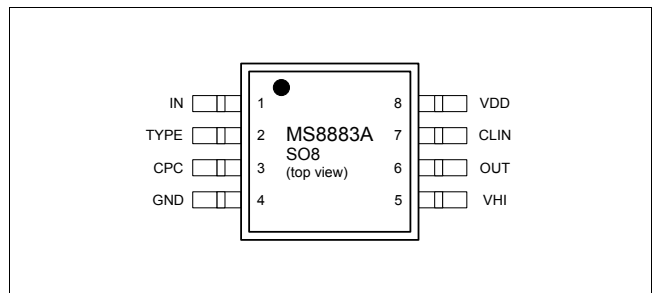

6 Ordering Information

Table 1: Ordering information

Type	Package	Shipping	Article No.
MS8883A	SO8	Tape&Reel	916683

**FOR AVAILABILITY IN BARE DIE FORM
CONTACT SALES@DIEDEVICES.COM**

7 Pin description

Table 2: Pin description

Pin	Symbol	I/O ¹	Description
1	IN	I	Sensor-Input
2	TYPE	I	Output behaviour definition
3	CPC	A	Reservoir capacitor
4	GND	S	Negative supply
5	VHI	S	Positive supply
6	OUT	O	Switch output
7	CLIN	A	Oscillator capacitor
8	VDD	S	Internal supply

8 Description

8.1 Basic functionality

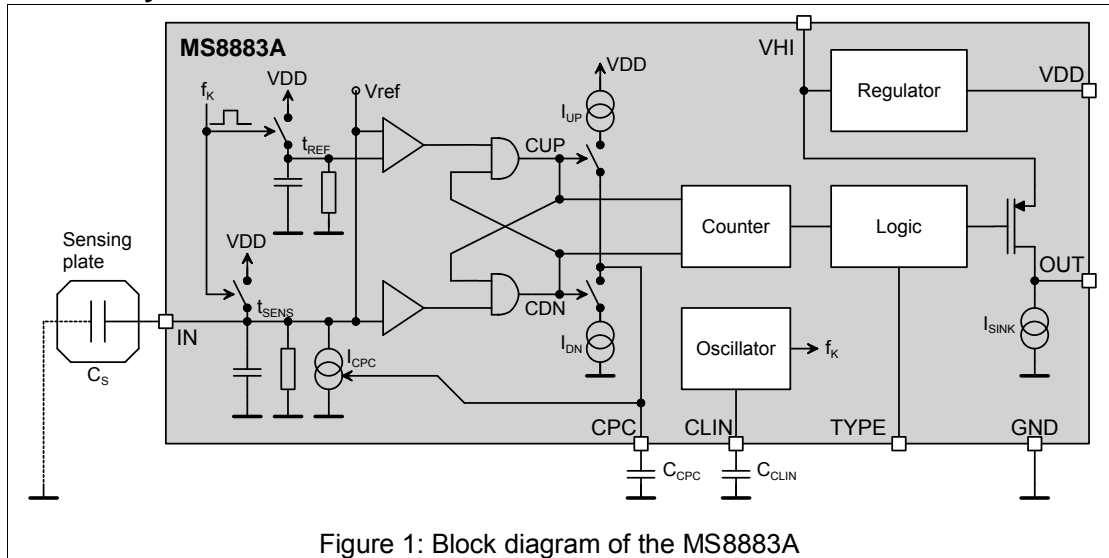

Figure 1: Block diagram of the MS8883A

Figure 1 illustrates the functional principle of the MS8883A.

The discharge time t_{SENS} on input IN attached to the sensing plate capacitance is compared to the discharge time t_{REF} of an internal RC timing element. Both RC timing circuits are periodically charged to V_{DD} via MOS switches and then discharged via a resistor to ground (GND).

The charge discharge cycle is governed by the sampling rate (f_k). When the voltage of an RC combination falls below the V_{REF} level, the appropriate comparator output will change. The logic following the comparators determines which comparator switched first. If the upper (reference) comparator switches, then a pulse is given on CUP. If the lower (input) comparator switches first then a pulse is given on CDN (see Figure 2).

The pulses control the charge on the external capacitor C_{CPC} on pin CPC. Every time a pulse is given on CUP, capacitor C_{CPC} is charged through a current source I_{UP} from V_{DD} for a fixed time causing the voltage on C_{CPC} to rise by a small increment. Likewise when a pulse occurs on CDN, capacitor C_{CPC} is discharged through a current sink I_{DN} towards ground for a fixed time, causing the voltage on C_{CPC} to fall by a small decrement.

The voltage on C_{CPC} controls an additional current sink I_{CPC} that causes the capacitance attached to the input pin IN to be discharged more quickly. This arrangement constitutes a closed-loop control system, that constantly tries to equalise the discharge time t_{SENS} with t_{REF} . In the equilibrium state, the discharge times are equal and the pulses alternate between CUP and CDN.

¹ I: Input, O: Output, S: Supply, A: Analogue

The counter following this logic counts the pulses CUP or CDN respectively. The counter is reset every time the pulse sequence changes from CUP to CDN or vice versa. The output pin OUT will only be activated when a sufficient number of consecutive CUP or CDN pulses occur. Low level interference or slow changes in the input capacitance do not cause the output to switch.

Various measures, such as asymmetrical charge and discharge steps, are taken to ensure that the output switches off correctly. A special start-up circuit ensures that the device reaches equilibrium quickly when the supply is attached.

Pin OUT is an open drain output capable of pulling an external load R_{OUT} (up to 20mA) up to V_{HI} . The load resistor must be dimensioned appropriately, taking the maximum expected V_{HI} voltage into account. The output will be automatically deactivated (short circuit protection) for loads in excess of 30mA.

A small internal 150nA current sink I_{SINK} enables a full voltage swing to take place on pin OUT, even if no load resistor is connected. This is useful for driving purely capacitive CMOS inputs. The falling slope can be fairly slow in this mode, depending on load capacitance.

The sampling rate (f_k) corresponds to half of the frequency generated in the internal sawtooth oscillator. The sampling rate can be adjusted within a specified range by selecting the value of the C_{CLIN} capacitor.

8.2 Application notes

Figure 3 shows the typical connections for a general application of the MS8883A. The positive supply (3.0V to 9.0V) is connected to pin V_{HI} . It is recommended to connect smoothing capacitors to ground to both V_{HI} and V_{DD} .

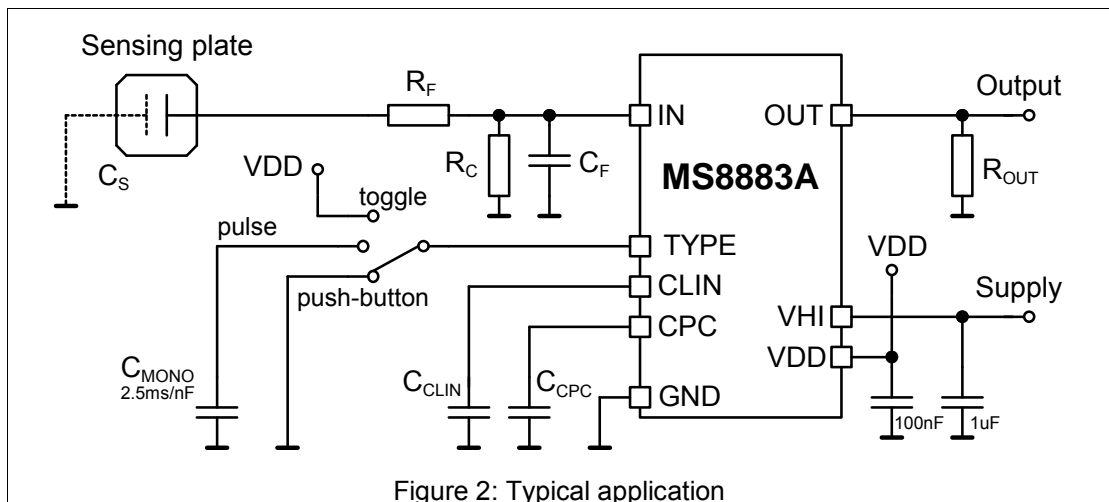

Figure 2: Typical application

The sampling rate is determined by the capacitance C_{CLIN} on pin CLIN. The rate can be adjusted from 300Hz to 3kHz. A 1kHz rate can be defined using $C_{CLIN} = 22\text{pF}$. A higher sampling rate reduces the reaction time and increases the current consumption.

The sensing plate capacitance C_S may consist of a small metal area, for example behind an isolating layer. The sensing plate is connected to a coaxial cable (C_{CABLE}) which in turn is connected to the input pin IN. An internal low pass filter is used to reduce RF interference. An additional low pass filter consisting of a resistor R_F and capacitor C_F can be added to the input to further improve RF immunity as required. Typical values are $R_F = 6.8\text{k}\Omega$ and $C_F = 10\text{pF}$. For good performance, the total amount of capacitance on the input ($C_S + C_{CABLE} + C_F$) should be in the range 10pF to 60pF, the optimum point being around 30pF. These conditions allow the control loop to adapt to the static capacitance on C_S and to compensate for slow changes in the sensing plate capacitance. A higher capacitive input loading is possible (maximum 200pF) provided that an additional discharge resistor R_C is placed as shown in Figure 2. Resistor R_C simply reduces the discharge time such that the internal timing requirements are fulfilled. A typical value for R_C is between 5 and 50k Ω .

The sensitivity of the sensor can be influenced by the sensing plate area and capacitor C_{CPC} . Typically C_{CPC} is 470nF. The sensitivity is significantly reduced when $C_{CPC} = 100\text{nF}$. Maximum sensitivity is reached when $C_{CPC} = 2.2\mu\text{F}$ but this also increases sensitivity to

interference. The CPC pin has high impedance and is sensitive to leakage currents. Therefore C_{CPC} should be a high quality foil or ceramic capacitor, for example an X7R type.

8.3 Output switching modes

The output switching behaviour can be selected using pin TYPE.

- Push-button (TYPE connected to GND): The output OUT is active as long as the capacitive event² lasts.
- Toggle (TYPE connected to VDD): The output OUT is activated by the first capacitive event and deactivated by a following capacitive event.
- Pulse (Capacitor C_{MONO} connected between TYPE and GND): The output OUT is activated for a defined time at each capacitive event. The pulse duration is determined by the value of C_{MONO} and is approximately 2.5ms/nF .

A typical value for C_{MONO} is 4.7nF which results in an output pulse duration of about 10ms . The maximum value of C_{MONO} is 470nF which results in a pulse duration of about 1s . Capacitive events that occur during the time the output is active are ignored.

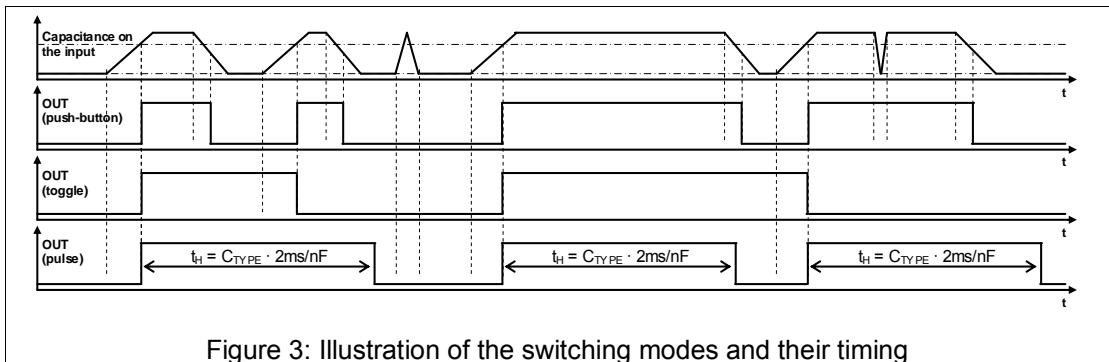
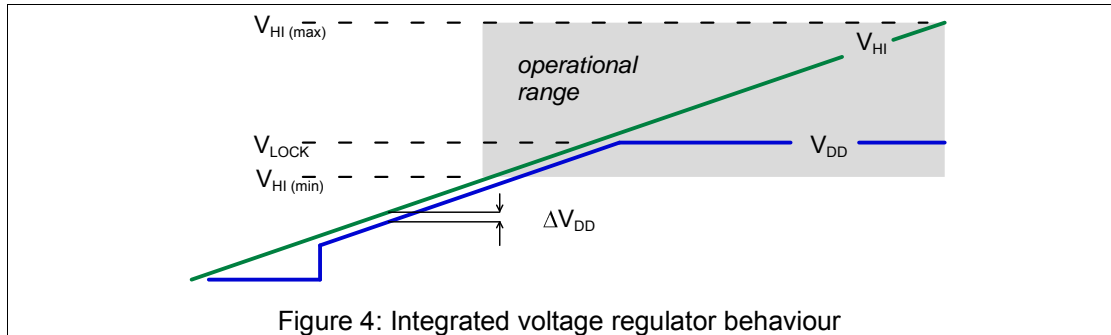

Figure 3 illustrates the switching behaviour for the three modes. Additionally the graph illustrates, that short term disturbances on the sensor are suppressed by the circuit.

² A capacitive event is a dynamic increase of capacitance at the sensor input pin IN

8.4 Internal voltage regulator

The circuit has an integrated voltage regulator, supplied by pin V_{HI} , that provides an internal V_{DD} supply, limited to a maximum of 4.6 V. The lock-in voltage, V_{LOCK} , on V_{HI} is typically 4.0 V. The regulated supply is available at pin V_{DD} and can be used to supply power to external electronic components (0.5mA maximum). Figure 4 shows the relationship between V_{HI} , V_{LOCK} and V_{DD} .



9 Electrical Characteristics

9.1 Limiting values and ESD protection

Name	Parameter	Min	Max	Unit
V_{HI}	Positive supply wrt to GND	-0.5	9.0	V
$V_{IN}, V_{TYPE}, V_{CPC}$	Input voltage on pins IN, TYPE, CPC	-0.5	$V_{DD}+0.5$	V
I_{OUT}	Output current on pins OUT to GND	-10	50	mA
I_{GND}	Total current to GND	-10	50	mA
I_{PIN}	Current through any pin	-10	10	mA
P_{TOT}	Power dissipation		100	mW
T_{stg}	Storage temperature	-60	+125	°C
V_{ESD}	electrostatic discharge voltage	HBM	+/- 2000	V
		MM	+/- 200	V

9.2 DC Characteristics

Conditions: $V_{HI} = 5V$ DC, $T = 25^{\circ}C$, if not stated otherwise

Symbol	Parameter	Conditions	Min	Typ	Max	Unit
V_{HI}	Positive supply		2.7 ³		9.0	V
V_{LOCK}	Regulator lock-in voltage	No external load		4.0		V
V_{DD}	Regulated internal supply	$V_{HI} > V_{LOCK}$	3.0	4.0	4.6	V
V_{DD}	Internal supply	VDD connected to V_{HI}	2.7 ³		4.6	V
ΔV_{DD}	Regulator voltage drop	$V_{HI} < V_{LOCK}$, no external load on V_{DD}		10	50	mV
I_{HI}	Operating current	Idle state ⁴ , output inactive, $f_k = 1$ kHz		< 3	5	μA
		Idle state ⁴ , output inactive, $f_k = 1$ kHz, $V_{HI} = 3.0V$		2.2	3.5	μA
I_{SINK}	Output sink current	Internal constant current to GND		150		nA
V_{OUT}	Output voltage	On pin OUT	0	V_{HI}	9.0	V
I_{OUT}	Output current	Operating range of output stage ⁵	0	10	20	mA
		Short circuit protection, $V_{FOUT} \geq 0.6V$	20	30	50	mA
V_{FOUT}	Output saturation voltage	on pin OUT: $I_{OUT} = 10$ mA	0.1	0.2	0.4	V
		on pin OUT: $I_{OUT} = 10$ mA, $V_{HI} = 3.0V$	0.1	0.3	0.5	V
C_{VDD}	Ext. V_{DD} decoupling capacitor	Ceramic chip capacitor recommended on pin VDD	100		220	nF
V_{CPC}	Reservoir capacitor voltage	Usable control range on pin CPC	0.6		$V_{DD}-0.3$	V
$I_{L,CPC}$	Reservoir capacitor leakage current	Low leakage X7R ceramic type recommended			1	nA
T_{amb}	Operating temperature range		-40	25	85	$^{\circ}C$

9.3 AC Characteristics

Conditions: $V_{HI} = 5V$ DC, $C_{CLIN} = 22pF$, $C_{CPC} = 470nF$, $T = 25^{\circ}C$, if not stated otherwise

Symbol	Parameter	Conditions	Min	Typ	Max	Unit
C_{CLIN}	Oscillator capacitance	Operating range	0	22	100	pF
C_{CPC}	Reservoir capacitor	Low leakage X7R ceramic type recommended	90	470	2500	nF
C_{MONO}	Pulse timing capacitor	Operating range	0.1		470	nF
		Sensing plate + parasitic	10		60	pF
C_{IN}	Input capacitance	Sensing plate + parasitic, $V_{HI}=3.0V$, full temperature range	10		40	pF
		Sensing plate + parasitic, $V_{HI}=2.7V$, over reduced temperature range $0...70^{\circ}C$	10		30	pF
t_{WAIT}	Power-on start-up time	Until idle state is established		0.5		s
t_{MONO}	Output pulse duration	On pin OUT: MONO mode selected, $C_{MONO} \geq 10nF$		2.5		ms/nF
f_k	Sampling rate	$C_{CLIN} = 0$		3.3		kHz
		$C_{CLIN} = 22$ pF		1		kHz
		$C_{CLIN} = 100$ pF		275		Hz
t_{SW}	Reaction time on sensor capacitance change	$f_k = 1$ kHz		64		ms

³ When the input capacitance range is limited to $10pF \leq C_{IN} \leq 40pF$, or an external pull down resistor R_C is used, the device can be operated down to $V_{HI}=3.0V$ over the full temperature range.

When the input capacitance range is limited to $10pF \leq C_{IN} \leq 30pF$, or an external pull down resistor R_C is used, the device can be operated down to $V_{HI}=2.7V$ over the reduced temperature range $0 \dots 70^{\circ}C$.

⁴ Idle state is the steady state after completed power-up, without any activity on the sensor plate, and the voltage on the reservoir capacitor C_{CPC} settled.

⁵ For reliability reasons the average output current must be limited to maximum $4.6mA@70^{\circ}C$ and $3.0mA@85^{\circ}C$

10 Package outlines

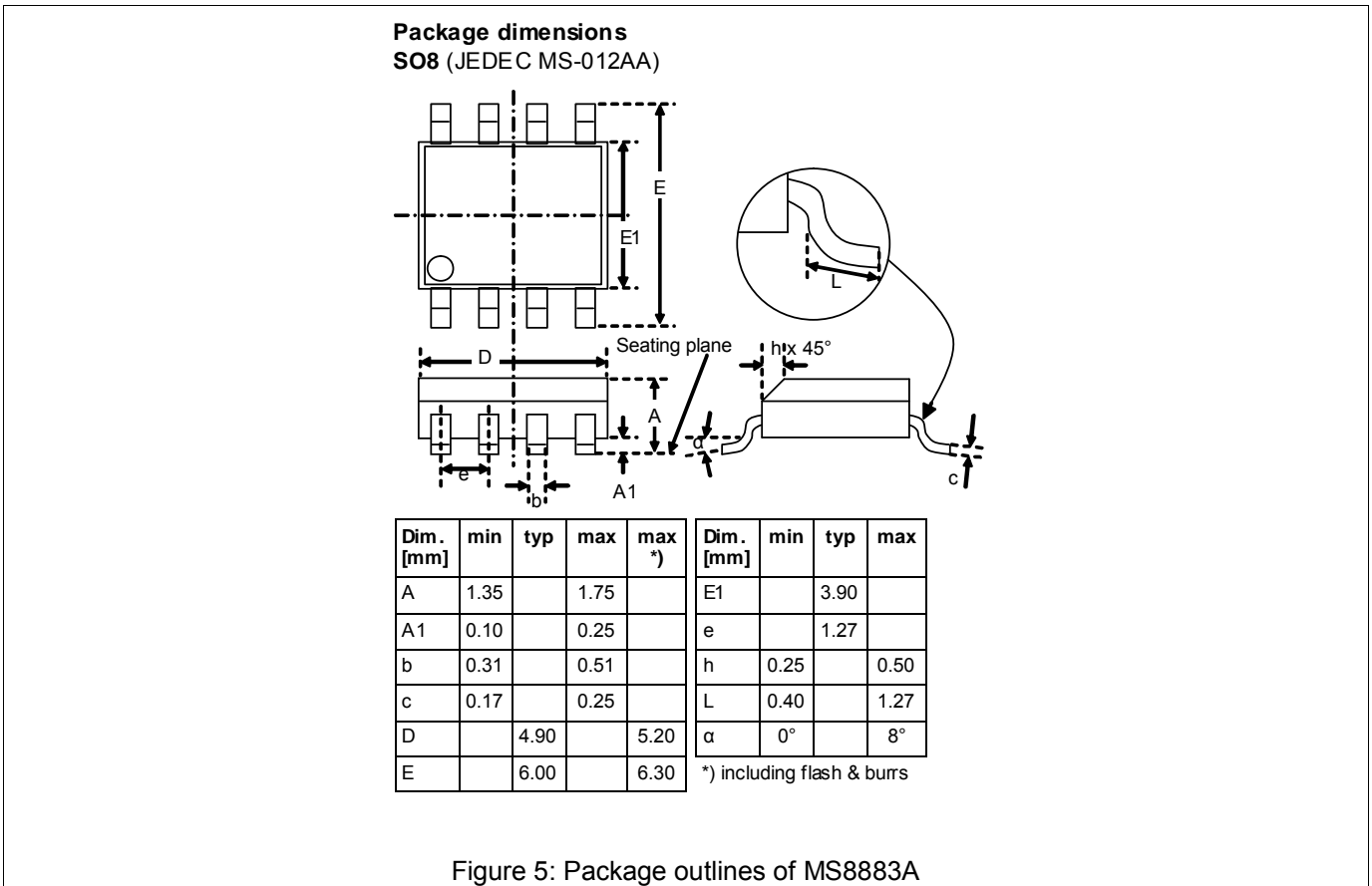

Figure 5: Package outlines of MS8883A

11 Legal disclaimer

This product is not designed for use in life support appliances or systems where malfunction of these parts can reasonably be expected to result in personal injury. Customers using or selling this product for use in such appliances do so at their own risk and agree to fully indemnify Microdul AG for any damages resulting from such applications.

12 Contents

1	General Description	1
2	Applications	1
3	Typical application	1
4	Features.....	1
5	Pinout.....	1
6	Ordering Information.....	1
7	Pin description	2
8	Description	2
8.1	Basic functionality.....	2
8.2	Application notes	3
8.3	Output switching modes	4
8.4	Internal voltage regulator.....	5
9	Electrical Characteristics	5
9.1	Limiting values and ESD protection	5
9.2	DC Characteristics	6

9.3	AC Characteristics	6
10	Package outlines	7
11	Legal disclaimer.....	7
12	Contents	7