

# LINEAR SYSTEMS

Twenty-Five Years Of Quality Through Innovation

## U421, U422, U423, U424, U425, U426

LOW LEAKAGE LOW DRIFT  
MONOLITHIC DUAL N-CHANNEL  
JFET AMPLIFIER

FEATURES	
HIGH INPUT IMPEDANCE	$I_G=0.25\text{pA MAX}$
HIGH GAIN	$g_{fs}=120\mu\text{S MIN}$
LOW POWER OPERATION	$V_{GS(off)}=2\text{V MAX}$
ABSOLUTE MAXIMUM RATINGS NOTE 1	
@ 25 °C (unless otherwise noted)	
Maximum Temperatures	
Storage Temperature	-55 to +150°C
Operating Junction Temperature	-55 to +150°C
Maximum Voltage and Current for Each Transistor NOTE 1	
$-V_{GSS}$	Gate Voltage to Drain or Source 40V
$-V_{DSO}$	Drain to Source Voltage 40V
$I_{G(f)}$	Gate Forward Current 10mA
Maximum Power Dissipation	
Total Device Dissipation $T_A = 25^\circ\text{C}$	500 <sup>2</sup> mW

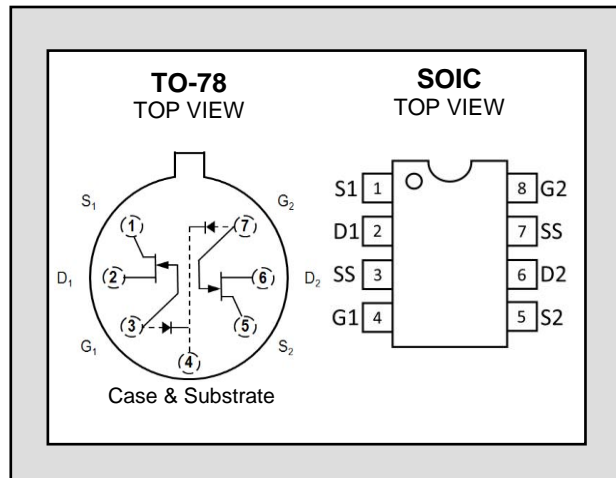

### ELECTRICAL CHARACTERISTICS @ 25°C (unless otherwise noted)

SYMBOL	CHARACTERISTIC <sup>3</sup>	U421	U422	U423	U424	U425	U426	UNITS	CONDITIONS	
$ \Delta V_{GS1-2}/\Delta T $ max.	Drift vs. Temperature	10	25	40	10	25	40	$\mu\text{V}/^\circ\text{C}$	$V_{DG} = 10\text{V}$ $I_D = 30\mu\text{A}$ $T_A = -55^\circ\text{C}$ to $+125^\circ\text{C}$	
$ V_{GS1-2} $ max.	Offset Voltage	10	15	25	10	15	25	mV	$V_{DG} = 10\text{V}$ $I_D = 30\mu\text{A}$	
$V_{GS(off)}$	<b>GATE VOLTAGE</b>									
	Pinchoff Voltage	Max	-2.0	-2.0	-2.0	-3.0	-3.0	-3.0	V	$V_{DS}=10\text{V}$ $I_D=1\text{nA}$
		Min	-0.4	-0.4	-0.4	-0.4	-0.4	-0.4		
$V_{GS}$	Operating Range	Max	-1.8	-1.8	-1.8	-2.9	-2.9	-2.9	V	$V_{DS}=10\text{V}$ $I_D=30\mu\text{A}$
$I_{GTYP.}$	Operating		-0.25	-0.25	-0.25	-0.500	-0.500	-0.500	pA	$V_{DS}=10\text{V}$ $I_D=30\mu\text{A}$
$I_{GTYP.}$	High Temperature		-250	-250	-250	-500	-500	-500	pA	$T_A=+125^\circ\text{C}$
$I_{GSSTYP.}$	Gate Reverse Current		-1.0	-1.0	-1.0	-3.0	-3.0	-3.0	pA	$V_{DS}=0\text{V}$ $V_{GS}=-20\text{V}$
$I_{GSSTYP.}$	Gate Reverse Current		1.0	1.0	1.0	3.0	3.0	3.0	nA	$T_A=+125^\circ\text{C}$

SYMBOL	CHARACTERISTIC	MIN.	TYP.	MAX.	UNITS	CONDITIONS
$BV_{GSS}$	Breakdown Voltage	-40	-60	--	V	$V_{DS}=0\text{V}$ $I_G = -1\text{nA}$
$BV_{GGO}$	Gate-to-Gate Breakdown	$\pm 40$	--	--	V	$I_{G1G2} = \pm 1\mu\text{A}$ $I_D = 0\text{A}$ $I_S = 0\text{A}$
$g_{fs}$	<b>TRANSCONDUCTANCE</b>					
	Full Conduction	300	--	1500	$\mu\text{S}$	$V_{DS}=10\text{V}$ $V_{GS}=0$ $f=1\text{kHz}$
$g_{fs}$	Typical Operation	120	200	350	$\mu\text{S}$	$V_{DG}=10\text{V}$ $I_D=30\mu\text{A}$ $f=1\text{kHz}$
$I_{DSS}$	<b>DRAIN CURRENT</b>					
	Full Conduction	60	--	1000	$\mu\text{A}$	U421-3 $V_{DS}=10\text{V}$ $V_{GS}=0$
		60	--	1800	$\mu\text{A}$	U424-6

SYMBOL	CHARACTERISTIC	MIN.	TYP.	MAX.	UNITS	CONDITIONS
<b>OUTPUT CONDUCTANCE</b>						
g <sub>os</sub>	Full Conduction	--	--	10	μS	V <sub>DS</sub> = 10V V <sub>GS</sub> = 0
g <sub>os</sub>	Operating	--	0.1	3.0	μS	V <sub>DG</sub> = 10V I <sub>D</sub> = 30μA
<b>COMMON MODE REJECTION</b>						
CMRR	$-20 \log  V_{GS1-2}/\Delta V_{DS} $	--	90	--	dB	$\Delta V_{DS}$ = 10 to 20V I <sub>D</sub> =30μA
CMRR	$-20 \log  V_{GS1-2}/\Delta V_{DS} $	--	90	--	dB	$\Delta V_{DS}$ = 5 to 10V I <sub>D</sub> =30μA
<b>NOISE</b>						
NF	Figure	--	--	1.0	dB	V <sub>DG</sub> = 10V, I <sub>D</sub> = 30μA, R <sub>G</sub> =10MΩ f= 10Hz
e <sub>n</sub>	Voltage	--	20	70	nV/√Hz	V <sub>DG</sub> = 10V I <sub>D</sub> = 30μA f= 10Hz
		--	10	--	--	V <sub>DG</sub> = 10V I <sub>D</sub> = 30μA f= 1kHz
<b>CAPACITANCE</b>						
C <sub>ISS</sub>	Input	--	--	3.0	pF	V <sub>DS</sub> = 10V V <sub>GS</sub> = 0 f= 1MHz
C <sub>RSS</sub>	Reverse Transfer	--	--	1.5	pF	V <sub>DS</sub> = 10V V <sub>GS</sub> = 0 f= 1MHz

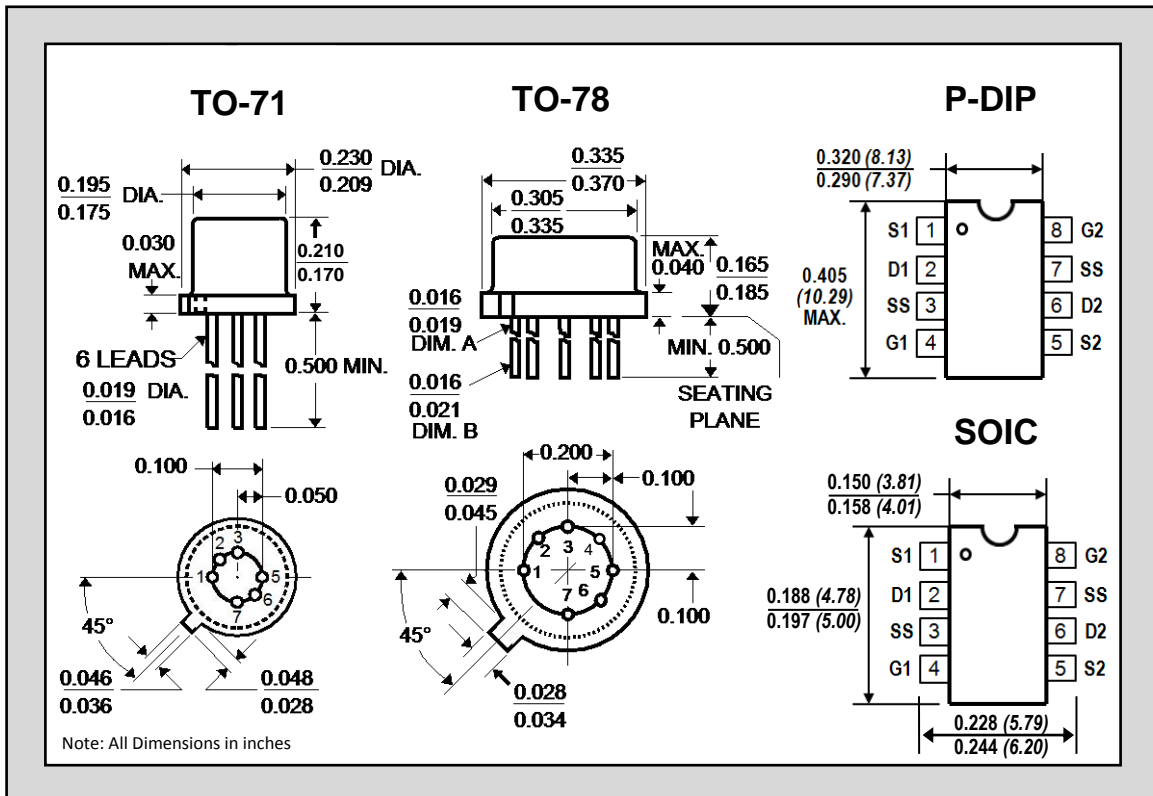

### NOTES:

1. These ratings are limiting values above which the serviceability of any semiconductor may be impaired
2. Derate 4mW/°C above 25°C
3. All MIN/TYP/MAX limits are absolute numbers. Negative signs indicate electrical polarity only.

Information furnished by Linear Integrated Systems is believed to be accurate and reliable. However, no responsibility is assumed for its use; nor for any infringement of patents or other rights of third parties which may result from its use. No license is granted by implication or otherwise under any patent or patent rights of Linear Integrated Systems.

Linear Integrated Systems (LIS) is a 25-year-old, third-generation precision semiconductor company providing high-quality discrete components. Expertise brought to LIS is based on processes and products developed at Amelco, Union Carbide, Intersil and Micro Power Systems by company President John H. Hall. Hall, a protégé of Silicon Valley legend Dr. Jean Hoerni, was the director of IC Development at Union Carbide, Co-Founder and Vice President of R&D at Intersil, and Founder/President of Micro Power Systems.