



Linear Voltage Regulator - SiS1084L-3.3

Positive Fixed 3.3V Output Low Dropout Voltage Regulator in bare die form

Rev 1.0
10/05/22

Description

The SiS1084L-3.3V is a positive 3.3V fixed output regulator providing 5A output current with high efficiency. The device accepts input voltages up to 12V and is optimised for smallest die size. Voltage dropout is guaranteed at 1.5V maximum at 5A. This device also features on-chip trimming for current limit + output voltage and includes thermal shutdown for rugged performance.

Features:

- 12V input capability with optimised die size
- 1.5V dropout voltage maximum at 5A
- Internal current limiting & reference trimming
- Thermal shutdown
- Line & Load Regulation: 20mV maximum
- Full military temperature range.

Ordering Information

The following part suffixes apply:

- No suffix - MIL-STD-883 /2010B Visual Inspection
- "H" - MIL-STD-883 /2010B Visual Inspection + MIL-PRF-38534 Class H LAT
- "K" - MIL-STD-883 /2010A Visual Inspection (Space) + MIL-PRF-38534 Class K LAT

LAT = Lot Acceptance Test.

For further information on LAT process flows see below.

www.siliconsupplies.com/quality/bare-die-lot-qualification

Die Dimensions in μm (mils)

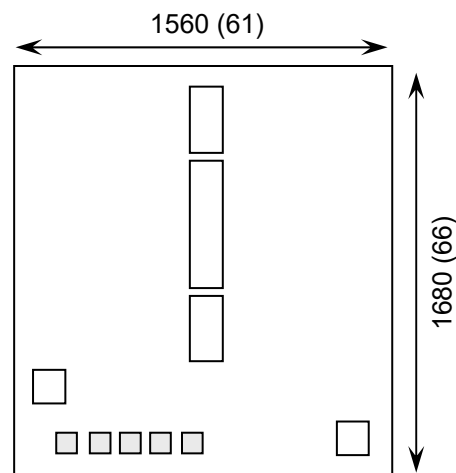

Supply Formats:

- Default - Die in Waffle Pack (100 per tray capacity)
- Sawn Wafer on Tape – On request
- Un-sawn Wafer – On request
- In Metal or Ceramic package – On request

Mechanical Specification

Die Size (Unsawn)	1560 x 1680 61 x 66	μm mils
Minimum Bond Pad Size	130 x 130 5.11 x 5.11	μm mils
Die Thickness	350 (± 20) 13.78 (± 0.79)	μm mils
Top Metal Composition	Al 1%Si 1.4 μm	
Back Metal Composition	Ti/Ni/Ag	





Linear Voltage Regulator - SiS1084L-3.3

Rev 1.0

10/05/22

Pad Layout and Functions

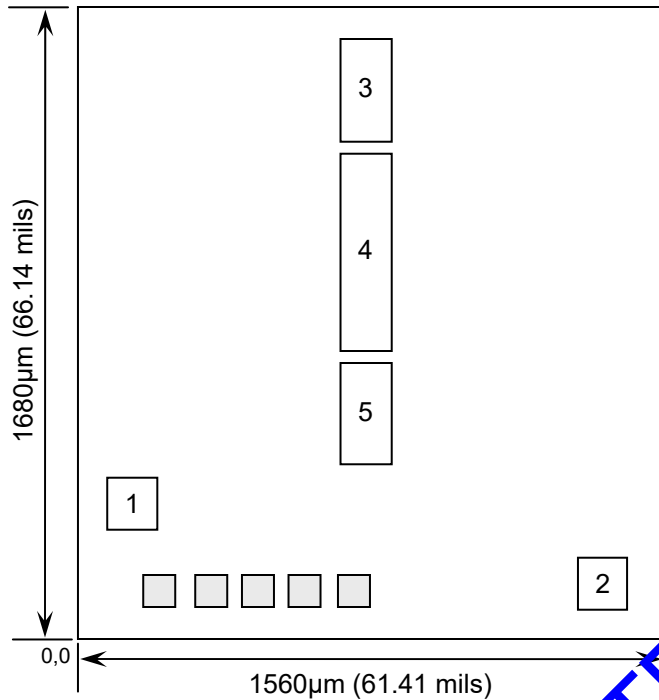

PAD	FUNCTION	COORDINATES (µm)	
		X	Y
1	OUTPUT	80	296
2	GND	1016	80
3	INPUT	713	1331
4	OUTPUT	713	771
5	INPUT	713	471
CONNECT CHIP BACK TO OUTPUT			

Typical Application

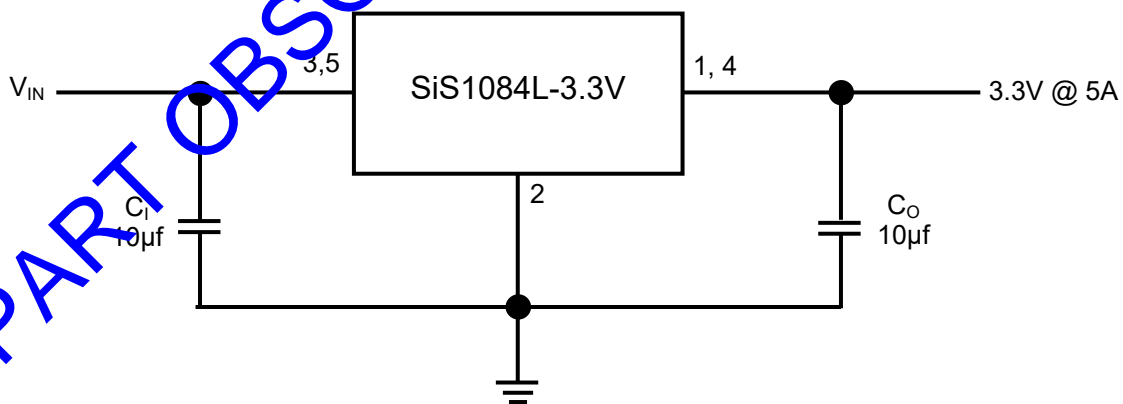

Application Notes:

C_1 is required if the regulator is located an appreciable distance from power supply filter. C_0 is not required for stability; however it does improve transient response. For optimum stability and transient response locate C_1 , C_0 as close as possible to the regulator.

The device can operate with up to 12V input voltage supply. This input supply must be well regulated. Additional low ESR input capacitance improves the output noise performance if the input supply is noisy.





Linear Voltage Regulator - SiS1084L-3.3

Rev 1.0

10/05/22

Absolute Maximum Ratings¹ $T_J = 25^\circ\text{C}$ unless otherwise stated

PARAMETER	SYMBOL	VALUE	UNIT
Input-to-Output Voltage Differential	V_{DIFF}	12	V
Power Dissipation ²	P_D	Internally limited	mW
Operating Temperature Range	T_J	-55 to 150	°C
Storage Temperature	T_{STG}	-65 to 150	°C

Recommended Operating Conditions $T_J = 25^\circ\text{C}$ unless otherwise stated

PARAMETER	SYMBOL	MIN	MAX	UNIT
Input Voltage	V_{IN}	0	2	V
Output Current	I_{OUT}		5	A
Operating Temperature Range	T_J	-55	+125	°C

DC Electrical Characteristics $T_J = 25^\circ\text{C}$ unless otherwise specified

PARAMETER	SYMBOL	TEST CONDITIONS	MIN	TYP	MAX	UNITS	
Reference Voltage	V_{OUT}	$I_{\text{OUT}} = 10\text{mA}$, $V_{\text{IN}} = 6.3\text{V}$		3.270	3.300	3.330	V
		$0 \leq I_{\text{OUT}} \leq I_{\text{FULL LOAD}}$, $4.8\text{V} \leq V_{\text{IN}} \leq 10\text{V}$	$T_J = 25^\circ\text{C}$	3.250	3.300	3.350	
			Full range ³	3.235	3.300	3.365	
Line Regulation	ΔV_{OUT}	$I_{\text{OUT}} = 10\text{mA}$, $4.8\text{V} \leq V_{\text{IN}} \leq 10\text{V}$	$T_J = 25^\circ\text{C}$	-	-	6	mV
			Full range ³	-	-	10	
Load Regulation	ΔV_{OUT}	$V_{\text{IN}} = 5.0\text{V}$, $0 \leq I_{\text{OUT}} \leq I_{\text{FULL LOAD}}$	$T_J = 25^\circ\text{C}$	-	-	15	mV
			Full range ³	-	-	20	
Dropout Voltage	$V_{\text{IN}} - V_{\text{OUT}}$	$\Delta V_{\text{REF}}, \Delta V_{\text{OUT}} = 1\%$, $I_{\text{OUT}} = 5\text{A}$	Full range ³	-	1.3	1.5	V
Minimum Load Current	I_{L}	$V_{\text{IN}} = 10\text{V}$	Full range ³	-	5	10	mA
Output Current Limit	I_{LIMIT}	$V_{\text{IN}} = 6.25\text{V}$	Full range ³	5.5	-	-	A
Ripple Rejection	RR	$I_{\text{OUT}} = 5\text{A}$; $V_{\text{IN}} = 4.25\text{V}$, $f_{\text{RIPPLE}} = 120\text{Hz}$, $C_{\text{OUT}} = 25\mu\text{F}$	Full range ³	60	-	-	dB
Temperature Stability	-		Full range ³	-	0.5	-	%

1. Operation above the absolute maximum rating may cause device failure. Operation at the absolute maximum ratings, for extended periods, may reduce device reliability. 2. Results in die form are dependent on die attach and assembly method 3. $-55^\circ\text{C} \leq T_J \leq 125^\circ\text{C}$





Linear Voltage Regulator - SiS1084L-3.3

Rev 1.0
10/05/22

**** PART OBSOLETE ** - DISCONTINUED**

DISCLAIMER: The information given in this document shall in no event be regarded as a guarantee of conditions or characteristics. With respect to any examples or hints given herein, any typical values stated herein and/or any information regarding the application of the device, Silicon Supplies Ltd hereby disclaims any and all warranties and liabilities of any kind.

LIFE SUPPORT POLICY: Silicon Supplies Ltd components may be used in life support devices or systems only with the express written approval of Silicon Supplies Ltd, if a failure of such components can reasonably be expected to cause the failure of that life support device or system or to affect the safety or effectiveness of that device or system. Life support devices or systems are intended to be implanted in the human body or to support and/or maintain and sustain and/or protect human life. If they fail, it is reasonable to assume that the health of the user or other persons may be endangered.

