



# Linear Voltage Regulator – LM317

Positive Adjustable 1.5A output Voltage Regulator in bare die form

Rev 1.0  
03/03/18

## Description

The LM317 is a wide  $V_{IN}$  adjustable 3-terminal voltage regulator with guaranteed 1.5A output current and equipped with internal limiting + thermal shutdown features for overload immunity. Output voltage is set by two external resistors. Additional to standard regulator function, the device can be used as a simple adjustable switching regulator; a programmable output regulator; or by connecting a fixed resistor between adjustment pin and output, can be used as a precision current regulator. A shutdown mechanism can be introduced by clamping the adjust terminal to ground which programs output to 1.2V where most loads draw little current.

## Features:

- Output current in excess of 1.5A
- Adjustable output between 1.2V – 37V
- Internal short circuit current limit
- Internal thermal overload protection
- Output transistor Safe-Area Compensation
- Floating operation for high voltage applications
- 0.01% Line & 0.1% Load Regulation
- Negative Voltage complement is LM337

## Ordering Information

The following part suffixes apply:

- No suffix - MIL-STD-883 /2010B Visual Inspection
- "H" - MIL-STD-883 /2010B Visual Inspection + MIL-PRF-38534 Class H LAT
- "K" - MIL-STD-883 /2010A Visual Inspection (Space) + MIL-PRF-38534 Class K LAT

LAT = Lot Acceptance Test.

For further information on LAT process flows see below.

[www.siliconsupplies.com/quality/bare-die-lot-qualification](http://www.siliconsupplies.com/quality/bare-die-lot-qualification)

## Die Dimensions in $\mu\text{m}$ (mils)

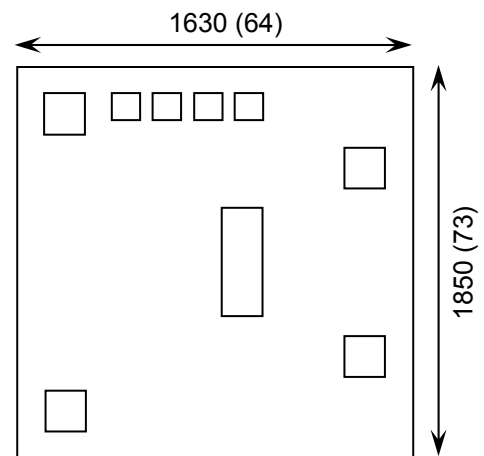

## Supply Formats:

- Default – Die in Waffle Pack (100 per tray capacity)
- Sawn Wafer on Tape – On request
- Unsawn Wafer – On request
- Tape & Reel – On request
- In Metal or Ceramic package – On request

## Mechanical Specification

Die Size (Unsawn)	1630 x 1850 64 x 73	$\mu\text{m}$ mils
Minimum Bond Pad Size	140 x 140 5.51 x 5.51	$\mu\text{m}$ mils
Die Thickness	350 ( $\pm 20$ ) 13.78 ( $\pm 0.79$ )	$\mu\text{m}$ mils
Top Metal Composition	Al 1%Si 2.2 $\mu\text{m}$	
Back Metal Composition	Ti/Ni/Ag 1.2 $\mu\text{m}$	





# Linear Voltage Regulator – LM317

Rev 1.0  
03/03/18

## Pad Layout and Functions

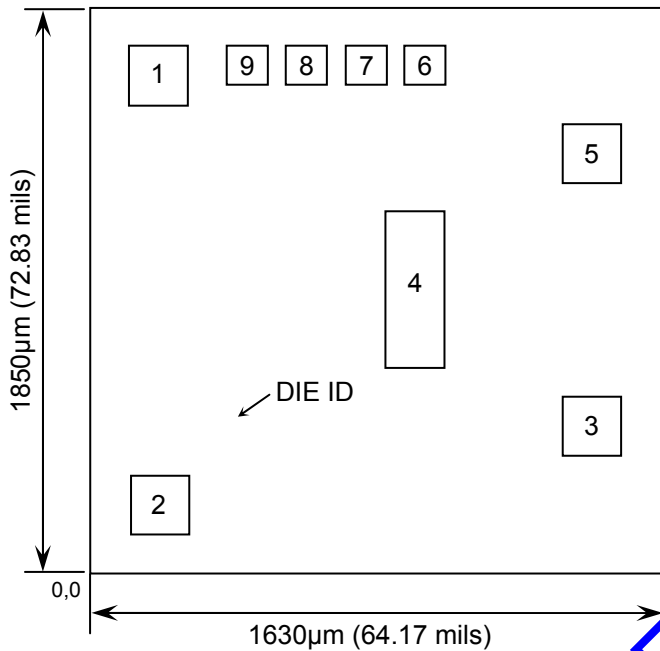

PAD	FUNCTION	COORDINATES (mm)	
		X	Y
1	V <sub>OUT</sub>	0.073	1.637
2	ADJ	0.073	0.073
3	V <sub>OUT</sub>	1.400	0.331
4	V <sub>IN</sub> (X2 wire)	0.773	0.714
5	V <sub>OUT</sub>	1.400	1.402
6	NC	0.641	1.715
7	NC	0.512	1.715
8	NC	0.383	1.715
9	NC	0.254	1.715

NC = NO CONNECT  
CONNECT CHIP BACK TO V<sub>OUT</sub>

## Typical Application

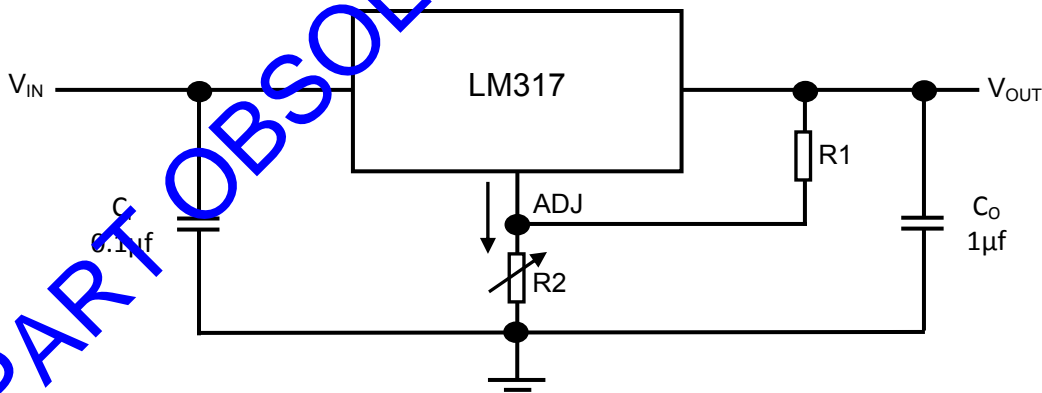

1.2V–25V Adjustable Regulator

$$V_{OUT} = 1.25V \left(1 + \frac{R_2}{R_1}\right) + I_{ADJ} * R_2$$

I<sub>ADJ</sub> tolerance <100µA

C<sub>1</sub> is required if the regulator is located an appreciable distance from power supply filter. C<sub>0</sub> is not required for stability; however it does improve transient response. For optimum stability and transient response locate C<sub>1</sub> C<sub>0</sub> as close as possible to the regulator.





# Linear Voltage Regulator – LM317

Rev 1.0  
03/03/18

## Absolute Maximum Ratings<sup>1</sup>

PARAMETER	SYMBOL	VALUE	UNIT
Input–Output Voltage differential	$V_{IN} - V_{OUT}$	40	V
Power Dissipation	$P_D$	Internally Limited	
Operating Junction Temperature	$T_J$	150	°C
Storage Temperature	$T_{STG}$	-65 to 150	°C

## Recommended Operating Conditions

PARAMETER	SYMBOL	MIN	MAX	UNIT
Output Voltage	$V_{OUT}$	1.25	37	V
Input–Output Voltage differential	$V_{IN} - V_{OUT}$	4	40	V
Output Current	$I_{OUT}$	0.01	1.5	A
Operating Junction Temperature Range	$T_J$	0 to 125		°C

## DC Electrical Characteristics, $V_{IN} - V_{OUT} = 5V$ , $I_{OUT} = 0.5A$ , $I_{MAX} = 1.5A$ , $T_J = 0^\circ C$ to $+125^\circ C$ (unless noted otherwise)

PARAMETER	SYMBOL	TEST CONDITIONS	MIN	TYP	MAX	UNITS
Reference Voltage	$V_{REF}$	$3V \leq  V_{IN} - V_{OUT}  \leq 40V$ , $10mA \leq I_{OUT} \leq I_{MAX}$	1.2	1.25	1.30	V
Line Regulation <sup>2</sup>	$\Delta V_{OUT}$	$3V \leq  V_{IN} - V_{OUT}  \leq 40V$ , $T_J = 25^\circ C$	-	0.01	0.04	% / $V_{OUT}$
		$3V \leq  V_{IN} - V_{OUT}  \leq 40V$	-	0.02	0.07	
Load Regulation <sup>2</sup>	$\Delta V_{OUT}$	$V_{IN} \leq 5V$ , $10mA \leq I_{OUT} \leq I_{MAX}$ , $T_J = 25^\circ C$	-	5	25	mV
		$V_{IN} \geq 3V$ , $10mA \leq I_{OUT} \leq I_{MAX}$ , $T_J = 25^\circ C$	-	0.1	0.5	% / $V_{OUT}$
		$V_{IN} \leq 5V$ , $10mA \leq I_{OUT} \leq I_{MAX}$	-	20	70	mV
		$V_{IN} \geq 5V$ , $10mA \leq I_{OUT} \leq I_{MAX}$	-	0.3	1.5	% / $V_{OUT}$
Thermal Regulation		20ms pulse, $T_J = 25^\circ C$	-	0.03	0.07	% / W
Adjustment Pin Current	$I_{ADJ}$		-	50	100	$\mu A$
Adjustment Pin Current Change	$\Delta I_{ADJ}$	$2.5V \leq  V_{IN} - V_{OUT}  \leq 40V$ , $10mA \leq I_L \leq I_{MAX}$ , $P_D \leq P_{MAX}$	-	0.2	5.0	$\mu A$
Temperature Stability	-	$T_{LOW} \leq T_J \leq T_{HIGH}$	-	1	-	%
Minimum Load Current	$I_L$	$ V_{IN} - V_{OUT}  = 40V$	-	3.5	10	mA
Output Current Limit <sup>3</sup>	$I_{MAX}$	$ V_{IN} - V_{OUT}  \leq 15V$ , $P \leq 20W$	1.5	2.2	-	A
		$ V_{IN} - V_{OUT}  = 40V$ , $P \leq 20W$ , $T_J = 25^\circ C$	0.15	0.40	-	

1. Operation above the absolute maximum rating may cause device failure. Operation at the absolute maximum ratings, for extended periods, may reduce device reliability.

2. Regulation is measured at a constant junction temperature, using pulse testing with a low duty cycle. Changes in output voltage due to heating effects are covered under the specifications for thermal regulation.





# Linear Voltage Regulator – LM317

Rev 1.0

03/03/18

DC Electrical Characteristics,  $V_{IN} - V_{OUT} = 5V$ ,  $I_{OUT} = 0.5A$ ,  $I_{MAX} = 1.5A$ ,  $T_J = 0^\circ C$  to  $+125^\circ C$  (unless noted otherwise)

PARAMETER	SYMBOL	TEST CONDITIONS	MIN	TYP	MAX	UNITS
RMS Output Noise, % of $V_{OUT}$	eN	$10\text{ Hz} \leq f \leq 10\text{ kHz}$ , $T_J = 25^\circ C$	-	0.003	-	%
Ripple Rejection Ratio	RR	$V_{OUT} = 10V$ , $f = 120\text{ Hz}$ , $C_{ADJ} = 0\mu F$	-	65	-	dB
		$V_{OUT} = 10V$ , $f = 120\text{ Hz}$ , $C_{ADJ} = 10\mu F$	66	80	-	
Long Term Stability	-	$T_A = 125^\circ C$ , 1000 hrs	-	0.3	1	%
Thermal Resistance <sup>3</sup>	$R\theta_{JC}$	$T_{LOW} \leq T_J \leq T_{HIGH}$	-	2	-	$^\circ C/W$

3. Assembled in TO-3 package. Die performance is dependent on die attach, substrate choice & assembly method.

Typical Electrical Characteristics,  $T_J = 25^\circ C$  (unless noted otherwise)

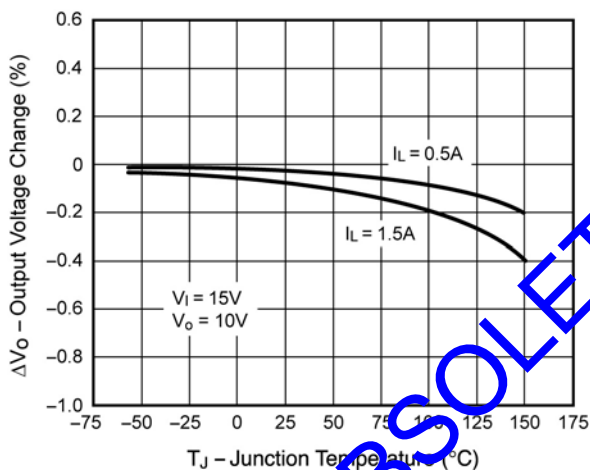

Figure 1 – Load Regulation

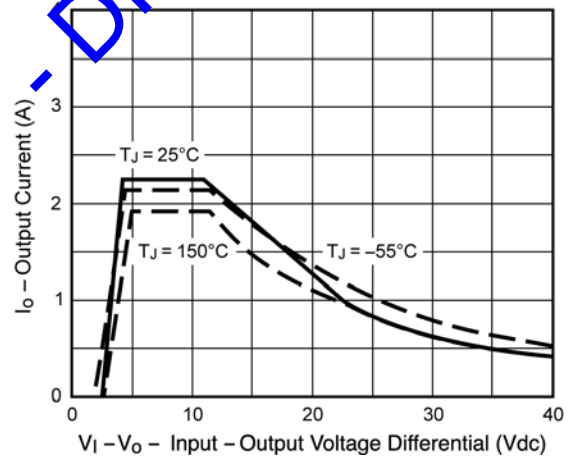

Figure 2 – Current Limit

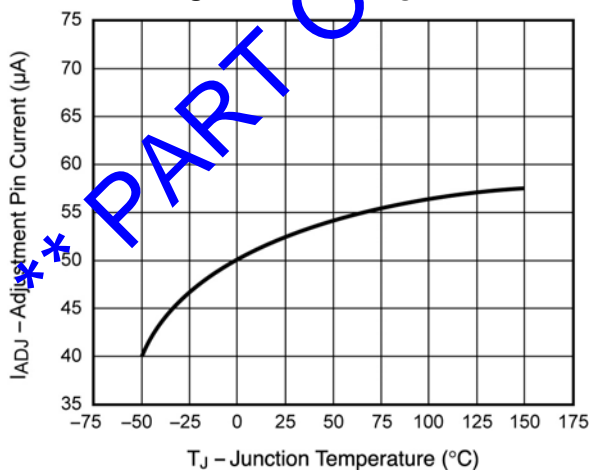

Figure 3 – Adjustment Pin Current

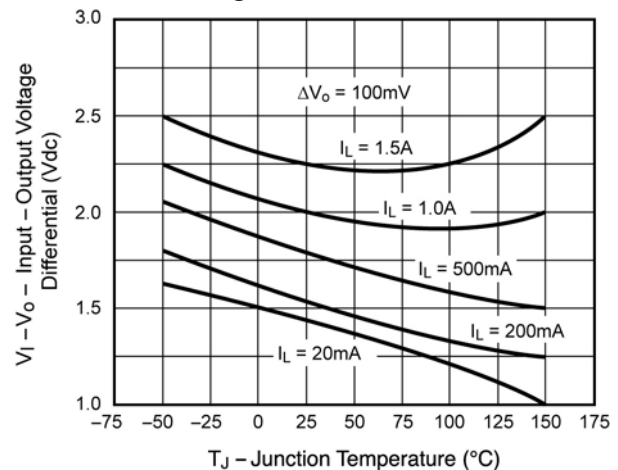

Figure 4 – Dropout Voltage





# Linear Voltage Regulator – LM317

Rev 1.0

03/03/18

Typical Electrical Characteristics,  $T_J = 25^\circ\text{C}$  (unless noted otherwise)

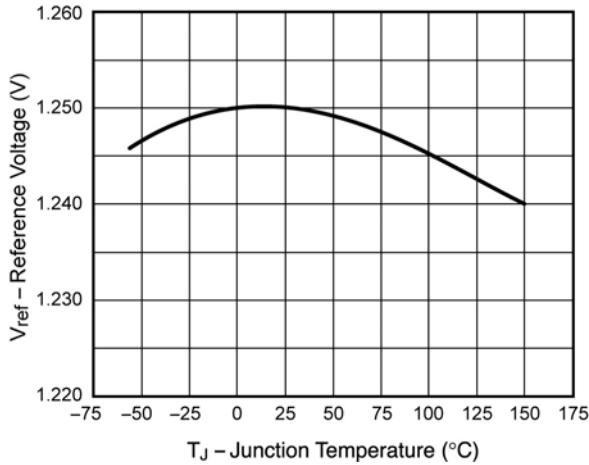

Figure 5 – Temperature Stability

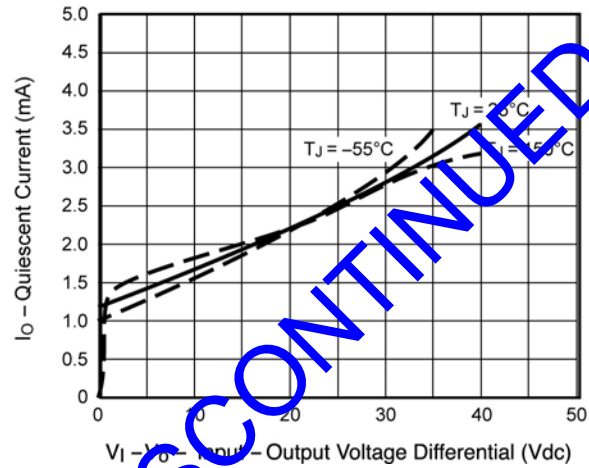

Figure 6 – Minimum Operating Current

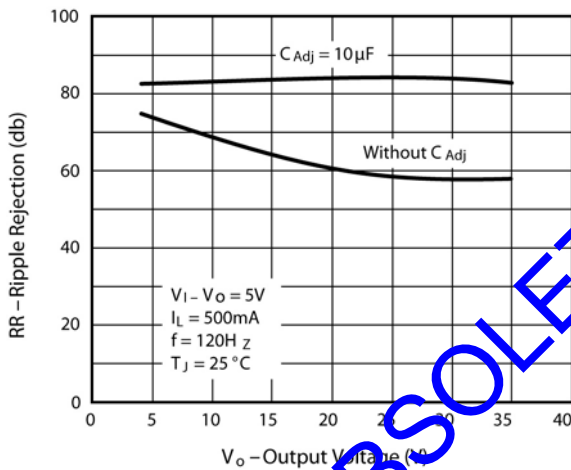

Figure 7 – Ripple Rejection versus Output Voltage

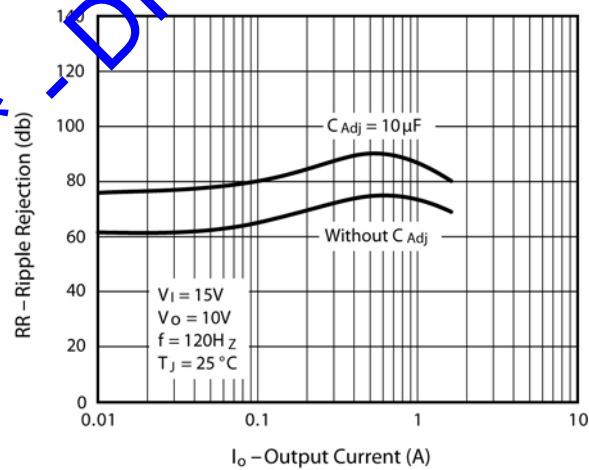

Figure 8 – Ripple Rejection versus Output Current

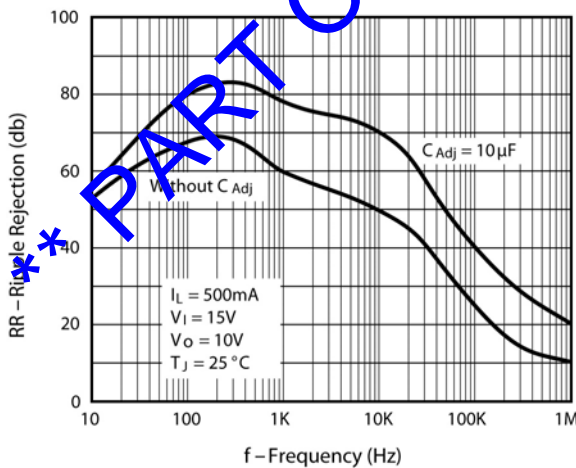

Figure 9 – Ripple Rejection versus Frequency

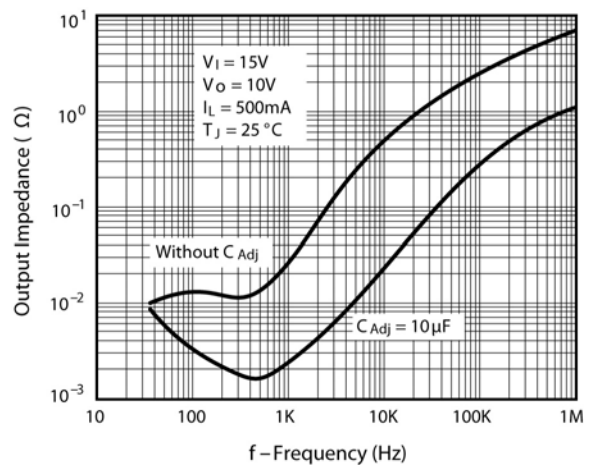

Figure 10 – Output Impedance





# Linear Voltage Regulator – LM317

Rev 1.0

03/03/18

Typical Electrical Characteristics,  $T_J = 25^\circ\text{C}$  (unless noted otherwise)

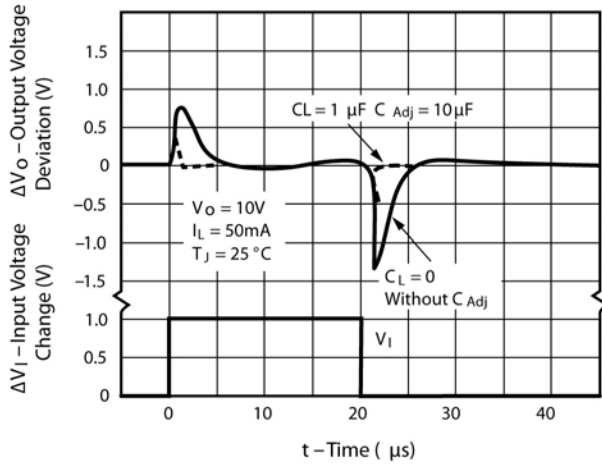

Figure 11– Line Transient Response

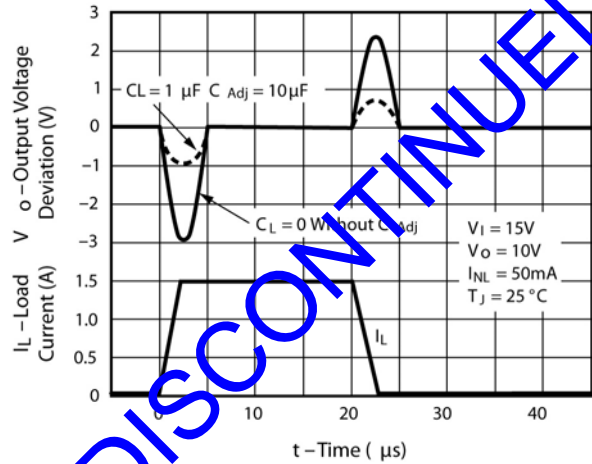

Figure 12– Load Transient Response

**DISCLAIMER:** The information given in this document shall in no event be regarded as a guarantee of conditions or characteristics. With respect to any examples or hints given herein, any typical values stated herein and/or any information regarding the application of the device, Silicon Supplies Ltd hereby disclaims any and all warranties and liabilities of any kind.

**LIFE SUPPORT POLICY:** Silicon Supplies Ltd components may be used in life support devices or systems only with the express written approval of Silicon Supplies Ltd, if a failure of such components can reasonably be expected to cause the failure of that life support device or system or to affect the safety or effectiveness of that device or system. Life support devices or systems are intended to be implanted in the human body or to support and/or maintain and sustain and/or protect human life. If they fail, it is reasonable to assume that the health of the user or other persons may be endangered.

