



# High Speed CMOS Logic – 74HC27

## Triple 3-Input NOR Gate in bare die form

Rev 1.0  
22/04/19

### Description

The 74HC27 triple 3-Input NOR Gate is fabricated on a 2.5µm 5V CMOS process combining high speed LSTTL performance with CMOS low power. The device contains three independent 3-input NOR gates performing Boolean function  $Y = (A + B + C)$  or  $Y = A \cdot B \cdot C$  in positive logic. Internal circuitry comprises of three stages and includes buffered output for high noise immunity and stability. Inputs are compatible with standard CMOS outputs; with pull-up resistors, they are compatible with LSTTL outputs.

### Features:

- Output Drive Capability: 10 LSTTL Loads
- Low Input Current: 1µA
- Outputs directly interface CMOS, NMOS and TTL
- Operating Voltage Range: 2V to 6V
- Function compatible with 54LS27
- High Noise Immunity CMOS process.

### Ordering Information

The following part suffixes apply:

- No suffix - MIL-STD-883 /2010B Visual Inspection

For High Reliability versions of this product please see

[54HC27](#)

### Die Dimensions in µm (mils)

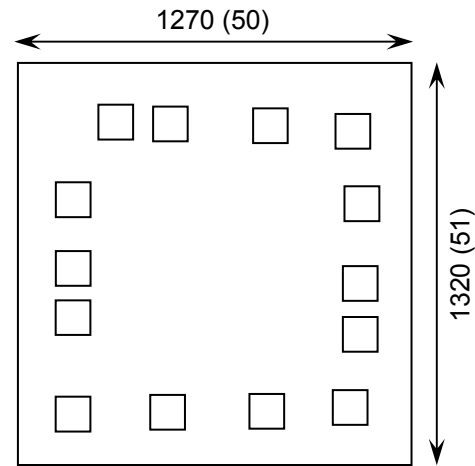

### Supply Formats:

- Default – Die in Waffle Pack (400 per tray capacity)
- ~~Sawn Wafer on Tape~~ – On request
- Unsawn Wafer – On request
- Die Thickness <=> 350µm(14 Mils) – On request
- Assembled into Ceramic Package – On request

### Mechanical Specification

Die Size (Unsawn)	1270 x 1320 50 x 51	µm mils
Minimum Bond Pad Size	108 x 108 4.25 x 4.25	µm mils
Die Thickness	350 (±20) 13.78 (±0.79)	µm mils
Top Metal Composition	Al 1%Si 1.1µm	
Back Metal Composition	N/A – Bare Si	





# High Speed CMOS Logic – 74HC27

Rev 1.0  
22/04/19

## Pad Layout and Functions

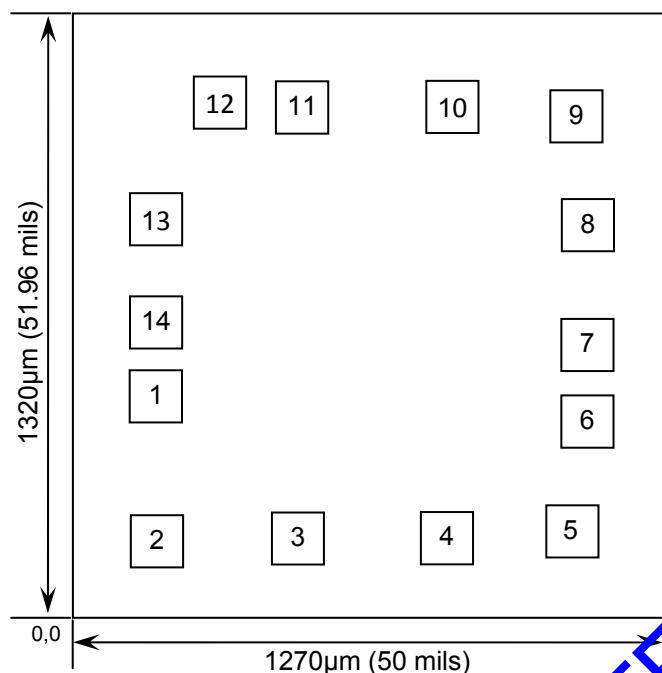

PAD	FUNCTION	COORDINATES (mm)	
		X	Y
1	1A	0.129	0.442
2	1B	0.132	0.124
3	2A	0.433	0.133
4	2B	0.751	0.133
5	2C	1.017	0.148
6	2Y	1.047	0.392
7	GND	1.047	0.561
8	3Y	1.047	0.828
9	3A	1.017	1.073
10	3B	0.751	1.088
11	3C	0.433	1.088
12	1Y	0.262	1.095
13	1C	0.128	0.838
14	V <sub>CC</sub>	0.129	0.606

CONNECT CHIP BACK TO V<sub>CC</sub> OR FLOAT

## Logic Diagram

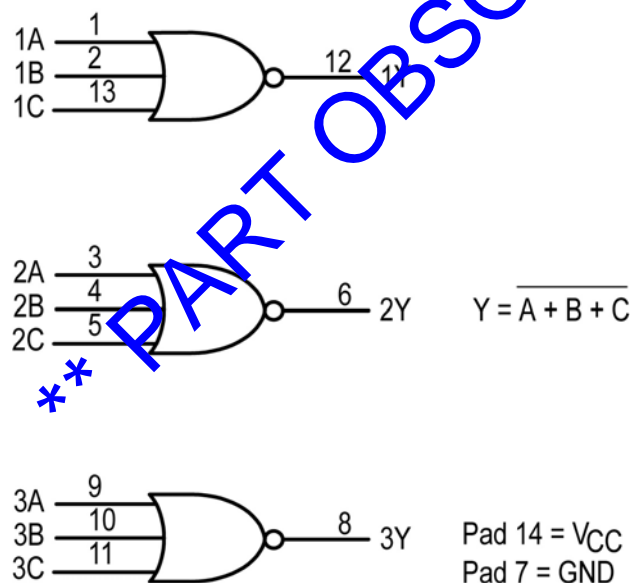

## Truth Table

INPUTS			OUTPUT
A	B	C	Y
H	X	X	L
X	H	X	L
X	X	H	L
L	L	L	H

H = High level (steady state)  
L = Low level (steady state)  
X = don't care





# High Speed CMOS Logic – 74HC27

Rev 1.0

22/04/19

## Absolute Maximum Ratings<sup>1</sup>

PARAMETER	SYMBOL	VALUE	UNIT
DC Supply Voltage (Referenced to GND)	$V_{CC}$	-0.5 to +7.0	V
DC Input Voltage (Referenced to GND)	$V_{IN}$	-1.5 to $V_{CC} + 1.5$	V
DC Output Voltage (Referenced to GND)	$V_{OUT}$	-0.5 to $V_{CC} + 0.5$	V
DC Input Current	$I_{IN}$	$\pm 20$	mA
DC Output Current, per pad	$I_{OUT}$	$\pm 25$	mA
DC Supply Current, $V_{CC}$ or GND	$I_{CC}$	$\pm 50$	mA
Power Dissipation in Still Air <sup>2</sup>	$P_D$	750	mW
Storage Temperature Range	$T_{STG}$	-65 to +150	$^{\circ}C$

1. Operation above the absolute maximum rating may cause device failure. Operation at the absolute maximum ratings, for extended periods, may reduce device reliability. 2. Measured in plastic DIP package, results in die form are dependent on die attach and assembly method.

## Recommended Operating Conditions<sup>3</sup> (Voltages referenced to GND)

PARAMETER	SYMBOL	MIN	MAX	UNITS	
Supply Voltage	$V_{CC}$	2	6	V	
DC Input or Output Voltage	$V_{IN}, V_{OUT}$	0	$V_{CC}$	V	
Operating Temperature Range	$T_J$	-40	+85	$^{\circ}C$	
Input Rise or Fall Times	$t_r, t_f$	$V_{CC} = 2V$	0	1000	ns
		$V_{CC} = 4.5V$	0	500	
		$V_{CC} = 6.0V$	0	400	

3. This device contains protection circuitry to guard against damage due to high static voltages or electric fields. However, precautions must be taken to avoid applications of any voltage higher than maximum rated voltages to this high-impedance circuit. For proper operation,  $V_{IN}$  and  $V_{OUT}$  should be constrained to the range  $GND \leq (V_{IN} \text{ or } V_{OUT}) \leq V_{CC}$ . Unused inputs must always be tied to an appropriate logic voltage level (e.g., either GND or  $V_{CC}$ ). Unused outputs must be left open.

## DC Electrical Characteristics (Voltages Referenced to GND)

PARAMETER	SYMBOL	$V_{CC}$	CONDITIONS	LIMITS			UNITS
				25 $^{\circ}C$	85 $^{\circ}C$	FULL RANGE <sup>4</sup>	
Minimum High-Level Input Voltage	$V_{IH}$	2.0V	$V_{OUT} = 0.1V \text{ or } V_{CC} - 0.1V$ $ I_{OUT}  \leq 20\mu A$	1.5	1.5	1.5	V
		4.5V		3.15	3.15	3.15	
		6.0V		4.2	4.2	4.2	
Maximum Low-Level Input Voltage	$V_{IL}$	2.0V	$V_{OUT} = 0.1V \text{ or } V_{CC} - 0.1V$ $ I_{OUT}  \leq 20\mu A$	0.3	0.3	0.3	V
		4.5V		0.9	0.9	0.9	
		6.0V		1.2	1.2	1.2	

4. -40 $^{\circ}C \leq T_J \leq +85^{\circ}C$





# High Speed CMOS Logic – 74HC27

Rev 1.0

22/04/19

## DC Electrical Characteristics Continued (Voltages Referenced to GND)

PARAMETER	SYMBOL	V <sub>CC</sub>	CONDITIONS	LIMITS			UNITS
				25°C	85°C	FULL RANGE <sup>4</sup>	
Minimum High-Level Output Voltage	V <sub>OH</sub>	2.0V	V <sub>IN</sub> = V <sub>IH</sub> or V <sub>IL</sub>  I <sub>OUT</sub>   ≤ 20μA	1.9	1.9	1.9	V
		4.5V		4.4	4.4	4.4	
		6.0V		5.9	5.9	5.9	
		4.5V	V <sub>IN</sub> = V <sub>IH</sub> or V <sub>IL</sub>  I <sub>OUT</sub>   ≤ 4.0mA	3.98	3.84	3.84	
		6.0V	V <sub>IN</sub> = V <sub>IH</sub> or V <sub>IL</sub>  I <sub>OUT</sub>   ≤ 5.2mA	5.48	5.34	5.34	
Maximum Low-Level Output Voltage	V <sub>OL</sub>	2.0V	V <sub>IN</sub> = V <sub>IL</sub> or V <sub>IL</sub>  I <sub>OUT</sub>   ≤ 20μA	0.1	0.1	0.1	V
		4.5V		0.1	0.1	0.1	
		6.0V		0.1	0.1	0.1	
		4.5V	V <sub>IN</sub> = V <sub>IL</sub> or V <sub>IL</sub>  I <sub>OUT</sub>   ≤ 4.0mA	0.26	0.33	0.33	
		6.0V	V <sub>IN</sub> = V <sub>IL</sub> or V <sub>IL</sub>  I <sub>OUT</sub>   ≤ 5.2mA	0.26	0.33	0.33	
Maximum Input Leakage Current	I <sub>IN</sub>	6.0V	V <sub>IN</sub> = V <sub>CC</sub> or GND	±0.1	±1.0	±1.0	μA
Maximum Quiescent Supply Leakage Current	I <sub>CC</sub>	6.0V	V <sub>IN</sub> = V <sub>CC</sub> or GND I <sub>OUT</sub> = 0μA	2	20	20	μA

## AC Electrical Characteristics<sup>5</sup>

PARAMETER	SYMBOL	V <sub>CC</sub>	CONDITIONS	LIMITS			UNITS
				25°C	85°C	FULL RANGE <sup>4</sup>	
Maximum Propagation Delay, Input A, 50pF C to Output Y (Figure 1,2)	t <sub>PLH</sub> , t <sub>PHL</sub>	2.0V	C <sub>L</sub> = 50pF, t <sub>r</sub> = t <sub>f</sub> = 6ns	90	115	115	ns
		4.5V		18	23	23	
		6.0V		15	20	20	
Maximum Output Rise and Fall Time, Any Output (Figure 1,2)	t <sub>TLH</sub> , t <sub>THL</sub>	2.0V	C <sub>L</sub> = 50pF, t <sub>r</sub> = t <sub>f</sub> = 6ns	75	95	95	ns
		4.5V		15	19	19	
		6.0V		13	16	16	

5. Not production tested in die form, characterized by chip design and tested in package.





# High Speed CMOS Logic – 74HC27

Rev 1.0  
22/04/19

## AC Electrical Characteristics Continued<sup>5</sup>

PARAMETER	SYMBOL	V <sub>CC</sub>	CONDITIONS	LIMITS			UNITS
				25°C	85°C	FULL RANGE <sup>4</sup>	
Maximum Input Capacitance	C <sub>IN</sub>	-	-	10	10	10	pF
Power Dissipation Capacitance Per Gate <sup>6</sup>	C <sub>PD</sub>	-	T <sub>J</sub> = 25°C, V <sub>CC</sub> = 5.0V	TYPICAL			pF
				27			

6. Used to determine the no-load dynamic power consumption:  $P_D = C_{PD} V_{CC}^2 f + I_{CC} V_{CC}$ .

## Switching Waveform

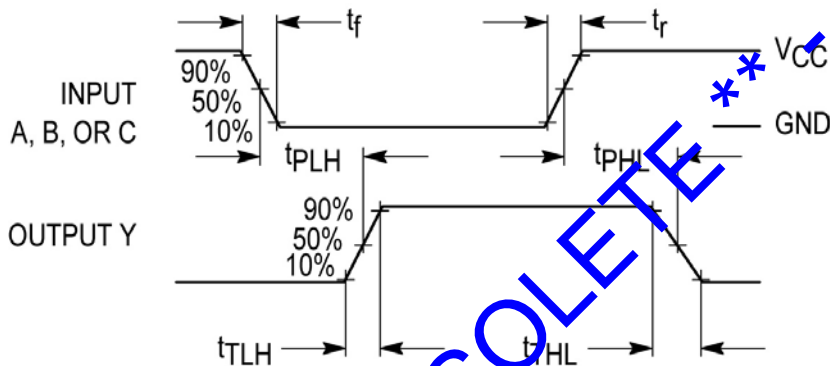
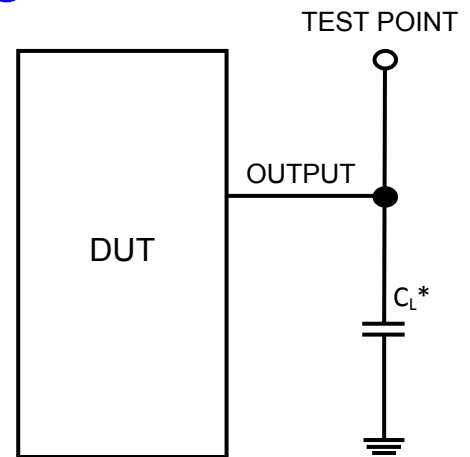

Figure 1 – Propagation Delay & Output Transition Time

## Test Circuit



\* Includes all probe and jig capacitance

Figure 2

**DISCLAIMER:** The information given in this document shall in no event be regarded as a guarantee of conditions or characteristics. With respect to any examples or hints given herein, any typical values stated herein and/or any information regarding the application of the device, Silicon Supplies Ltd hereby disclaims any and all warranties and liabilities of any kind.

**LIFE SUPPORT POLICY:** Silicon Supplies Ltd components may be used in life support devices or systems only with the express written approval of Silicon Supplies Ltd, if a failure of such components can reasonably be expected to cause the failure of that life support device or system or to affect the safety or effectiveness of that device or system. Life support devices or systems are intended to be implanted in the human body or to support and/or maintain and sustain and/or protect human life. If they fail, it is reasonable to assume that the health of the user or other persons may be endangered.

