



High Speed CMOS Logic – 74HC244

Octal 3-State Non-Inverting Buffer / Line Driver / Line Receiver in bare die form

Rev 1.1
01/05/18

Description

The 74HC244 is fabricated using a 2.5µm 5V CMOS process and has the same high speed performance of LSTTL combined with CMOS low power consumption. The device can be used as two 4-bit buffers or one 8-bit buffer and features non-inverting inputs with two output enables, each controlling four of the 3-state outputs. The device is specifically designed to improve performance and density in clock drivers, 3-state memory address drivers and bus orientated transmitters and receivers. Inputs include clamp diodes that enable the use of current limiting resistors to interface inputs to voltages in excess of V_{CC}

Features:

- Output Drive Capability: 15 LSTTL Loads
- Low Input Current: 1µA
- Outputs directly interface CMOS, NMOS and TTL
- Operating Voltage Range: 2V to 6V
- CMOS High Noise Immunity
- Function compatible with 74LS244.

Ordering Information

The following part suffixes apply:

- No suffix - MIL-STD-883 /2010B Visual Inspection

For High Reliability versions of this product please see

[54HC244](#)

Die Dimensions in µm (mils)

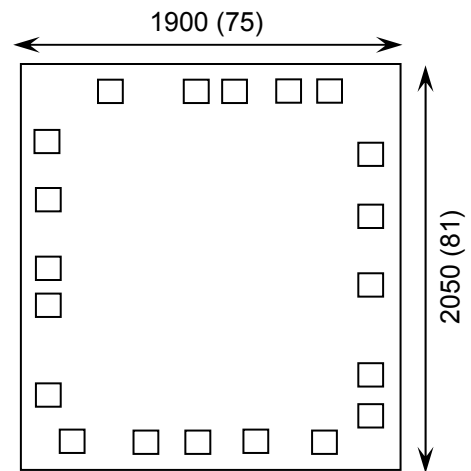

Supply Formats:

- Default – Die in Waffle Pack (100 per tray capacity)
- ****** Sawn Wafer on Tape – On request
- Unsawn Wafer – On request
- Die Thickness <=> 350µm(14 Mils) – On request
- Assembled into Ceramic Package – On request

Mechanical Specification

Die Size (Unsawn)	1900 x 2050 75 x 81	µm mils
Minimum Bond Pad Size	100 x 100 3.94 x 3.94	µm mils
Die Thickness	350 (±20) 13.78 (±0.79)	µm mils
Top Metal Composition	Al 1%Si 1.1µm	
Back Metal Composition	N/A – Bare Si	





High Speed CMOS Logic – 74HC244

Rev 1.1
01/05/18

Pad Layout and Functions

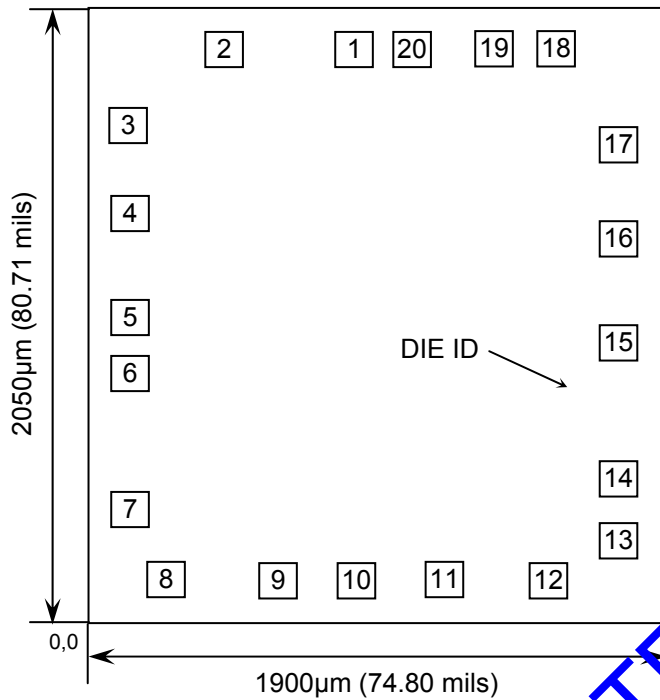

PAD	FUNCTION
1	ENABLE A
2	YA1
3	YB4
4	A2
5	YB3
6	A3
7	YB2
8	A4
9	YB1
10	GND
11	B1
12	YA4
13	B2
14	YA3
15	B3
16	YA2
17	B4
18	YA1
19	ENABLE B
20	V _{CC}

CONNECT CHIP BACK TO V_{CC} OR FLOAT

Logic Diagram

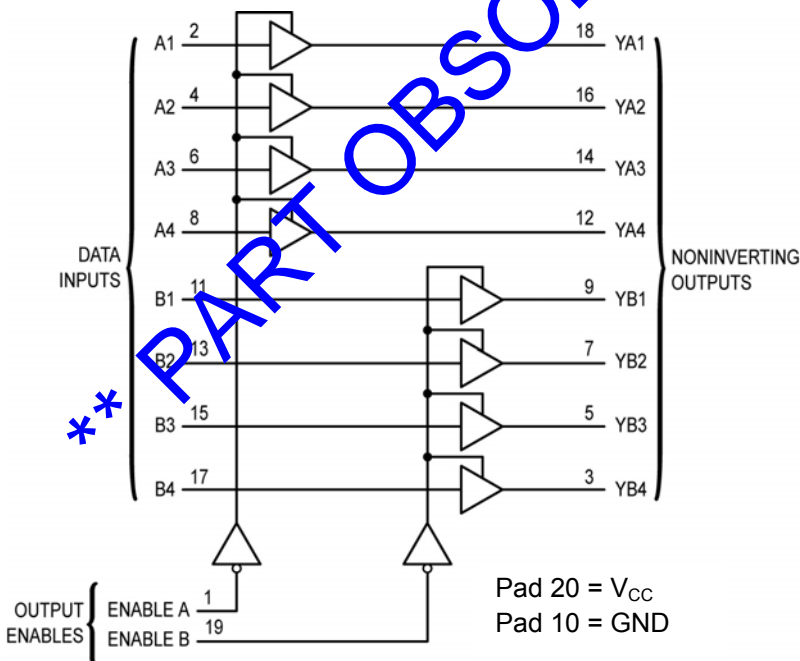

Truth Table

INPUTS		OUTPUTS
ENABLE A	ENABLE B	A, B
L	L	L
L	H	H
H	X	Z

H = High level (steady state)

L = Low level (steady state)

X = Don't care

Z = High impedance





High Speed CMOS Logic – 74HC244

Rev 1.1
01/05/18

Pad Descriptions

ADDRESS INPUTS

A1, A2, A3, A4, B1, B2, B3, B4
(Pads 2, 4, 6, 8, 11, 13, 15, 17)

Data input pins. Data on these pins appear in non-inverted form on the corresponding Y outputs, when the outputs are enabled.

CONTROL INPUTS

Enable A, Enable B (Pads 1, 19)

Output enables (active-low). When a low level is applied to these pins, the outputs are enabled and the devices function as non-inverting buffers. When a high level is applied, the outputs assume the high impedance state.

OUTPUTS

YA1, YA2, YA3, YA4, YB1, YB2, YB3, YB4
(Pads 18, 16, 14, 12, 9, 7, 5, 3)

Device outputs. Depending upon the state of the output- enable pins, these outputs are either non-inverting outputs or high-impedance outputs.

Absolute Maximum Ratings¹

PARAMETER	SYMBOL	VALUE	UNIT
DC Supply Voltage (Referenced to GND)	V_{CC}	-0.5 to +7.0	V
DC Input Voltage (Referenced to GND)	V_{IN}	-1.5 to $V_{CC} + 1.5$	V
DC Output Voltage (Referenced to GND)	V_{OUT}	-0.5 to $V_{CC} + 0.5$	V
DC Input Current, per pin	I_{IN}	±20	mA
DC Output Current, per pin	I_{OUT}	±35	mA
DC V_{CC} or GND Current, per pin	I_{CC}	±75	mA
Power Dissipation in Still Air ²	P_D	750	mW
Storage Temperature Range	T_{STG}	-65 to 150	°C

1. Operation above the absolute maximum ratings may cause device failure. Operation at the absolute maximum ratings, for extended periods, may reduce device reliability. 2. Measured in plastic DIP package, results in die form are dependent on die attach and assembly method.

Recommended Operating Conditions³ (Voltages referenced to GND)

PARAMETER	SYMBOL	MIN	MAX	UNITS	
DC Supply Voltage	V_{CC}	2	6	V	
DC Input or Output Voltage	V_{IN}, V_{OUT}	0	V_{CC}	V	
Operating Temperature Range	T_A	0	+85	°C	
Input Rise and Fall Time	t_r, t_f	$V_{CC} = 2.0V$	0	1000	ns
		$V_{CC} = 4.5V$	0	500	
		$V_{CC} = 6.0V$	0	400	

3. This device contains protection circuitry to guard against damage due to high static voltages or electric fields. However, precautions must be taken to avoid applications of any voltage higher than maximum rated voltages to this high-impedance circuit. For proper operation, V_{IN} and V_{OUT} should be constrained to the range $GND \leq (V_{IN} \text{ or } V_{OUT}) \leq V_{CC}$. Unused inputs must always be tied to an appropriate logic voltage level (e.g., either GND or V_{CC}). Unused outputs must be left open.





High Speed CMOS Logic – 74HC244

Rev 1.1

01/05/18

DC Electrical Characteristics (Voltages Referenced to GND)

PARAMETER	SYMBOL	V _{CC}	CONDITIONS	LIMITS			UNITS
				25°C	85°C	FULL RANGE*	
Minimum High-Level Input Voltage	V _{IH}	2.0V	V _{OUT} = V _{CC} - 0.1V I _{OUT} ≤ 20μA	1.5	1.5	1.5	V
		3.0V		2.1	2.1	2.1	
		4.5V		3.15	3.15	3.15	
		6.0V		4.2	4.2	4.2	
Maximum Low-Level Input Voltage	V _{IL}	2.0V	V _{OUT} = 0.1V I _{OUT} ≤ 20μA	0.5	0.5	0.5	V
		3.0V		0.9	0.9	0.9	
		4.5V		1.35	1.35	1.35	
		6.0V		1.8	1.8	1.8	
Minimum High-Level Output Voltage	V _{OH}	2.0V	V _{IN} = V _{IH} I _{OUT} ≤ 20μA	1.9	1.9	1.9	V
		4.5V		4.4	4.4	4.4	
		6.0V		5.9	5.9	5.9	
	V _{OH}	3.0V	V _{IN} = V _{IH} I _{OUT} ≤ 2.4mA	2.48	2.34	2.34	V
		4.5V	V _{IN} = V _{IH} I _{OUT} ≤ 6.0mA	3.98	3.84	3.84	
		6.0V	V _{IN} = V _{IH} I _{OUT} ≤ 7.8mA	5.48	5.34	5.34	
Maximum Low-Level Output Voltage	V _{OL}	2.0V	V _{IN} = V _{IL} I _{OUT} ≤ 20μA	0.1	0.1	0.1	V
		4.5V		0.1	0.1	0.1	
		6.0V		0.1	0.1	0.1	
	V _{OL}	3.0V	V _{IN} = V _{IL} I _{OUT} ≤ 2.4mA	0.26	0.33	0.33	V
		4.5V	V _{IN} = V _{IL} I _{OUT} ≤ 6.0mA	0.26	0.33	0.33	
		6.0V	V _{IN} = V _{IL} I _{OUT} ≤ 7.8mA	0.26	0.33	0.33	
Maximum Input Leakage Current	I _{IN}	6.0V	V _{IN} = V _{CC} or GND	±0.1	±1.0	±1.0	μA
Maximum 3-State leakage current	I _{OZ}	6.0V	V _{OUT} = V _{CC} or 0 V _{IN} = V _{IL} or V _{IH}	±0.5	±5.0	±5.0	μA
Maximum Quiescent Supply Leakage Current	I _{CC}	6.0V	V _{IN} = V _{CC} or GND I _{OUT} = 0μA	4	40	40	μA

4. 0°C ≤ T_J ≤ +85°C





High Speed CMOS Logic – 74HC244

Rev 1.1
01/05/18

AC Electrical Characteristics⁵

PARAMETER	SYMBOL	V _{CC}	CONDITIONS	LIMITS			UNITS
				25°C	85°C	FULL RANGE ⁴	
Maximum Propagation Delay, A to YA or B to YB (Figure 1, 3)	t _{PLH} , t _{PHL}	2.0V	C _L = 50pF, t _r = t _f = 6ns	96	115	115	ns
		3.0V		50	60	60	
		4.5V		18	23	23	
		6.0V		15	20	20	
Maximum Propagation Delay, Output Enable to YA or YB (Figure 2,4)	t _{PLZ} , t _{PHZ}	2.0V	C _L = 50pF, t _r = t _f = 6ns	110	140	140	ns
		3.0V		60	70	70	
		4.5V		22	28	28	
		6.0V		19	24	24	
Maximum Propagation Delay, Output Enable to YA or YB (Figure 2,4)	t _{PZL} , t _{PZH}	2.0V	C _L = 50pF, t _r = t _f = 6ns	110	140	140	ns
		3.0		60	70	70	
		4.5V		22	28	28	
		6.0V		19	24	24	
Maximum Output Rise and Fall Time (Figure 1, 3)	t _{TLH} , t _{THL}	2.0V	C _L = 50pF, t _r = t _f = 6ns	60	75	75	ns
		3.0V		23	27	27	
		4.5V		12	15	15	
		6.0V		10	13	13	
Maximum Input Capacitance	C _{IN}	-	-	10	10	10	pF
Maximum Three-State Output Capacitance (Output in High-Impedance State)	C _{OUT}	-	-	15	15	15	pF
Power Dissipation Capacitance (Per Buffer) ⁵	C _{PD}	-	T _A = 25°C, V _{CC} = 5.0V	TYPICAL			pF
				34			

5. Not production tested in die form, characterized by chip design and tested in package LAT.

6. Used to determine the no-load dynamic power consumption: $P_D = C_{PD} V_{CC}^2 f + I_{CC} V_{CC}$.

** PART OBSOLETE **

DISCONTINUED





High Speed CMOS Logic – 74HC244

Rev 1.1
01/05/18

Switching Waveforms

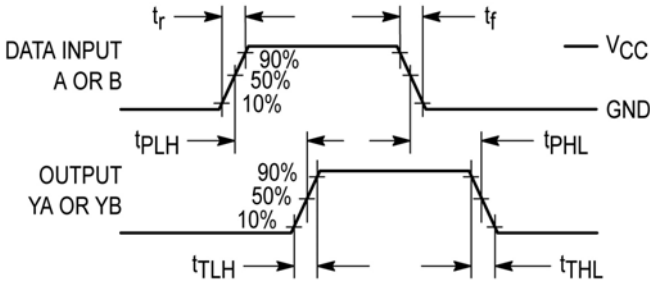

Figure 1 – Propagation Delay
Input A or B to Output YA or YB

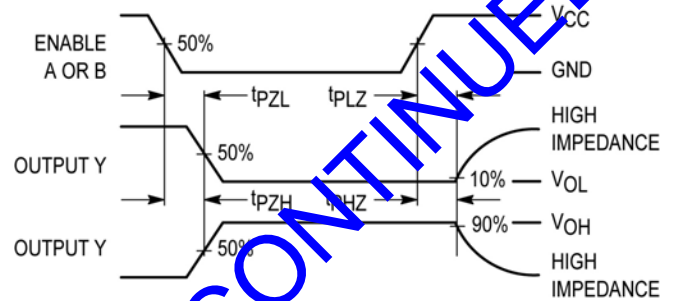
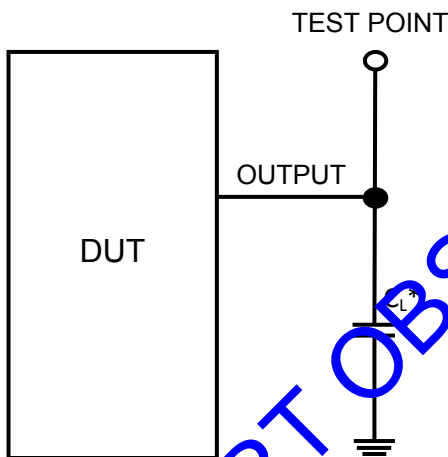

Figure 2 – Propagation Delay
Output Enable to Output YA or YB

Test Circuits



* Includes all probe and jig capacitance

Figure 3

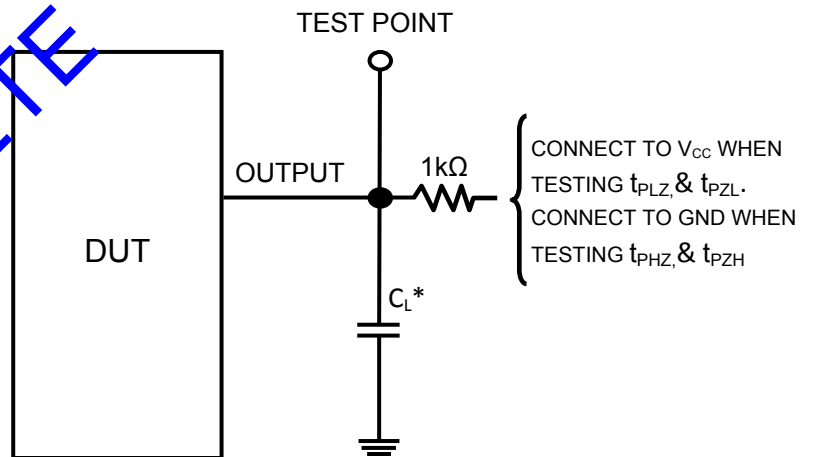

* Includes all probe and jig capacitance

Figure 4

DISCLAIMER: The information given in this document shall in no event be regarded as a guarantee of conditions or characteristics. With respect to any examples or hints given herein, any typical values stated herein and/or any information regarding the application of the device, Silicon Supplies Ltd hereby disclaims any and all warranties and liabilities of any kind.

LIFE SUPPORT POLICY: Silicon Supplies Ltd components may be used in life support devices or systems only with the express written approval of Silicon Supplies Ltd, if a failure of such components can reasonably be expected to cause the failure of that life support device or system or to affect the safety or effectiveness of that device or system. Life support devices or systems are intended to be implanted in the human body or to support and/or maintain and sustain and/or protect human life. If they fail, it is reasonable to assume that the health of the user or other persons may be endangered.

