



High Speed CMOS Logic – 74HC08

Quad 2-Input AND Gate in bare die form

Rev 1.0
07/02/19

Description

The 74HC08 quad 2-input AND gate is fabricated using a 2.5µm 5V CMOS process combining high speed LSTTL performance with CMOS low power. The device consists of four independent 2-input AND gates with standard push-pull outputs and performs the Boolean function $Y = A \bullet B$ or $Y = A + B$. Device inputs are compatible with standard CMOS outputs; with pull-up resistors, they are compatible with LSTTL outputs. All inputs are protected against ESD and excess voltage transients.

Features:

- Output Drive Capability: 10 LSTTL Loads
- Low Input Current: 1µA
- Outputs directly interface CMOS, NMOS and TTL
- Operating Voltage Range: 2V to 6V
- Function compatible with 74LS08
- High Noise Immunity CMOS process.

Ordering Information

The following part suffixes apply:

- No suffix - MIL-STD-883 /2010B Visual Inspection

For High Reliability versions of this product please see

[54HC08](#)

Die Dimensions in µm (mils)

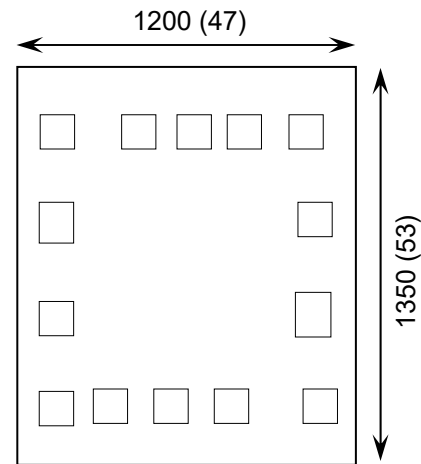

Supply Formats:

- Default – Die in Waffle Pack (400 per tray capacity)
- ~~Sawn Wafer on Tape~~ – On request
- Unsawn Wafer – On request
- Die Thickness <=> 350µm(14 Mils) – On request
- Assembled into Ceramic Package – On request

Mechanical Specification

Die Size (Unsawn)	1200 x 1350 47 x 53	µm mils
Minimum Bond Pad Size	85 x 85 3.35 x 3.35	µm mils
Die Thickness	350 (±20) 13.78 (±0.79)	µm mils
Top Metal Composition	Al 1%Si 1.1µm	
Back Metal Composition	N/A – Bare Si	





High Speed CMOS Logic – 74HC08

Rev 1.0
07/02/19

Pad Layout and Functions

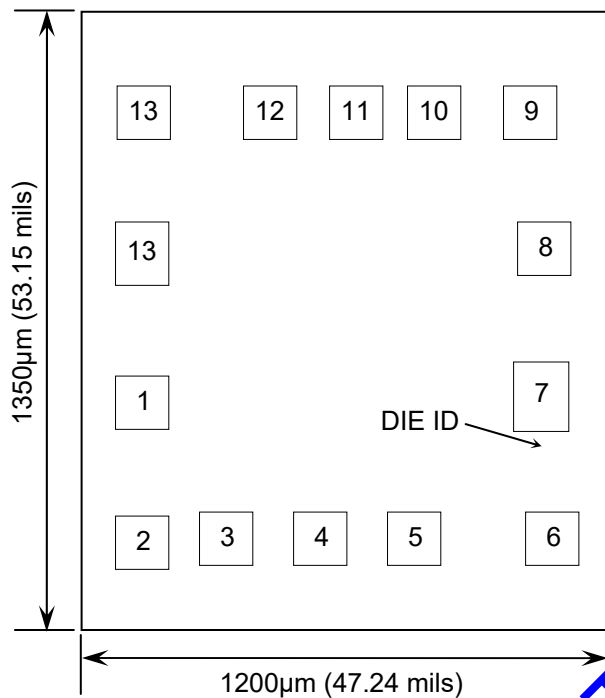

PAD	FUNCTION	COORDINATES (µm)	
		X	Y
1	1A	132	443
2	1B	132	126
3	1Y	315	129
4	2A	485	129
5	2B	802	129
6	2Y	1087	129
7	GND	991	504
8	3Y	991	807
9	3A	971	1105
10	3B	722	1105
11	4Y	551	1105
12	4A	381	1105
13	4B	132	1105
14	V _{CC}	132	650

CONNECT CHIP BACK TO V_{CC} OR FLOAT

Logic Diagram

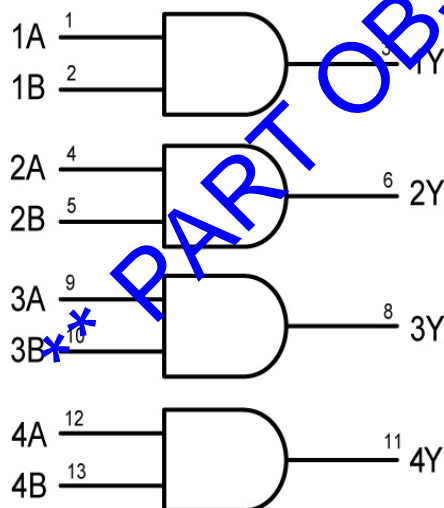

Function Table

INPUTS		OUTPUT
A	B	Y
L	L	L
L	H	L
H	L	L
H	H	H

H = High level (steady state)
L = Low level (steady state)





High Speed CMOS Logic – 74HC08

Rev 1.0

07/02/19

Absolute Maximum Ratings¹

PARAMETER	SYMBOL	VALUE	UNIT
DC Supply Voltage (Referenced to GND)	V_{CC}	-0.5 to +7.0	V
DC Input Voltage (Referenced to GND)	V_{IN}	-0.5 to $V_{CC} + 0.5$	V
DC Output Voltage (Referenced to GND)	V_{OUT}	-0.5 to $V_{CC} + 0.5$	V
DC Input Current	I_{IN}	± 20	mA
DC Output Current, per pad	I_{OUT}	± 25	mA
DC Supply Current, V_{CC} or GND, per pad	I_{CC}	± 50	mA
Power Dissipation in Still Air ²	P_D	750	mW
Storage Temperature Range	T_{STG}	-65 to +150	$^{\circ}C$

1. Operation above the absolute maximum rating may cause device failure. Operation at the absolute maximum ratings, for extended periods, may reduce device reliability. 2. Measured in plastic DIP package, results in die form are dependent on die attach and assembly method.

Recommended Operating Conditions³ (Voltages referenced to GND)

PARAMETER	SYMBOL	MIN	MAX	UNITS	
Supply Voltage	V_{CC}	2	6	V	
DC Input or Output Voltage	V_{IN}, V_{OUT}	0	V_{CC}	V	
Operating Temperature Range	T_J	-40	+85	$^{\circ}C$	
Input Rise or Fall Times	t_r, t_f	$V_{CC} = 2V$	0	1000	ns
		$V_{CC} = 4.5V$	0	500	
		$V_{CC} = 5.0V$	0	400	

3. This device contains protection circuitry to guard against damage due to high static voltages or electric fields. However, precautions must be taken to avoid applications of any voltage higher than maximum rated voltages to this high-impedance circuit. For proper operation, V_{IN} and V_{OUT} should be constrained to the range $GND \leq (V_{IN} \text{ or } V_{OUT}) \leq V_{CC}$. Unused inputs must always be tied to an appropriate logic voltage level (e.g., either GND or V_{CC}). Unused outputs must be left open.

DC Electrical Characteristics (Voltages Referenced to GND)

PARAMETER	SYMBOL	V_{CC}	CONDITIONS	LIMITS			UNITS
				25 $^{\circ}C$	85 $^{\circ}C$	FULL RANGE ⁴	
Minimum High-Level Input Voltage	V_{IH}	2.0V	$V_{OUT} = 0.1V \text{ or } V_{CC} - 0.1V$ $ I_{OUT} \leq 20\mu A$	1.5	1.5	1.5	V
		3.0V		2.1	2.1	2.1	
		4.5V		3.15	3.15	3.15	
		6.0V		4.2	4.2	4.2	
Maximum Low-Level Input Voltage	V_{IL}	2.0V	$V_{OUT} = 0.1V \text{ or } V_{CC} - 0.1V$ $ I_{OUT} \leq 20\mu A$	0.5	0.5	0.5	V
		3.0V		0.9	0.9	0.9	
		4.5V		1.35	1.35	1.35	
		6.0V		1.8	1.8	1.8	





High Speed CMOS Logic – 74HC08

Rev 1.0

07/02/19

DC Electrical Characteristics Continued (Voltages Referenced to GND)

PARAMETER	SYMBOL	V _{CC}	CONDITIONS	LIMITS			UNITS
				25°C	85°C	FULL RANGE ⁴	
Minimum High-Level Output Voltage	V _{OH}	2.0V	V _{IN} = V _{IH} or V _{IL} I _{OUT} ≤ 20μA	1.9	1.9	1.9	V
		4.5V		4.4	4.4		
		6.0V		5.9	5.9		
		3.0V	V _{IN} = V _{IH} or V _{IL} I _{OUT} ≤ 2.4mA	2.48	2.34	2.20	V
		4.5V		3.98	3.84	3.70	
		6.0V		5.48	5.34	5.20	
Maximum Low-Level Output Voltage	V _{OL}	2.0V	V _{IN} = V _{IL} or V _{IL} I _{OUT} ≤ 20μA	0.1	0.1	0.1	V
		4.5V		0.1	0.1	0.1	
		6.0V		0.1	0.1	0.1	
		3.0V	V _{IN} = V _{IL} or V _{IL} I _{OUT} ≤ 2.4mA	0.26	0.33	0.40	V
		4.5V		0.26	0.33	0.40	
		6.0V		0.26	0.33	0.40	
Maximum Input Leakage Current	I _{IN}	6.0V	V _{IN} = V _{CC} or GND	±0.1	±1.0	±1.0	μA
Maximum Quiescent Supply Leakage Current	I _{CC}	6.0V	V _{IN} = V _{CC} or GND I _{OUT} = 0μA	1	10	40	μA

4. -40°C ≤ T_J ≤ +85°C

AC Electrical Characteristics⁵

PARAMETER	SYMBOL	V _{CC}	CONDITIONS	LIMITS			UNITS
				25°C	85°C	FULL RANGE ⁴	
Maximum Propagation Delay, Input A or B to Output Y (Figure 1,2)	t _{PLH} , t _{PHL}	2.0V	C _L = 50pF, Input t _r = t _f = 6ns	75	95	110	ns
		3.0V		30	40	55	
		4.5V		15	19	22	
		6.0V		13	16	19	
Maximum Output Rise and Fall Time, Any Output (Figure 1,2)	t _{TLH} , t _{THL}	2.0V	C _L = 50pF, Input t _r = t _f = 6ns	75	95	110	ns
		3.0V		27	32	36	
		4.5V		15	19	22	
		6.0V		13	16	19	

5. Not production tested in die form, characterized by chip design and tested in package.





High Speed CMOS Logic – 74HC08

Rev 1.0
24/11/17

AC Electrical Characteristics Continued⁵

PARAMETER	SYMBOL	V _{CC}	CONDITIONS	LIMITS			UNITS
				25°C	85°C	FULL RANGE ⁴	
Maximum Input Capacitance	C _{IN}	-	-	10	10	10	pF
Power Dissipation Capacitance Per Gate ⁶	C _{PD}	-	T _J = 25°C, V _{CC} = 5.0V	TYPICAL			pF
				20			

6. Used to determine the no-load dynamic power consumption: $P_D = C_{PD} V_{CC}^2 f + I_{CC} V_{CC}$.

Switching Waveform

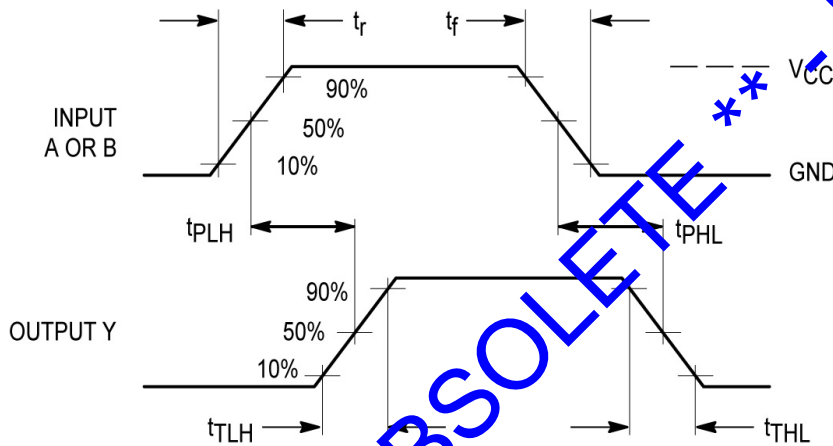
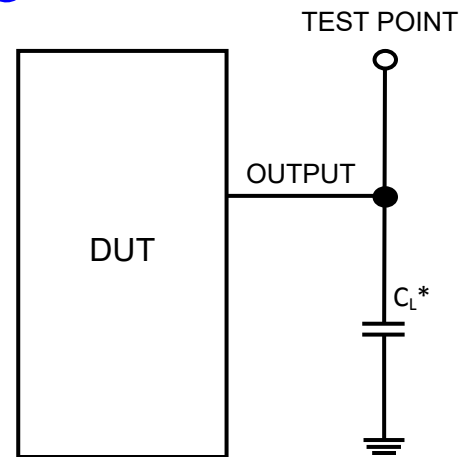

Figure 1 – Propagation Delay & Output Transition Time

Test Circuit



* Includes all probe and jig capacitance

Figure 2

DISCLAIMER: The information given in this document shall in no event be regarded as a guarantee of conditions or characteristics. With respect to any examples or hints given herein, any typical values stated herein and/or any information regarding the application of the device, Silicon Supplies Ltd hereby disclaims any and all warranties and liabilities of any kind.

LIFE SUPPORT POLICY: Silicon Supplies Ltd components may be used in life support devices or systems only with the express written approval of Silicon Supplies Ltd, if a failure of such components can reasonably be expected to cause the failure of that life support device or system or to affect the safety or effectiveness of that device or system. Life support devices or systems are intended to be implanted in the human body or to support and/or maintain and sustain and/or protect human life. If they fail, it is reasonable to assume that the health of the user or other persons may be endangered.

