



# Advanced CMOS TTL Input – 74ACT86

Quadruple 2-Input Exclusive OR Gate IC in bare die form

Rev 1.0  
06/02/20

## Description

The 74ACT86 exclusive OR gate (XOR) is fabricated using a 1.5µm advanced CMOS process which combines the high speed performance of LSTTL with CMOS low power consumption. This device contains four independent gates and performs the Boolean functions  $Y = A \oplus B$  or  $Y = \bar{A}B + A\bar{B}$ . Device inputs directly accept LSTTL or CMOS. All inputs are protected against ESD and excess voltage transients.

## Features:

- Inputs directly accept TTL
- Outputs directly interface CMOS, NMOS and TTL
- Outputs Source/Sink 24 mA
- Low Input Current: 1µA
- Functionally compatible with bipolar 74LS86
- Lower power alternative to bipolar logic.

## Ordering Information

The following part suffixes apply:

- No suffix - MIL-STD-883 /2010B Visual Inspection

For High Reliability versions of this product please see

[54ACT86](#)

## Die Dimensions in µm (mils)

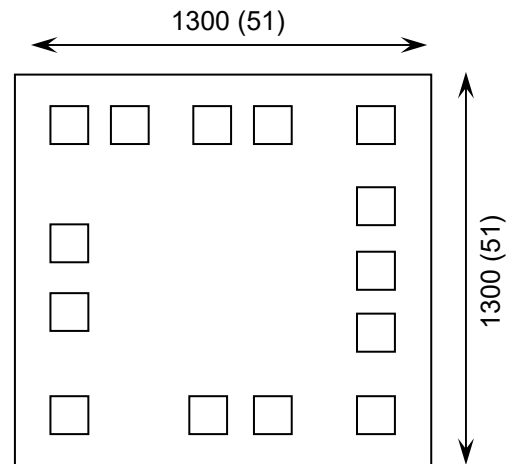

## Supply Formats:

- Default – Die in Waffle Pack (400 per tray capacity)
- ~~Sawn~~ Wafer on Tape – On request
- Unsawn Wafer – On request
- Die Thickness <=> 350µm(14 Mils) – On request
- Assembled into Ceramic Package – On request

## Mechanical Specification

Die Size (Unsawn)	1300 x 1300 51 x 51'	µm mils
Minimum Bond Pad Size	120 x 120 4.72 x 4.72	µm mils
Die Thickness	350 (±20) 13.78 (±0.79)	µm mils
Top Metal Composition	Al 1%Si 1.1µm	
Back Metal Composition	N/A – Bare Si	





# Advanced CMOS TTL Input – 74ACT86

Rev 1.0  
06/02/20

## Pad Layout and Functions

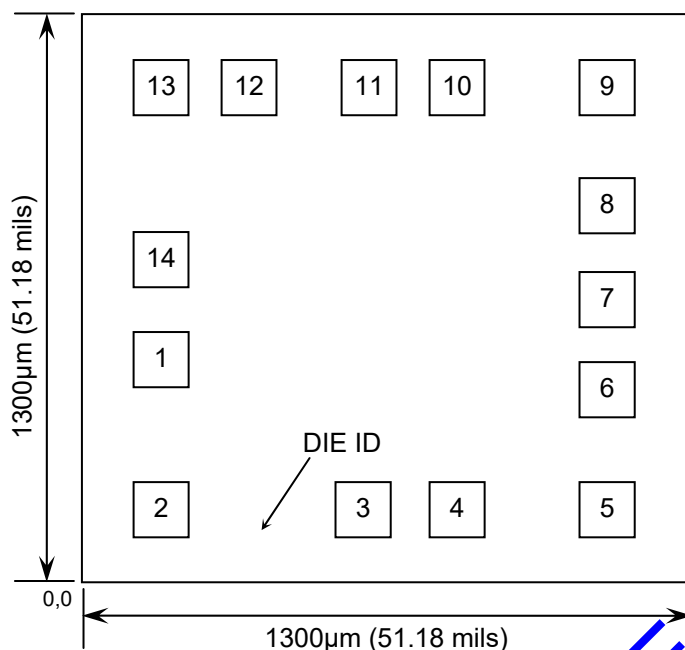

PAD	FUNCTION	COORDINATES (µm)	
		X	Y
1	A1	100	439
2	B1	100	100
3	Y1	547	100
4	A2	751	100
5	B2	1088	100
6	Y2	1088	372
7	GND	1088	579
8	Y3	1088	797
9	A3	1088	1070
10	B3	751	1070
11	Y4	566	1070
12	A4	290	1070
13	B4	100	1070
14	V <sub>CC</sub>	100	671

CONNECT CHIP BACK TO V<sub>CC</sub> OR FLOAT

## Logic Diagram

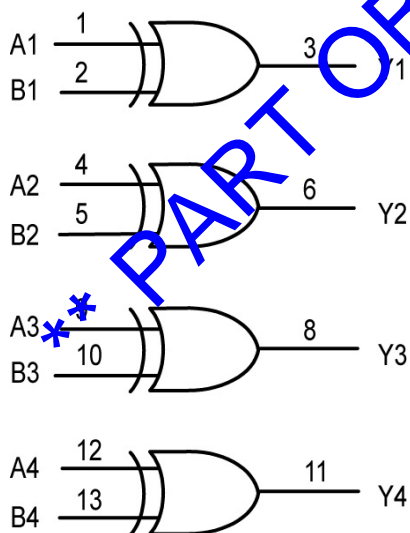

$$Y = A \oplus B$$

$$= \bar{A}B + A\bar{B}$$

## Function Table

INPUTS		OUTPUT
A	B	Y
L	L	L
L	H	H
H	L	H
H	H	L

H = High level (steady state)  
L = Low level (steady state)





# Advanced CMOS TTL Input – 74ACT86

Rev 1.0

06/02/20

## Absolute Maximum Ratings<sup>1</sup>

PARAMETER	SYMBOL	VALUE	UNIT
DC Supply Voltage (Referenced to GND)	$V_{CC}$	-0.5 to +7.0	V
DC Input Voltage (Referenced to GND)	$V_{IN}$	-0.5 to $V_{CC} + 0.5$	V
DC Output Voltage (Referenced to GND)	$V_{OUT}$	-0.5 to $V_{CC} + 0.5$	V
DC Input Current	$I_{IN}$	$\pm 20$	mA
DC Output Current, per pad	$I_{OUT}$	$\pm 50$	mA
DC Supply Current, $V_{CC}$ or GND, per pad	$I_{CC}$	$\pm 50$	mA
Power Dissipation in Still Air <sup>2</sup>	$P_D$	750	mW
Storage Temperature Range	$T_{STG}$	-65 to 150	°C

1. Operation above the absolute maximum rating may cause device failure. Operation at the absolute maximum ratings, for extended periods, may reduce device reliability. 2. Measured in plastic DIP package, results in die form are dependent on die attach and assembly method.

## Recommended Operating Conditions<sup>3</sup> (Voltages Referenced to GND)

PARAMETER	SYMBOL	MIN	MAX	UNITS	
DC Supply Voltage	$V_{CC}$	4.5	5.5	V	
DC Input or Output Voltage	$V_{IN}, V_{OUT}$	0	$V_{CC}$	V	
Operating Temperature Range	$T_J$	-40	+85	°C	
Output current - High	$I_{OH}$	-	-24	mA	
Output current - Low	$I_{OL}$	-	24	mA	
Input Rise or Fall rate ( $V_{IN}$ from 0.8V to 2V)	$\Delta V/\Delta V$	$V_{CC} = 4.5V$	0	10	ns/V
		$V_{CC} = 5.5V$	0	8	

3. This device contains protection circuitry to guard against damage due to high static voltages or electric fields. However, precautions must be taken to avoid applications of any voltage higher than maximum rated voltages to this high-impedance circuit. For proper operation,  $V_{IN}$  and  $V_{OUT}$  should be constrained to the range  $GND \leq (V_{IN} \text{ or } V_{OUT}) \leq V_{CC}$ . Unused inputs must always be tied to an appropriate logic voltage level (e.g., either GND or  $V_{CC}$ ). Unused outputs must be left open.

## DC Electrical Characteristics (Voltages referenced to GND)

PARAMETER	SYMBOL	$V_{CC}$	CONDITIONS	LIMITS			UNITS
				25°C	85°C	FULL RANGE <sup>4</sup>	
Minimum High-Level Input Voltage	$V_{IH}$	4.5V	$V_{OUT} = 0.1V$ or $V_{CC} - 0.1V$	2	2	2	V
		5.5V		2	2	2	
Maximum Low-Level Input Voltage	$V_{IL}$	4.5V	$V_{OUT} = 0.1V$ or $V_{CC} - 0.1V$	0.8	0.8	0.8	V
		5.5V		0.8	0.8	0.8	
Minimum Low-Level Output Voltage	$V_{OL}$	4.5V	$I_{OUT} = 50\mu A$	0.1	0.1	0.1	V
		5.5V		0.1	0.1	0.1	
		4.5V	$V_{IN} = V_{IL}$ or $V_{IH}$ <sup>5</sup>	0.36	0.44	0.44	V
		5.5V	$I_{OL} = 24mA$	0.36	0.44	0.44	
		4.5V	$V_{IN} = V_{IL}$ or $V_{IH}$ <sup>5,6</sup>	-	-	1.65	V
		5.5V	$I_{OL} = 75mA$	-	-	1.65	

4.  $-55^\circ C \leq T_J \leq +125^\circ C$  5. All outputs loaded; thresholds on input associated with output under test. 6. Test time 1sec max, measurement made by forcing indicated current and measuring voltage to minimize power dissipation. Test verifies a minimum 75Ω transmission-line drive capability at 125°C





# Advanced CMOS TTL Input – 74ACT86

Rev 1.0

06/02/20

## DC Electrical Characteristics Continued (Voltages referenced to GND)

PARAMETER	SYMBOL	V <sub>CC</sub>	CONDITIONS	LIMITS			UNITS
				25°C	85°C	FULL RANGE <sup>4</sup>	
Minimum High-Level Output Voltage	V <sub>OH</sub>	4.5V	I <sub>OUT</sub> = 50μA	4.4	4.4	4.4	V
		5.5V		5.4	5.4	5.4	
		4.5V	V <sub>IN</sub> = V <sub>IL</sub> or V <sub>IH</sub> <sup>5</sup> I <sub>OH</sub> = -24mA	3.86	3.76	3.76	V
		5.5V		4.86	4.76	4.76	
Maximum Input Leakage Current	I <sub>IN</sub>	5.5V	V <sub>IN</sub> = V <sub>CC</sub> or GND	±0.1	±1.0	±1.0	μA
Additional Maximum I <sub>CC</sub> / Input	ΔI <sub>CC</sub> T	5.5V	V <sub>IN</sub> = V <sub>CC</sub> - 2.1V	0.6	1.5	1.5	mA
Minimum Dynamic Output Current <sup>7</sup>	I <sub>OLD</sub>	5.5V	V <sub>OLD</sub> = 1.65V Max	-	75	75	mA
	I <sub>OHD</sub>	5.5V	V <sub>OHD</sub> = 3.85V Min	-	-75	-75	
Maximum Quiescent Supply Leakage Current	I <sub>CC</sub>	5.5V	V <sub>IN</sub> = V <sub>CC</sub> or GND I <sub>OUT</sub> = 0μA	4	40	40	μA

7. Maximum test duration 2ms, one output loaded at a time.

## AC Electrical Characteristics<sup>8</sup> V<sub>CC</sub> = 5.0V ±0.5V

PARAMETER	SYMBOL	V <sub>CC</sub>	CONDITIONS	LIMITS			UNITS
				25°C	85°C	FULL RANGE <sup>4</sup>	
Maximum Propagation Delay Input A or B to Output Y (Figure 1)	t <sub>PLH</sub>	5.0V	C <sub>L</sub> = 50pF, Input tr = tf = 3.0ns	9.5	10	10	ns
	t <sub>PHL</sub>	5.0V		9.5	10.5	10.5	
Maximum Input Capacitance	C <sub>IN</sub>	5.0V	T <sub>J</sub> = 25°C	TYPICAL			pF
				4.5			
Power Dissipation Capacitance	C <sub>PD</sub>	5.0V	T <sub>J</sub> = 25°C, C <sub>L</sub> = 50pF	35			pF

8. Not production tested in die form, characterized by chip design.





# Advanced CMOS TTL Input – 74ACT86

Rev 1.0  
06/02/20

## Switching Waveform

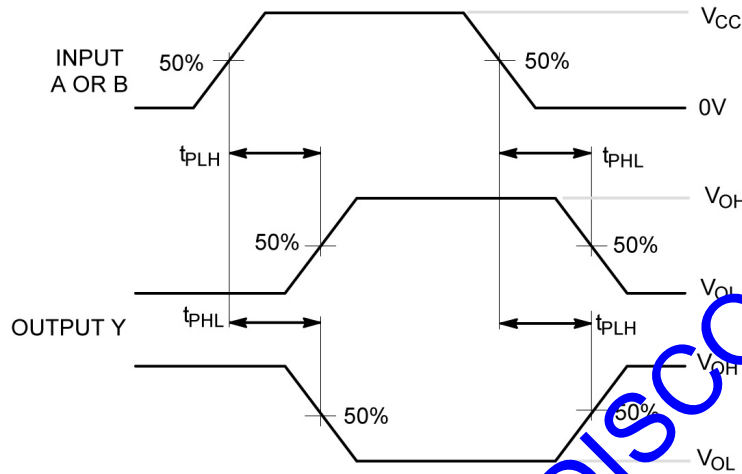
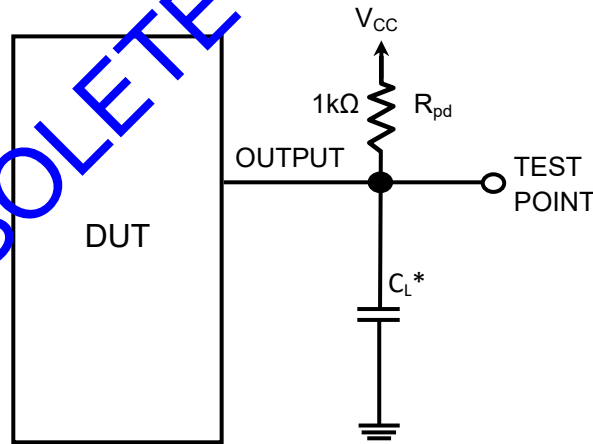

Figure 1 – Propagation Delay

## Test Circuit



\* Includes all probe and jig capacitance

Figure 2

**DISCLAIMER:** The information given in this document shall in no event be regarded as a guarantee of conditions or characteristics. With respect to any examples or hints given herein, any typical values stated herein and/or any information regarding the application of the device, Silicon Supplies Ltd hereby disclaims any and all warranties and liabilities of any kind.

**LIFE SUPPORT POLICY:** Silicon Supplies Ltd components may be used in life support devices or systems only with the express written approval of Silicon Supplies Ltd, if a failure of such components can reasonably be expected to cause the failure of that life support device or system or to affect the safety or effectiveness of that device or system. Life support devices or systems are intended to be implanted in the human body or to support and/or maintain and sustain and/or protect human life. If they fail, it is reasonable to assume that the health of the user or other persons may be endangered.

