



Advanced CMOS Logic – 74AC273

8-bit D-Type Flip-Flop with common reset and clock inputs in bare die form

Rev 1.0
07/12/2021

Description

The 74AC273 consists of eight D-type flip-flops fabricated using a 1.5µm 5V CMOS process combining high speed performance LSTTL performance with CMOS low power consumption. Each flip-flop is equipped with buffered common Clock (CP) and common Reset (\overline{MR}) inputs. A low-to-high clock transition loads each flip-flop. Reset is asynchronous and enabled with active low. Inputs accept standard CMOS outputs or LSTTL outputs using pull-up resistors. Inputs are also equipped with protection circuits against static discharge and transient excess voltage.

Features:

- Buffered common clock
- Buffered asynchronous master reset
- Outputs Source/Sink 24mA
- Low input current: 1µA
- Outputs directly interface CMOS, NMOS and TTL
- Operating voltage range: 2.0V to 6.0V
- Function compatible with 74HC273.

Ordering Information

The following part suffixes apply:

- No suffix - MIL-STD-883 /2010B Visual Inspection

For High Reliability versions of this product please see

[54AC273](#)

Die Dimensions in µm (mils)

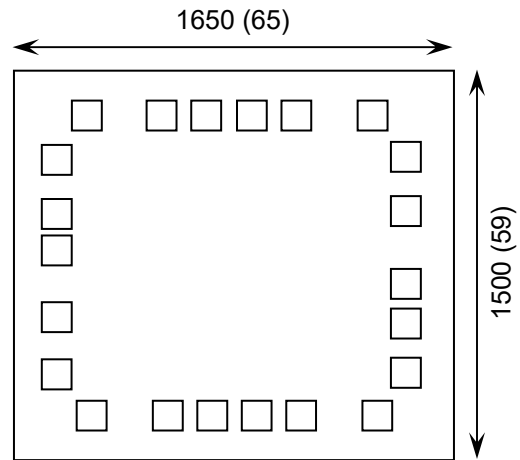

Supply Formats:

- Default – Die in Waffle Pack (100 per tray capacity)
- ~~Sawn~~ Wafer on Tape – On request
- Unsawn Wafer – On request
- Die Thickness <=> 460µm(18 Mils) – On request
- Assembled into Ceramic Package – On request

Mechanical Specification

Die Size (Unsawn)	1650 x 1500 65 x 59	µm mils
Minimum Bond Pad Size	108 x 108 4.25 x 4.25	µm mils
Die Thickness	460 (±20) 18.11 (±0.79)	µm mils
Top Metal Composition	Al 1%Si 1.1µm	
Back Metal Composition	N/A – Bare Si	





Advanced CMOS Logic – 74AC273

Rev 1.0
07/12/2021

Pad Layout and Functions

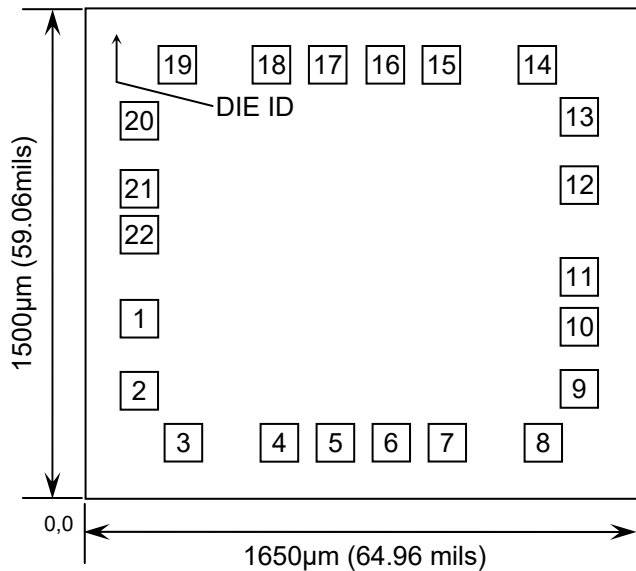

PAD	FUNCTION	COORDINATES (mm)	
		X	Y
1	\overline{MR}	0.120	0.507
2	Q0	0.117	0.286
3	D0	0.247	0.127
4	D1	0.531	0.127
5	Q1	0.699	0.127
6	Q2	0.867	0.127
7	D2	1.035	0.127
8	D3	1.318	0.127
9	Q3	1.426	0.294
10	GND	1.426	0.483
11	GND	1.426	0.570
12	CP	1.428	0.900
13	Q4	1.426	1.120
14	D4	1.299	1.279
15	D5	1.015	1.279
16	Q5	0.847	1.279
17	Q6	0.679	1.279
18	D6	0.511	1.279
19	D7	0.228	1.279
20	Q7	0.117	1.111
21	V _{CC}	0.117	0.903
22	V _{CC}	0.117	0.816

CONNECT CHIP BACK TO V_{CC}

Logic Diagram

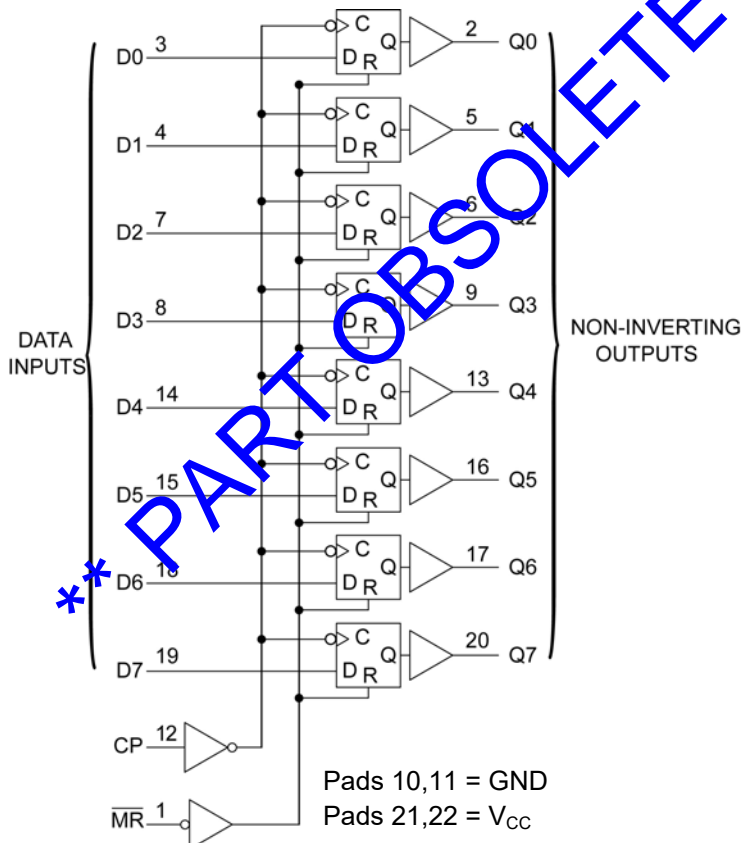

Truth Table

INPUTS			OUTPUT
\overline{MR}	CP	D	Q
L	X	X	L
H		H	H
H		L	L
H	L	X	No Change
H		X	No Change

H = High level (steady state)
L = Low level (steady state)
X = Don't care





Advanced CMOS Logic – 74AC273

Rev 1.0

07/12/2021

Absolute Maximum Ratings¹

PARAMETER	SYMBOL	VALUE	UNIT
DC Supply Voltage (Referenced to GND)	V_{CC}	-0.5 to +7.0	V
DC Input Voltage (Referenced to GND)	V_{IN}	-0.5 to $V_{CC} + 0.5$	V
DC Output Voltage (Referenced to GND)	V_{OUT}	-0.5 to $V_{CC} + 0.5$	V
DC Input Current, per pad	I_{IN}	± 20	mA
DC Output Current, per pad	I_{OUT}	± 50	mA
DC Supply Current, V_{CC} or GND	I_{CC}	± 50	mA
Power Dissipation in Still Air ²	P_D	750	mW
Storage Temperature Range	T_{STG}	-65 to +150	$^{\circ}C$

1. Operation above the absolute maximum rating may cause device failure. Operation at the absolute maximum ratings, for extended periods, may reduce device reliability. 2. Measured in plastic DIP package, results in die form are dependent on die attach and assembly method.

Recommended Operating Conditions³ (Voltages referenced to GND)

PARAMETER	SYMBOL	MIN	MAX	UNITS	
DC Supply Voltage	V_{CC}	2.0	6.0	V	
DC Input or Output Voltage	V_{IN}, V_{OUT}	0	V_{CC}	V	
Operating Temperature Range	T_J	-40	+85	$^{\circ}C$	
Output current - High	I_{OH}	-	-24	mA	
Output current - Low	I_{OL}	-	24	mA	
Input Rise or Fall rate (V_{IN} from 30% to 70% V_{CC})	$\Delta V/\Delta T$	$V_{CC} = 3.0V$	0	150	ns/V
		$V_{CC} = 4.5V$	0	40	
		$V_{CC} = 5.5V$	0	25	

3. This device contains protection circuitry to guard against damage due to high static voltages or electric fields. However, precautions must be taken to avoid applications of any voltage higher than maximum rated voltages to this high-impedance circuit. For proper operation, V_{IN} and V_{OUT} should be constrained to the range $GND \leq (V_{IN} \text{ or } V_{OUT}) \leq V_{CC}$. Unused inputs must always be tied to an appropriate logic voltage level (e.g., either GND or V_{CC}). Unused outputs must be left open.

DC Electrical Characteristics (Voltages referenced to GND)

PARAMETER	SYMBOL	V_{CC}	CONDITIONS	LIMITS			UNITS
				25 $^{\circ}C$	85 $^{\circ}C$	FULL RANGE ⁴	
Minimum High-Level Input Voltage	V_{IH}	3.0V	$V_{OUT} = 0.1V$ or $V_{CC} - 0.1V$	2.1	2.1	2.1	V
		4.5V		3.15	3.15	3.15	
		5.5V		3.85	3.85	3.85	
Maximum Low-Level Input Voltage	V_{IL}	3.0V	$V_{OUT} = 0.1V$ or $V_{CC} - 0.1V$	0.9	0.9	0.9	V
		4.5V		1.35	1.35	1.35	
		5.5V		1.65	1.65	1.65	

4. -40 $^{\circ}C \leq T_J \leq +85^{\circ}C$





Advanced CMOS Logic – 74AC273

Rev 1.0

07/12/2021

DC Electrical Characteristics Continued (Voltages Referenced to GND)

PARAMETER	SYMBOL	V _{CC}	CONDITIONS	LIMITS			UNITS
				25°C	85°C	FULL RANGE ⁴	
Minimum High-Level Output Voltage	V _{OH}	3.0V	I _{OUT} ≤ -50μA	2.9	2.9	2.9	V
		4.5V		4.4	4.4	4.4	
		5.5V		5.4	5.4	5.4	
		3.0V	V _{IN} = V _{IL} or V _{IH} I _{OH} = -12 mA	2.56	2.46	2.46	
		4.5V	V _{IN} = V _{IL} or V _{IH} ⁵ I _{OH} = -24mA ⁵	3.86	3.76	3.76	
		5.5V	V _{IN} = V _{IL} or V _{IH} ⁵ I _{OH} = -24mA ⁵	4.86	4.76	4.76	
		5.5V	V _{IN} = V _{IL} or V _{IH} ⁶ I _{OH} = -75mA ⁶	-	-	3.85	
Maximum Low-Level Output Voltage	V _{OL}	3.0V	I _{OUT} = 50μA	0.1	0.1	0.1	V
		4.5V		0.1	0.1	0.1	
		5.5V		0.1	0.1	0.1	
		3.0V	V _{IN} = V _{IH} or V _{IL} I _{OUT} ≤ 12mA	0.36	0.44	0.44	
		4.5V	V _{IN} = V _{IH} or V _{IL} ⁵ I _{OUT} ≤ 24mA ⁵	0.36	0.44	0.44	
		5.5V	V _{IN} = V _{IH} or V _{IL} ⁵ I _{OUT} ≤ 24mA ⁵	0.36	0.44	0.44	
		5.5V	V _{IN} = V _{IH} or V _{IL} ⁶ I _{OUT} 75mA ⁶	-	-	-	
Maximum Input Leakage Current	I _{IN}	5.5V	V _{IN} = V _{CC} or GND	±0.1	±1.0	±1.0	μA
Minimum Dynamic Output Current ⁷	I _{OLD}	5.5V	V _{OLD} = 1.65V Max	-	75	75	mA
	I _{OHD}	5.5V	V _{OHD} = 3.85V Min	-	-75	-75	
Maximum Quiescent Supply Current	I _{CC}	5.5V	V _{IN} = V _{CC} or GND I _{OUT} = 0μA	8	80	80	μA

5. All outputs loaded; thresholds on input associated with output under test. 6. Test time 1sec max, measurement made by forcing indicated current and measuring voltage to minimize power dissipation. Test verifies a minimum 75Ω transmission-line drive capability at 85°C 7. Maximum test duration 2ms, one output loaded at a time





Advanced CMOS Logic – 74AC273

Rev 1.0

07/12/2021

AC Electrical Characteristics⁸ ($V_{CC} 3.3V \pm 0.3V, V_{CC} 5V \pm 0.3V$)

PARAMETER	SYMBOL	V_{CC}	CONDITIONS	LIMITS			UNITS
				25°C	85°C	FULL RANGE ⁴	
Minimum Clock Frequency (Figure 1)	f_{max}	3.3V	$C_L = 50pF,$ Input $t_r = t_f = 3ns$	90	75	75	MHz
		5.0V		140	125	125	
Maximum Propagation Delay CP to Q (Figure 1)	t_{PLH}	3.3V	$C_L = 50pF,$ Input $t_r = t_f = 3ns$	12.5	14.0	14.0	ns
		5.0V		9.0	10.0	10.0	
	t_{PHL}	3.3V	$C_L = 50pF,$ Input $t_r = t_f = 3ns$	13.0	14.5	14.5	ns
		5.0V		10.0	11.0	11.0	
Maximum Propagation Delay MR to Q (Figure 2)	t_{PLH}	3.3V	$C_L = 50pF,$ Input $t_r = t_f = 3ns$	13.0	14.0	14.0	ns
		5.0V		10.0	10.5	10.5	
	t_{PHL}	3.3V		12.0	14.0	14.0	ns
		5.0V		8.5	10.0	10.0	
Maximum Input Capacitance	C_{IN}	-	-	4.5	4.5	4.5	pF
Power Dissipation Capacitance ⁹	C_{PD}	-	$T_J = 25^\circ C,$ $V_{CC} = 5.0V$	TYPICAL			pF
				50			

8. Not production tested in die form, characterized by chip design.

9. Used to determine the no-load dynamic power consumption: $P_D = C_{PD} V_{CC}^2 f + I_{CC} V_{CC}$.

Timing Requirements⁶ ($V_{CC} 3.3V \pm 0.3V, V_{CC} 5V \pm 0.3V$)

PARAMETER	SYMBOL	V_{CC}	CONDITIONS	LIMITS			UNITS
				25°C	85°C	FULL RANGE ⁴	
Minimum Setup Time, D to CP (Figure 3)	t_{SU}	3.3V	$C_L = 50pF,$ Input $t_r = t_f = 3ns$	5.5	6.0	6.0	ns
		5V		4.0	4.5	4.5	
Minimum Hold Time, D to CP (Figure 3)	t_H	3.3V	$C_L = 50pF,$ Input $t_r = t_f = 3ns$	0	0	0	ns
		5V		1.0	1.0	1.0	
Minimum Pulse Width, CP (Figure 1)	t_w	3.3V	$C_L = 50pF,$ Input $t_r = t_f = 3ns$	5.5	6.0	6.0	ns
		5V		4.0	4.5	4.5	
*Minimum Pulse Width, MR (Figure 2)	t_w	3.3V	$C_L = 50pF,$ Input $t_r = t_f = 3ns$	5.5	6.0	6.0	ns
		5V		4.0	4.5	4.5	
Minimum Recovery Time, MR to CP (Figure 2)	t_{rec}	3.3V	$C_L = 50pF,$ Input $t_r = t_f = 3ns$	3.5	4.5	4.5	ns
		5V		2.0	3.0	3.0	





Advanced CMOS Logic – 74AC273

Rev 1.0
07/12/2021

Switching Waveforms

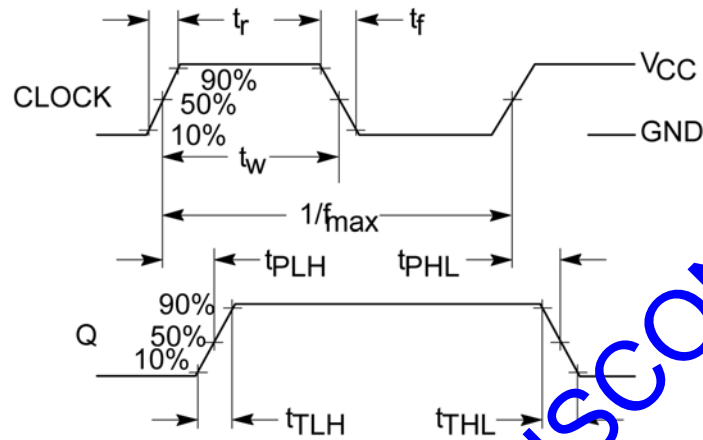

Figure 1 – Propagation Delay & Output Transition Time

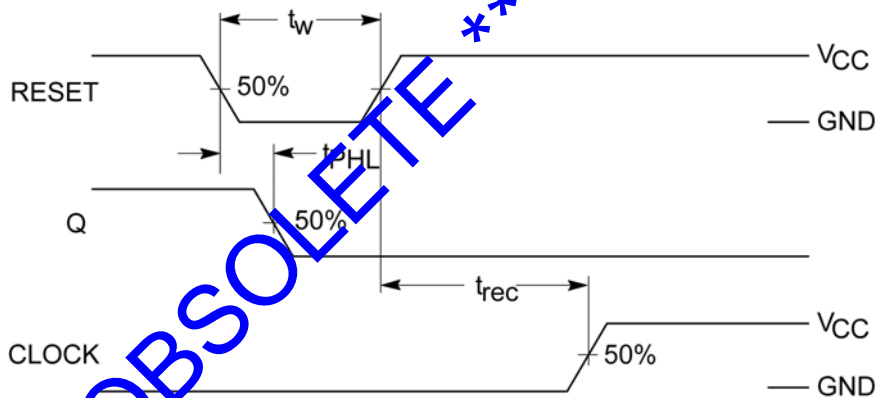

Figure 2 – Propagation Delay – Reset to Q

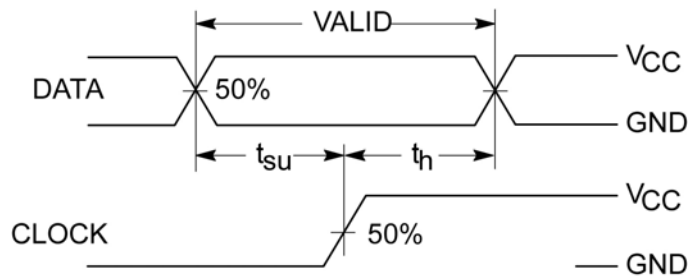
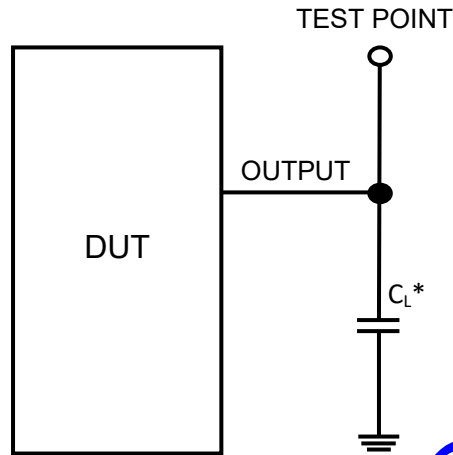

Figure 3 – Timing Requirements





Test Circuit



* Includes all probe and jig capacitance

Figure 4

DISCLAIMER: The information given in this document shall in no event be regarded as a guarantee of conditions or characteristics. With respect to any examples or hints given herein, any typical values stated herein and/or any information regarding the application of the device, Silicon Supplies Ltd hereby disclaims any and all warranties and liabilities of any kind.

LIFE SUPPORT POLICY: Silicon Supplies Ltd components may be used in life support devices or systems only with the express written approval of Silicon Supplies Ltd, if a failure of such components can reasonably be expected to cause the failure of that life support device or system or to affect the safety or effectiveness of that device or system. Life support devices or systems are intended to be implanted in the human body or to support and/or maintain and sustain and/or protect human life. If they fail, it is reasonable to assume that the health of the user or other persons may be endangered.

