



# Low Power Schottky Logic – 54LS138

3-to-8 Line Decoder / Demultiplexer IC in bare die form

Rev 1.0  
21/11/17

## Description

The 54LS138 3-to-8 Line Decoder / Demultiplexer is fabricated on a 2µm 40V Bipolar process. The device decodes 1-of-8 lines, set by x3 binary select inputs & three enable inputs. Multiple Input Enables allow parallel expansion to a 24-line decoder using x3 54LS138 devices or a 32 line decoder using x4 54LS138 + inverter. The LS138 can be used as an 8-output demultiplexer by using one active LOW Enable input as data input & the other Enable inputs as strobes. Unused Enable inputs must be permanently tied to their appropriate active HIGH or active LOW state.

## Features:

- Demultiplexing capability
- Multiple Input Enables for parallel expansion
- Active Low Mutually Exclusive Outputs
- Input Clamp Diodes Limit High Speed Termination Effects
- Full Military Temperature Range.
- Direct drop in replacement for obsolete components in long term programs.

## Ordering Information

The following part suffixes apply:

- No suffix - MIL-STD-883 /2010B Visual Inspection
- "H" - MIL-STD-883 /2010B Visual Inspection + MIL-PRF-38534 Class H LAT
- "K" - MIL-STD-883 /2010A Visual Inspection (Space) + MIL-PRF-38534 Class K LAT

LAT = Lot Acceptance Test.

For further information on LAT process flows see below.

[www.siliconsupplies.com/quality/bare-die-lot-qualification](http://www.siliconsupplies.com/quality/bare-die-lot-qualification)

## Die Dimensions in µm (mils)

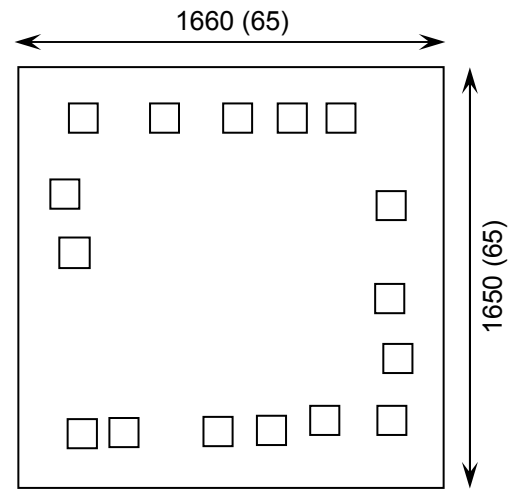

## Supply Formats:

- Default – Die in Waffle Pack (100 per tray capacity)
- Sawn Wafer on Tape – On request
- Unsawn Wafer – On request
- Die Thickness <=> 350µm(14 Mils) – On request
- Assembled into Ceramic Package – On request

## Mechanical Specification

Die Size (Unsawn)	1660 x 1650 65 x 65	µm mils
Minimum Bond Pad Size	116 x 116 4.57 x 4.57	µm mils
Die Thickness	350 (±20) 13.78 (±0.79)	µm mils
Top Metal Composition	Al 1%Si 1.1µm	
Back Metal Composition	N/A – Bare Si	





# Low Power Schottky Logic – 54LS138

Rev 1.0  
21/11/17

## Pad Layout and Functions

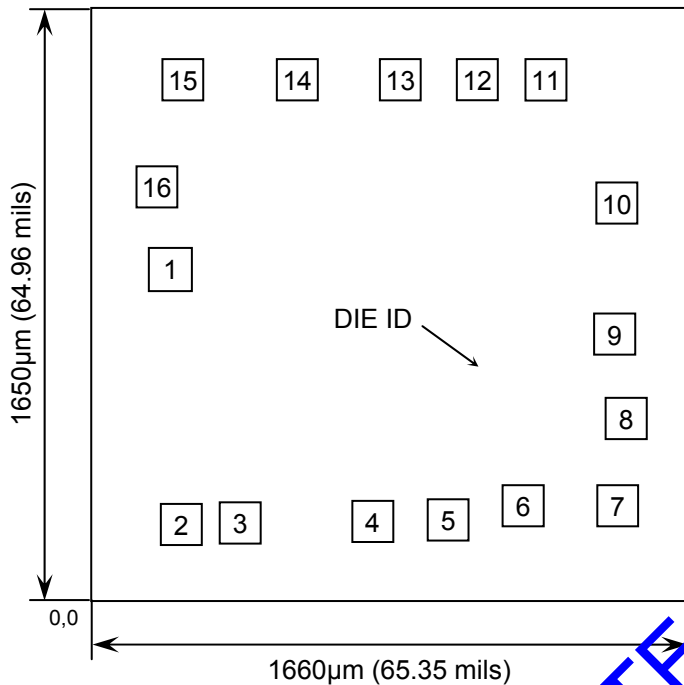

PAD	FUNCTION	COORDINATES (mm)	
		X	Y
1	A	0.173	0.875
2	B	0.197	0.169
3	C	0.361	0.171
4	$\bar{G}2A$	0.725	0.176
5	$\bar{G}2B$	0.929	0.184
6	G1	1.141	0.220
7	Y7	1.405	0.221
8	GND	1.425	0.461
9	Y6	1.393	0.695
10	Y5	1.398	1.054
11	Y4	1.198	1.395
12	Y3	1.022	1.395
13	Y2	0.804	1.395
14	Y1	0.524	1.395
15	Y0	0.202	1.395
16	V <sub>CC</sub>	0.135	1.099

CONNECT CHIP BACK TO GND OR FLOAT

## Truth Table

INPUTS					OUTPUTS								
G1	$\bar{G}2A$	$\bar{G}2B$	C	B	A	Y0	Y1	Y2	Y3	Y4	Y5	Y6	Y7
X	X	H	X	X	X	H	H	H	H	H	H	H	H
X	H	X	X	X	X	H	H	H	H	H	H	H	H
L	X	X	X	X	X	H	H	H	H	H	H	H	H
H	L	L	L	L	L	L	H	H	H	H	H	H	H
H	L	L	L	L	H	H	L	H	H	H	H	H	H
H	L	L	L	H	L	H	H	L	H	H	H	H	H
H	L	L	L	H	H	H	H	L	H	H	H	H	H
H	L	L	H	L	L	H	H	H	H	L	H	H	H
H	L	L	H	L	H	H	H	H	H	H	L	H	H
H	L	L	H	H	L	H	H	H	H	H	H	L	H
H	L	L	H	H	H	H	H	H	H	H	H	H	L

H = High level (steady state)  
L = Low level (steady state)  
X = Don't care





# Low Power Schottky Logic – 54LS138

Rev 1.0  
21/11/17

## Absolute Maximum Ratings<sup>1</sup>

PARAMETER	SYMBOL	VALUE	UNIT
DC Supply Voltage	$V_{CC}$	7.0	V
DC Input Voltage	$V_{IN}$	7.0	V
Storage Temperature Range	$T_{STG}$	-65 to 150	°C

1. Operation above the absolute maximum rating may cause device failure. Operation at the absolute maximum ratings, for extended periods, may reduce device reliability.

## Recommended Operating Conditions

PARAMETER	SYMBOL	MIN	MAX	UNITS
Supply Voltage	$V_{CC}$	4.5	5.5	V
High-Level Input Voltage	$V_{IH}$	2	-	V
Low-Level Input Voltage	$V_{IL}$	-	0.7	V
High-Level Output Current	$I_{OH}$	-	-0.4	mA
Low-Level Output Current	$I_{OL}$	-	4	mA
Operating Temperature Range	$T_J$	-55	+125	°C

## DC Electrical Characteristics<sup>2</sup> $T_J = -55^{\circ}\text{C}$ to $125^{\circ}\text{C}$ unless otherwise specified

PARAMETER	SYMBOL	CONDITIONS	LIMITS			UNITS
			MIN	TYP	MAX	
Minimum High-Level Input Voltage	$V_{IH}$	-	2	-	-	V
Maximum Low-Level Input Voltage	$V_{IL}$	-	-	-	0.7	V
Input Clamp Diode Voltage	$V_{IK}$	$V_{CC} = \text{MIN}$ $I_{IN} = -18\text{mA}$	-	-0.65	-1.5	V
Output Voltage High	$V_{OH}$	$V_{CC} = \text{MIN}, I_{OH} = \text{MAX}$ $V_{IN} = V_{IL}$ or $V_{IH}$ per Function Table	2.5	3.4	-	V
Output Voltage Low	$V_{OL}$	$V_{CC} = \text{MIN}$ $I_{OH} = \text{MAX}$ $V_{IN} = V_{IL}$ or $V_{IH}$ per Truth Table $I_{OL} = 4\text{mA}$	-	0.25	0.4	V
Input High Current	$I_{IH}$	$V_{CC} = \text{MAX}, V_{IN} = 2.7\text{V}$	-	-	20	$\mu\text{A}$
		$V_{CC} = \text{MAX}, V_{IN} = 7.0\text{V}$	-	-	0.1	mA
Input Low Current	$I_{IL}$	$V_{CC} = \text{MAX}, V_{IN} = 0.4\text{V}$	-	-	-0.4	mA
Short Circuit Current <sup>3</sup>	$I_{OS}$	$V_{CC} = \text{MAX}$	-20	-	-100	mA
Power Supply Current (Total)	$I_{CC}$	$V_{CC} = \text{MAX}$	-	6.3	10	mA

2. All typical values @  $V_{CC} = 5\text{V}$ ,  $T_J = 25^{\circ}\text{C}$ . 3. Not more than one output should be shorted at a time, nor for more than 1 second.





# Low Power Schottky Logic – 54LS138

Rev 1.0  
21/11/17

## AC Electrical Characteristics<sup>4</sup>

PARAMETER	SYMBOL	CONDITIONS	DELAY LEVELS	LIMITS			UNITS
				MIN	TYP	MAX	
Propagation Delay, Address to Output	$t_{PLH}$	$V_{CC} = 5V, C_L = 15pF$	2	-	13	20	ns
	$t_{PHL}$		2	-	27	41	
Propagation Delay, Other Input High	$t_{PLH}$	$V_{CC} = 5V, C_L = 15pF$	3	-	18	27	ns
	$t_{PHL}$		3	-	26	39	
Propagation Delay, G2B or G2A Enable to Output	$t_{PLH}$	$V_{CC} = 5V, C_L = 15pF$	2	-	12	18	ns
	$t_{PHL}$		2	-	24	32	
Propagation Delay, G1 Enable to Output	$t_{PLH}$	$V_{CC} = 5V, C_L = 15pF$	3	-	17	26	ns
	$t_{PHL}$		3	-	25	38	

4. Not production tested in die form, characterized by chip design and tested in package.

## Logic Diagram

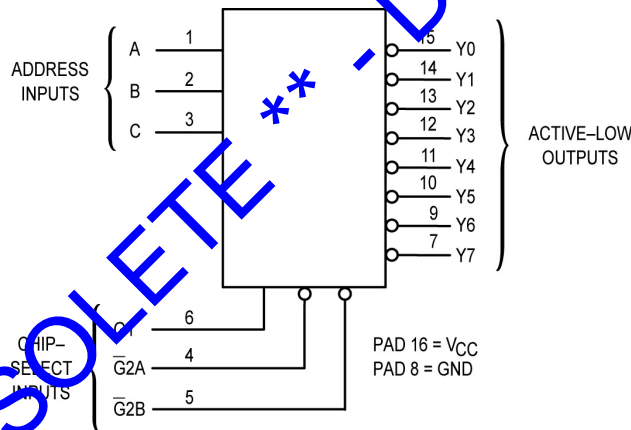

## Switching Waveforms



**DISCLAIMER:** The information given in this document shall in no event be regarded as a guarantee of conditions or characteristics. With respect to any examples or hints given herein, any typical values stated herein and/or any information regarding the application of the device, Silicon Supplies Ltd hereby disclaims any and all warranties and liabilities of any kind.

**LIFE SUPPORT POLICY:** Silicon Supplies Ltd components may be used in life support devices or systems only with the express written approval of Silicon Supplies Ltd, if a failure of such components can reasonably be expected to cause the failure of that life support device or system or to affect the safety or effectiveness of that device or system. Life support devices or systems are intended to be implanted in the human body or to support and/or maintain and sustain and/or protect human life. If they fail, it is reasonable to assume that the health of the user or other persons may be endangered.

