



High Speed CMOS Logic – 54HC20

Dual 4-Input NAND Gate IC in bare die form

Rev 1.0
7/5/2019

Description

The 54HC20 Dual 4-Input NAND Gate is made using a 2.5µm 5V CMOS process & combines the high speed of LSTTL with CMOS low power consumption. The device performs Boolean functions $Y = (A \cdot B \cdot C \cdot D)$ or $Y = \overline{A + B + C + D}$ in positive logic. Inputs accept standard CMOS outputs or LSTTL outputs using pull-up resistors. Internal circuitry comprises 3 stages & includes buffered output for high noise immunity & stability. Inputs are equipped with protection circuits against static discharge & transient excess voltage.

Features:

- High Speed: $t_{PD} = 11ns @ 6V$ (Typ.)
- Low Input Current: 1µA
- Output Drive Capability: 10 LSTTL loads
- Operating Voltage Range: 2V to 6V
- CMOS High Noise Immunity
- Function compatible with 54LS20
- Full Military Temperature Range.

Ordering Information

The following part suffixes apply:

- No suffix - MIL-STD-883 /2010B Visual Inspection
- "H" - MIL-STD-883 /2010B Visual Inspection + MIL-PRF-38534 Class H LAT
- "K" - MIL-STD-883 /2010A Visual Inspection (Space) + MIL-PRF-38534 Class K LAT

LAT = Lot Acceptance Test.

For further information on LAT process flows see below.

www.siliconsupplies.com/quality/bare-die-lot-qualification

Die Dimensions in µm (mils)

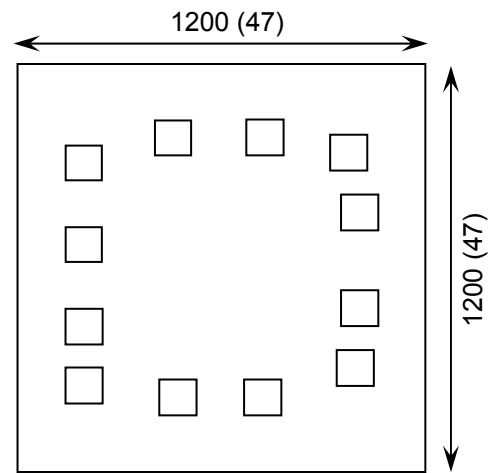

Supply Formats:

- Default – Die in Waffle Pack (400 per tray capacity)
- Sawn Wafer on Tape – On request
- Unsawn Wafer – On request
- Die Thickness <=> 350µm(14 Mils) – On request
- Assembled into Ceramic Package – On request

Mechanical Specification

Die Size (Unsawn)	1200 x 1200 47 x 47	µm mils
Minimum Bond Pad Size	106 x 106 4 x 4	µm mils
Die Thickness	350 (±20) 13.78 (±0.79)	µm mils
Top Metal Composition	Al 1%Si 1.1µm	
Back Metal Composition	N/A – Bare Si	





High Speed CMOS Logic – 54HC20

Rev 1.0
7/5/2019

Pad Layout and Functions

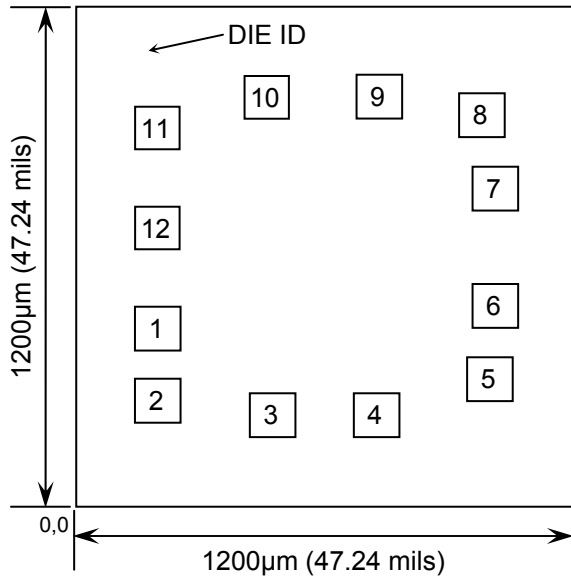

PAD	FUNCTION	COORDINATES (mm)	
		X	Y
1	1A	0.151	0.364
2	1B	0.151	0.184
3	1C	0.427	0.151
4	1D	0.671	0.151
5	1Y	0.933	0.238
6	GND	0.943	0.418
7	2Y	0.943	0.706
8	2A	0.909	0.886
9	2B	0.672	0.929
10	2C	0.405	0.917
11	2D	0.151	0.853
12	V _{CC}	0.151	0.608

CONNECT CHIP BACK TO V_{CC} OR FLOAT

Logic Diagram

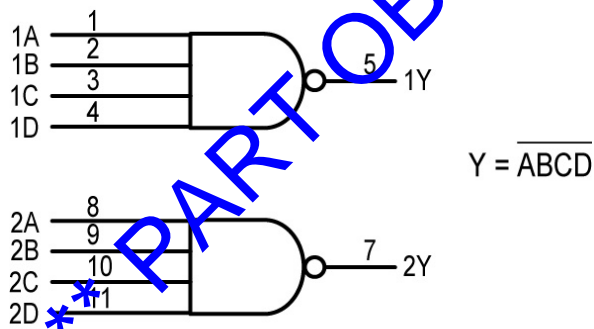

Pad 12 = V_{CC}
Pad 6 = GND

Function Table

INPUTS				OUTPUT
A	B	C	D	Y
L	X	X	X	H
X	L	X	X	H
X	X	L	X	H
X	X	X	L	H
H	H	H	H	L

H = High level (steady state)
L = Low level (steady state)
X = don't care





High Speed CMOS Logic – 54HC20

Rev 1.0
7/5/2019

Absolute Maximum Ratings¹

PARAMETER	SYMBOL	VALUE	UNITS
Supply Voltage (Referenced to GND)	V_{CC}	-0.5 to +7.0	V
DC Input Voltage (Referenced to GND)	V_{IN}	-1.5 to $V_{CC} + 1.5$	V
DC Output Voltage (Referenced to GND)	V_{OUT}	-0.5 to $V_{CC} + 0.5$	V
DC Input Current, per pad	I_{IN}	± 20	mA
DC Output Current, per pad	I_{OUT}	± 25	mA
DC Supply Current, V_{CC} or GND, per pad	I_{CC}	± 50	mA
Power Dissipation in Still Air ²	P_D	750	mW
Storage Temperature Range	T_{STG}	-65 to 150	$^{\circ}C$

1. Operation above the absolute maximum rating may cause device failure. Operation at the absolute maximum ratings, for extended periods, may reduce device reliability. 2. Measured in plastic DIP package, results in die form are dependent on die attach and assembly method.

Recommended Operating Conditions³ (Voltages referenced to GND)

PARAMETER	SYMBOL	MIN	MAX	UNITS	
Supply Voltage	V_{CC}	2	6	V	
DC Input or Output Voltage	V_{IN}, V_{OUT}	0	V_{CC}	V	
Operating Temperature Range	T_J	-55	+125	$^{\circ}C$	
Input Rise or Fall Times	t_r, t_f	$V_{CC} = 2.0V$	0	1000	ns
		$V_{CC} = 4.5V$	0	500	
		$V_{CC} = 6V$	0	400	

3. This device contains protection circuitry to guard against damage due to high static voltages or electric fields. However, precautions must be taken to avoid applications of any voltage higher than maximum rated voltages to this high-impedance circuit. For proper operation, V_{IN} and V_{OUT} should be constrained to the range $GND \leq (V_{IN} \text{ or } V_{OUT}) \leq V_{CC}$. Unused inputs must always be tied to an appropriate logic voltage level (e.g., either GND or V_{CC}). Unused outputs must be left open.

DC Electrical Characteristics (Voltages referenced to GND)

PARAMETER	SYMBOL	V_{CC}	CONDITIONS	LIMITS			UNITS
				25 $^{\circ}C$	85 $^{\circ}C$	FULL RANGE ⁴	
Minimum High-Level Input Voltage	V_{IH}	2V	$V_{OUT} = 0.1V$ or $V_{CC} - 0.1V$ $ I_{OUT} \leq 20\mu A$	1.5	1.5	1.5	V
		4.5V		3.15	3.15	3.15	
		6.0V		4.2	4.2	4.2	
Maximum Low-Level Input Voltage	V_{IL}	2V	$V_{OUT} = 0.1V$ or $V_{CC} - 0.1V$ $ I_{OUT} \leq 20\mu A$	0.3	0.3	0.3	V
		4.5V		0.9	0.9	0.9	
		6.0V		1.2	1.2	1.2	

4. -55 $^{\circ}C \leq T_J \leq +125^{\circ}C$





High Speed CMOS Logic – 54HC20

Rev 1.0

7/5/2019

DC Electrical Characteristics Continued (Voltages referenced to GND)

PARAMETER	SYMBOL	V _{CC}	CONDITIONS	LIMITS			UNITS
				25°C	85°C	FULL RANGE ⁴	
Minimum High-Level Output Voltage	V _{OH}	2V	V _{IN} = V _{IH} or V _{IL} I _{OUT} ≤ 20μA	1.9	1.9	1.9	V
		4.5V		4.4	4.4	4.4	
		6.0V		5.9	5.9	5.9	
		4.5V	V _{IN} = V _{IH} or V _{IL} I _{OUT} ≤ 4.0mA	3.98	3.84	3.70	V
		6.0V		5.48	5.34	5.20	
Maximum Low-Level Output Voltage	V _{OL}	2V	V _{IN} = V _{IH} or V _{IL} I _{OUT} ≤ 20μA	0.1	0.1	0.1	V
		4.5V		0.1	0.1	0.1	
		6.0V		0.1	0.1	0.1	
		4.5V	V _{IN} = V _{IH} or V _{IL} I _{OUT} ≤ 4.0mA	0.26	0.33	0.40	V
		6.0V		0.26	0.33	0.40	
Maximum Input Leakage Current	I _{IN}	6.0V	V _{IN} = V _{CC} or GND	±0.1	±1.0	±1.0	μA
Maximum Quiescent Supply Current	I _{CC}	6.0V	V _{IN} = V _{CC} or GND, I _{OUT} = 0μA	2	20	40	μA

AC Electrical Characteristics⁵

PARAMETER	SYMBOL	V _{CC}	CONDITIONS	LIMITS			UNITS
				25°C	85°C	FULL RANGE ⁴	
Maximum Propagation Delay, Input A, B, C, D to Output Y	t _{PLH} , t _{PHL}	2V	C _L = 50pF, t _r = t _f = 6ns	90	115	135	ns
		4.5V		18	23	27	
		6.0V		15	20	23	
Maximum Output Rise and Fall Time, Any Output	t _{TLH} , t _{THL}	2V	C _L = 50pF, t _r = t _f = 6ns	75	95	110	ns
		4.5V		15	19	22	
		6.0V		13	16	19	
*Maximum Input Capacitance	C _{IN}	-	-	10	10	10	pF
Power Dissipation Capacitance Per Gate ⁶	C _{PD}	-	T _J = 25°C, V _{CC} = 5.0V	TYPICAL			pF
				26			

5. Not production tested in die form, characterized by chip design and tested in package.

6. Used to determine the no-load dynamic power consumption: P_D = C_{PD} V_{CC}²f + I_{CC} V_{CC}.





High Speed CMOS Logic – 54HC20

Rev 1.0
7/5/2019

Switching Waveform

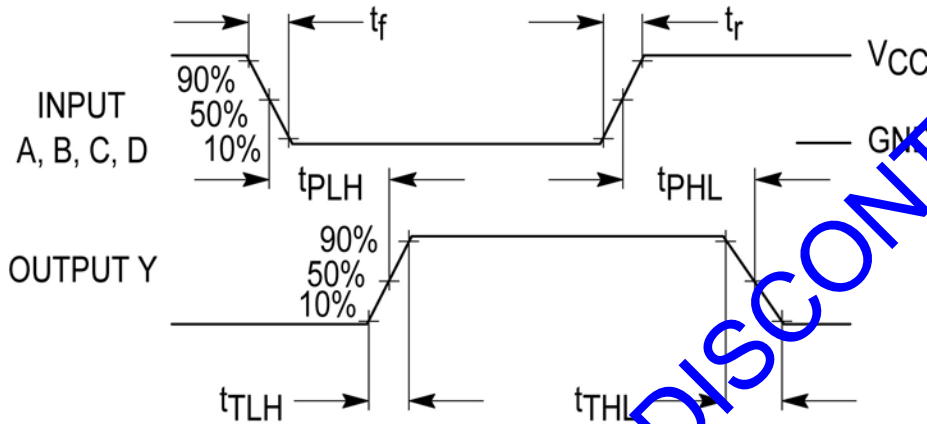

Test Circuit

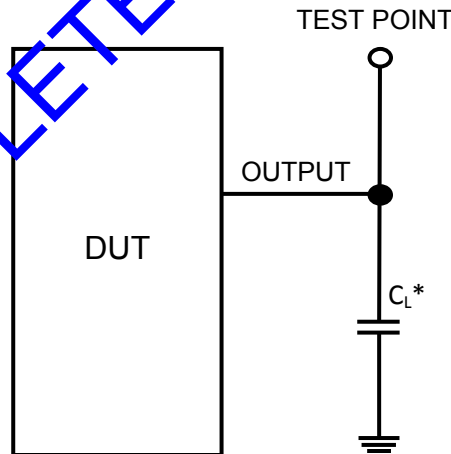

* Includes all probe and jig capacitance

DISCLAIMER: The information given in this document shall in no event be regarded as a guarantee of conditions or characteristics. With respect to any examples or hints given herein, any typical values stated herein and/or any information regarding the application of the device, Silicon Supplies Ltd hereby disclaims any and all warranties and liabilities of any kind.

LIFE SUPPORT POLICY: Silicon Supplies Ltd components may be used in life support devices or systems only with the express written approval of Silicon Supplies Ltd, if a failure of such components can reasonably be expected to cause the failure of that life support device or system or to affect the safety or effectiveness of that device or system. Life support devices or systems are intended to be implanted in the human body or to support and/or maintain and sustain and/or protect human life. If they fail, it is reasonable to assume that the health of the user or other persons may be endangered.

