



High Speed CMOS Logic – 54HC175

Quad D-Type Flip-Flop Logic IC with Reset in bare die form

Rev 1.0
21/11/17

Description

The 54HC175 is fabricated using a 2.5µm 5V CMOS process and consists of four D-Type flip-flops each with separate D input and common Reset and Clock inputs. The logic level present at the “D” input is transferred to the Q output during the positive-going transition of the clock pulse. Reset is clock independent and is accomplished by a low level on the Reset line. The device is useful for applications where both the true and complement outputs are required and the clock and master reset are common to all storage elements.

Features:

- Output Drive Capability: 10 LSTTL Loads
- Outputs Directly Interface to CMOS, NMOS, and TTL
- Low Input Current: 1µA
- High Noise Immunity Characteristics of CMOS
- Operating Voltage Range: 2.0 to 6.0 V
- Direct drop-in replacement for obsolete components in long term programs.

Ordering Information

The following part suffixes apply:

- No suffix - MIL-STD-883 /2010B Visual Inspection
- “H” - MIL-STD-883 /2010B Visual Inspection + MIL-PRF-38534 Class H LAT
- “K” - MIL-STD-883 /2010A Visual Inspection (Space) + MIL-PRF-38534 Class K LAT

LAT = Lot Acceptance Test.

For further information on LAT process flows see below.

www.siliconsupplies.com/quality/bare-die-lot-qualification

Die Dimensions in µm (mils)

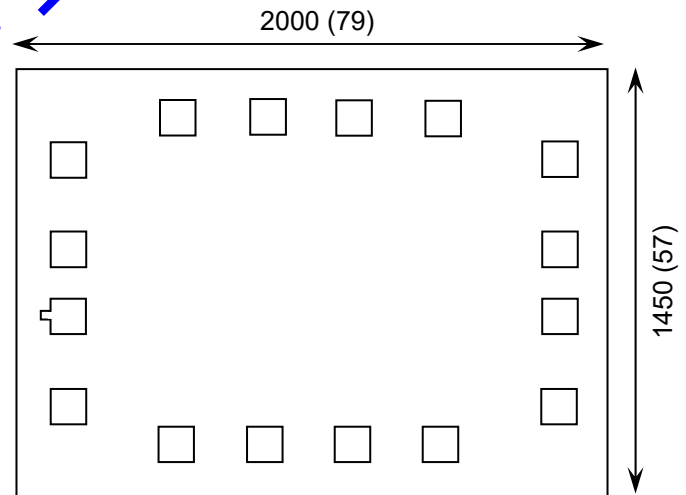

Supply Formats:

- Default – Die in Waffle Pack (100 per tray capacity)
- ~~Sawn Wafer on Tape – On request~~
- Unsawn Wafer – On request
- Die Thickness <=> 350µm(14 Mils) – On request
- Assembled into Ceramic Package – On request

Mechanical Specification

Die Size (Unsawn)	2000 x 1450 79 x 57	µm mils
Minimum Bond Pad Size	120 x 120 4.72 x 4.72	µm mils
Die Thickness	350 (±20) 13.78 (±0.79)	µm mils
Top Metal Composition	Al 1%Si 1.1µm	
Back Metal Composition	N/A – Bare Si	





High Speed CMOS Logic – 54HC175

Rev 1.0
21/11/17

Pad Layout and Functions

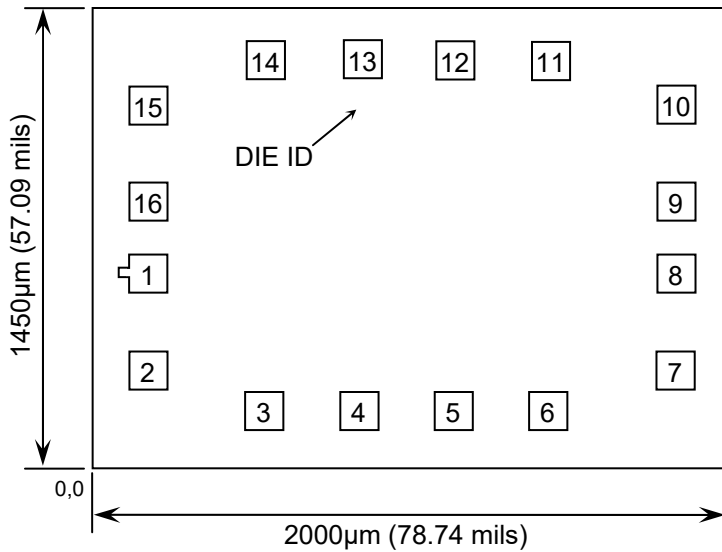

PAD	FUNCTION	COORDINATES (mm)	
		X	Y
1	RESET	0.122	0.554
2	Q0	0.122	0.251
3	$\overline{Q0}$	0.480	0.122
4	D0	0.780	0.122
5	D1	1.070	0.122
6	$\overline{Q1}$	1.370	0.122
7	Q1	1.771	0.251
8	GND	1.771	0.554
9	CLOCK	1.771	0.781
10	Q2	1.771	1.084
11	$\overline{Q2}$	1.373	1.222
12	D2	1.073	1.222
13	D3	0.783	1.222
14	$\overline{Q3}$	0.483	1.222
15	Q3	0.122	1.084
16	V _{CC}	0.122	0.781

CONNECT CHIP BACK TO V_{CC} OR FLOAT

Logic Diagram

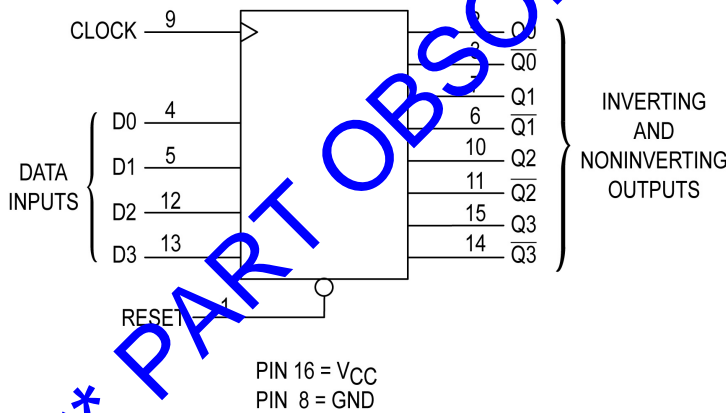

Truth Table

INPUTS			OUTPUTS	
RESET	CLOCK	D	Q	\overline{Q}
L	X	X	L	H
H	\nearrow	H	H	L
H	\searrow	L	L	H
H	L	X	No Change	





High Speed CMOS Logic – 54HC175

Rev 1.0

21/11/17

Absolute Maximum Ratings¹

PARAMETER	SYMBOL	VALUE	UNIT
DC Supply Voltage (Referenced to GND)	V_{CC}	-0.5 to +7.0	V
DC Input Voltage (Referenced to GND)	V_{IN}	-1.5 to $V_{CC}+1.5$	V
DC Output Voltage (Referenced to GND)	V_{OUT}	-0.5 to $V_{CC}+0.5$	V
Storage Temperature Range	T_{STG}	-65 to 150	°C
Input Current (per Pad)	I_{IN}	±20	mA
Output Current (per Pad)	I_{OUT}	±25	mA
DC Supply Current, V_{CC} or GND, per pad	I_{CC}	±50	mA
Power Dissipation in Still Air ²	P_D	50	mW

1. Operation above the absolute maximum rating may cause device failure. Operation at the absolute maximum ratings, for extended periods, may reduce device reliability. 2. Measured in plastic DIP package, results in die form are dependent on die attach and assembly method.

Recommended Operating Conditions³ (Voltages referenced to GND)

PARAMETER	SYMBOL	MIN	MAX	UNITS
Supply Voltage	V_{CC}	2.0	6.0	V
DC Input Voltage, Output Voltage	V_{IN}, V_{OUT}	0	V_{CC}	V
Operating Temperature Range	T_J	-55	+125	°C
Input Rise / Fall Time	$V_{CC}=2.0V$	0	1000	ns
	$V_{CC}=4.5V$	0	500	
	$V_{CC}=6.0V$	0	400	

3. This device contains protection circuitry against damage due to high static voltages or electric fields. However, precautions must be taken to avoid applications of voltage higher than max rated voltages to this high-impedance circuit. For proper operation, V_{IN} and V_{OUT} should be constrained to range $GND \leq (V_{IN} \text{ or } V_{OUT}) \leq V_{CC}$. Unused inputs must be tied to an appropriate logic voltage level (e.g., GND or V_{CC}). Unused outputs must be left open.

DC Electrical Characteristics (Voltages referenced to GND)

PARAMETER	SYMBOL	V_{CC}	CONDITIONS	LIMITS			UNITS
				25°C	85°C	FULL RANGE ⁴	
Minimum High-Level Input Voltage	V_{IH}	2.0	$V_{OUT} = 0.1V$ or $V_{CC} - 0.1V$ $ I_{OUT} \leq 20\mu A$	1.5	1.5	1.5	V
		4.5		3.15	3.15	3.15	
		6.0		4.2	4.2	4.2	
Maximum Low-Level Input Voltage	V_{IL}	2.0	$V_{OUT} = 0.1V$ or $V_{CC} - 0.1V$ $ I_{OUT} \leq 20\mu A$	0.3	0.3	0.3	V
		4.5		0.9	0.9	0.9	
		6.0		1.2	1.2	1.2	
Minimum High-Level Output Voltage	V_{OH}	2.0	$V_{IN} = V_{IH} \text{ or } V_{IL}$ $ I_{OUT} \leq 20\mu A$	1.9	1.9	1.9	V
		4.5		4.4	4.4	4.4	
		6.0		5.9	5.9	5.9	
		4.5	$V_{IN} = V_{IH} \text{ or } V_{IL}$ $ I_{OUT} \leq 4.0mA$	3.98	3.84	3.7	V
		6.0	$V_{IN} = V_{IH} \text{ or } V_{IL}$ $ I_{OUT} \leq 5.2mA$	5.48	5.34	5.2	V





High Speed CMOS Logic – 54HC175

Rev 1.0

21/11/17

DC Electrical Characteristics Continued (Voltages referenced to GND)

PARAMETER	SYMBOL	V _{CC}	CONDITIONS	LIMITS			UNITS
				25°C	85°C	FULL RANGE ⁴	
Maximum Low-Level Output Voltage	V _{OL}	2.0	V _{IN} = V _{IH} or V _{IL} I _{OUT} ≤ 20μA	0.1	0.1	0.1	V
		4.5		0.1	0.1	0.1	
		6.0		0.1	0.1	0.1	
		4.5	V _{IN} = V _{IH} or V _{IL} I _{OUT} ≤ 4.0mA	0.26	0.33	0.4	V
		6.0		V _{IN} = V _{IH} or V _{IL} I _{OUT} ≤ 5.2mA	0.26	0.33	
Maximum Input Leakage Current	I _{IN}	6.0	V _{IN} = GND or V _{CC}	±0.1	±1.0	±1.0	μA
Maximum Quiescent Supply Current	I _{CC}	6.0	V _{IN} = GND or V _{DD} I _{OUT} = 0μA	8	80	160	μA

4. -55°C ≤ T_J ≤ +125°C

AC Electrical Characteristics⁵

PARAMETER	SYMBOL	V _{CC}	CONDITIONS	LIMITS			UNITS
				25°C	85°C	FULL RANGE ⁴	
Maximum Clock Frequency (Figure 1, 4)	f _{max}	2.0	C _L = 50pF, t _r = t _f = 6ns	6.0	4.8	4.0	MHz
		4.5		30	24	20	
		6.0		35	28	24	
Propagation Delay, Clock to Q or Q̄ (Figure 1, 4)	t _{PLH} , t _{PHL}	2.0	C _L = 50pF, t _r = t _f = 6ns	150	190	225	ns
		4.5		30	38	45	
		6.0		26	33	38	
Propagation Delay, Reset to Q or Q̄ (Figure 2, 4)	t _{PLH} , t _{PHL}	2.0	C _L = 50pF, t _r = t _f = 6ns	125	155	190	ns
		4.5		25	31	38	
		6.0		21	26	32	
Output Transition Time, Any Output (Figure 1, 4)	t _{TLH} , t _{THL}	2.0	C _L = 50pF, t _r = t _f = 6ns	75	95	110	ns
		4.5		15	19	22	
		6.0		13	16	19	
Input Capacitance	C _{IN}	-	C _L = 50pF, t _r = t _f = 6ns	10	10	10	pF
Power Dissipation Capacitance (Per Flip-Flop)	C _{PD}	-	T _J = 25°C, V _{CC} = 5.0V	TYPICAL			pF
				35			

5. Not production tested in die form, characterized by chip design and tested in package.





High Speed CMOS Logic – 54HC175

Rev 1.0
21/11/17

Timing Requirements⁵

PARAMETER	SYMBOL	V _{CC}	CONDITIONS	LIMITS			UNITS
				25°C	85°C	FULL RANGE ⁴	
Minimum Setup Time, Data to Clock (Figure 3)	t _{su}	2.0	C _L = 50pF, t _r = t _f = 6ns	100	125	150	ns
		4.5		20	25	30	
		6.0		17	21	26	
Minimum Hold Time, Clock to Data (Figure 3)	t _h	2.0	C _L = 50pF, t _r = t _f = 6ns	3.0	3.0	3.0	ns
		4.5		3.0	3.0	3.0	
		6.0		3.0	3.0	3.0	
Minimum Recovery Time, Reset Inactive to Clock (Figure 2)	t _{rec}	2.0	C _L = 50pF, t _r = t _f = 6ns	100	125	150	ns
		4.5		20	25	30	
		6.0		17	21	26	
Minimum Pulse Width, Clock (Figure 1)	t _w	2.0	C _L = 50pF, t _r = t _f = 6ns	80	100	120	ns
		4.5		16	20	24	
		6.0		14	17	20	
Minimum Pulse Width, Reset (Figure 2)	t _w	2.0	C _L = 50pF, t _r = t _f = 6ns	80	100	120	ns
		4.5		16	20	24	
		6.0		14	17	20	
Maximum Input Rise and Fall Times (Figure 1)	t _r , t _f	2.0	C _L = 50pF, t _r = t _f = 6ns	1000	1000	1000	ns
		4.5		500	500	500	
		6.0		400	400	400	

5. Not production tested in die form, characterized by chip design and tested in package.

Switching Waveforms

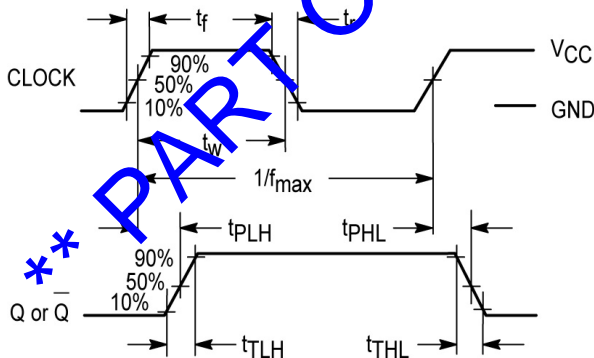

Figure 1 – Data, Clock and Output

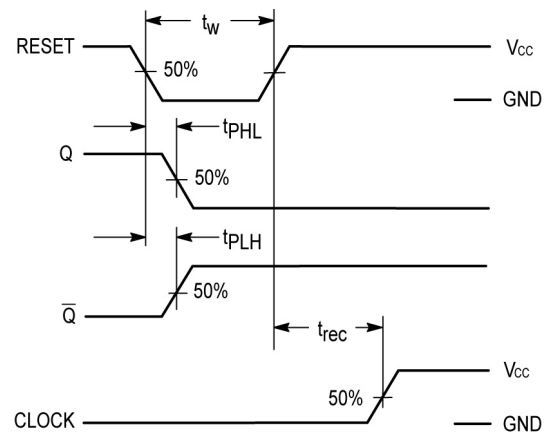

Figure 2 – Reset, Clock and Output





High Speed CMOS Logic – 54HC175

Rev 1.0
21/11/17

Switching Waveforms continued

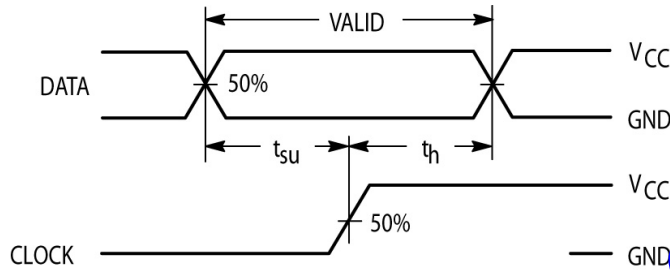
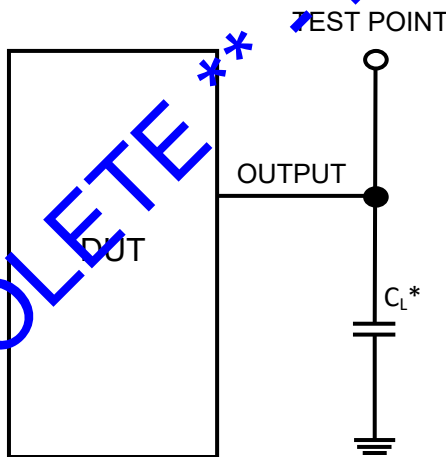

Figure 3 – Clock to Data



* Includes all probe and jig capacitance

Figure 4 – Test Circuit

DISCLAIMER: The information given in this document shall in no event be regarded as a guarantee of conditions or characteristics. With respect to any examples or hints given herein, any typical values stated herein and/or any information regarding the application of the device, Silicon Supplies Ltd hereby disclaims any and all warranties and liabilities of any kind.

LIFE SUPPORT POLICY: Silicon Supplies Ltd components may be used in life support devices or systems only with the express written approval of Silicon Supplies Ltd, if a failure of such components can reasonably be expected to cause the failure of that life support device or system or to affect the safety or effectiveness of that device or system. Life support devices or systems are intended to be implanted in the human body or to support and/or maintain and sustain and/or protect human life. If they fail, it is reasonable to assume that the health of the user or other persons may be endangered.

