



High Speed CMOS Logic – 54HC109

Dual J-K Flip-flop with Set and Reset in bare die form

Rev 1.0
16/4/18

Description

The 54HC109 is fabricated using a 2.5µm 5V CMOS process and has the same high speed performance of LSTTL combined with CMOS low power consumption. The J and K logic level at positive clock edge changes the devices output state. Set and Reset functions are asynchronous, operating independently of the clock and executed by a logic low on the corresponding input. Schmitt-trigger action in the clock input makes the circuit highly tolerant to slower clock rise and fall times.

Features:

- Output Drive Capability: 10 LSTTL Loads
- Low Input Current: 1µA
- Outputs directly interface CMOS, NMOS and TTL
- Operating Voltage Range: 2V to 6V
- CMOS High Noise Immunity
- Function compatible with 54LS109
- Full Military Temperature Range.

Ordering Information

The following part suffixes apply:

- No suffix - MIL-STD-883 /2010B Visual Inspection
- "H" - MIL-STD-883 /2010B Visual Inspection + MIL-PRF-38534 Class H LAT
- "K" - MIL-STD-883 /2010A Visual Inspection (Space) + MIL-PRF-38534 Class K LAT

LAT = Lot Acceptance Test.

For further information on LAT process flows see below.

www.siliconsupplies.com/quality/bare-die-lot-qualification

Die Dimensions in µm (mils)

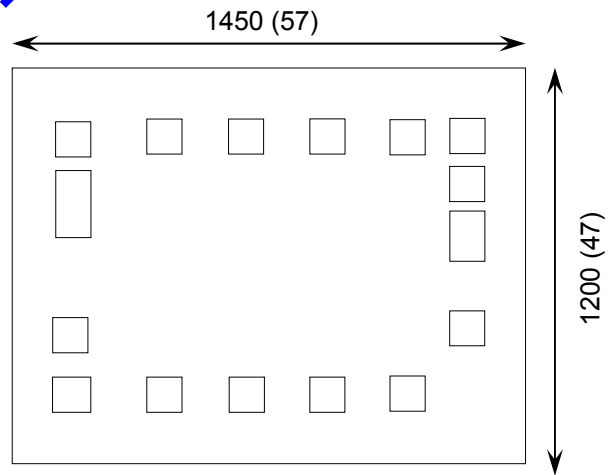

Supply Formats:

- Default – Die in Waffle Pack (400 per tray capacity)
- Sawn Wafer on Tape – On request
- Unsawn Wafer – On request
- Die Thickness <=> 350µm(14 Mils) – On request
- Assembled into Ceramic Package – On request

Mechanical Specification

Die Size (Unsawn)	1450 x 1200 57 x 47	µm mils
Minimum Bond Pad Size	106 x 106 4.17 x 4.17	µm mils
Die Thickness	350 (±20) 13.78 (±0.79)	µm mils
Top Metal Composition	Al 1%Si 1.1µm	
Back Metal Composition	N/A – Bare Si	





High Speed CMOS Logic – 54HC109

Rev 1.0

16/4/18

Pad Layout and Functions

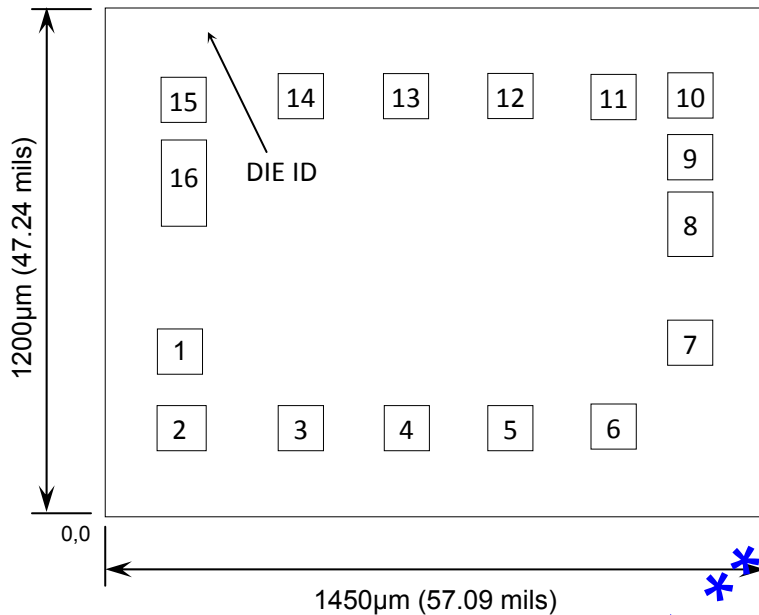

PAD	FUNCTION	COORDINATES (mm)	
		X	Y
1	RESET 1	0.130	0.375
2	J1	0.140	0.135
3	$\overline{K1}$	0.395	0.145
4	CLOCK 1	0.625	0.145
5	SET 1	0.850	0.145
6	Q1	1.035	0.165
7	$\overline{Q1}$	1.220	0.420
8	GND	1.230	0.700
9	$\overline{Q2}$	1.230	0.890
10	Q2	1.220	0.935
11	SET 2	1.045	0.935
12	CLOCK 2	0.815	0.935
13	$\overline{K2}$	0.585	0.935
14	J2	0.360	0.935
15	RESET 2	0.130	0.900
16	V _{CC}	0.120	0.605

CONNECT CHIP BACK TO V_{CC} OR FLOAT

Logic Diagram

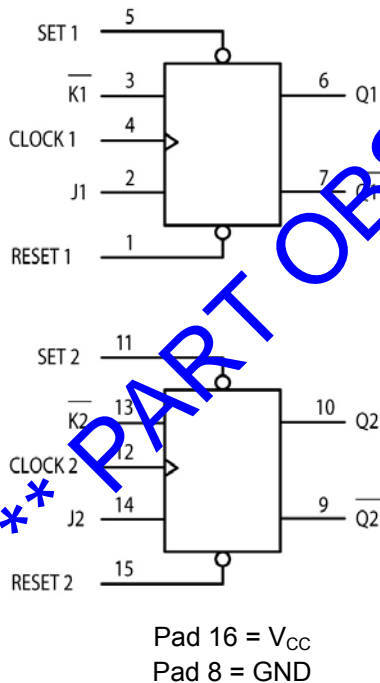

Truth Table

INPUTS					OUTPUTS	
SET	RESET	CLOCK	J	\overline{K}	Q	\overline{Q}
L	H	X	X	X	H	L
H	L	X	X	X	L	H
L	L	X	X	X	H*	H*
H	H	\nearrow	L	L	L	H
H	H	\nearrow	H	L	TOGGLE	
H	H	\nearrow	L	H	NO CHANGE	
H	H	\nearrow	H	H	H	L
H	H	L	X	X	NO CHANGE	

* Both outputs will remain high as long as Set and Reset are low, but the output states are unpredictable if Set and Reset go high simultaneously.





High Speed CMOS Logic – 54HC109

Rev 1.0

16/4/18

Absolute Maximum Ratings¹

PARAMETER	SYMBOL	VALUE	UNIT
DC Supply Voltage (Referenced to GND)	V_{CC}	-0.5 to +7.0	V
DC Input Voltage (Referenced to GND)	V_{IN}	-1.5 to $V_{CC} + 1.5$	V
DC Output Voltage (Referenced to GND)	V_{OUT}	-0.5 to $V_{CC} + 0.5$	V
DC Input Current, per pin	I_{IN}	± 20	mA
DC Output Current, per pin	I_{OUT}	± 25	mA
DC V_{CC} or GND Current, per pin	I_{CC}	± 50	mA
Power Dissipation in Still Air ²	P_D	750	mW
Storage Temperature Range	T_{STG}	-65 to +150	$^{\circ}C$

1. Operation above the absolute maximum rating may cause device failure. Operation at the absolute maximum ratings, for extended periods, may reduce device reliability. 2. Measured in plastic DIP package, results in die form are dependent on die attach and assembly method.

Recommended Operating Conditions³ (Voltages referenced to GND)

PARAMETER	SYMBOL	MIN	MAX	UNITS
DC Supply Voltage	V_{CC}	2	6	V
DC Input or Output Voltage	V_{IN}, V_{OUT}	0	V_{CC}	V
Operating Temperature Range	T_J	-55	+125	$^{\circ}C$
Input Rise and Fall Time	$V_{CC} = 2.0V$	0	1000	ns
	$V_{CC} = 4.5V$	0	500	
	$V_{CC} = 6.0V$	0	400	

3. This device contains protection circuitry to guard against damage due to high static voltages or electric fields. However, precautions must be taken to avoid applications of any voltage higher than maximum rated voltages to this high-impedance circuit. For proper operation, V_{IN} and V_{OUT} should be constrained to the range $GND \leq V_{IN} \text{ or } V_{OUT} \leq V_{CC}$. Unused inputs must always be tied to an appropriate logic voltage level (e.g., either GND or V_{CC}). Unused outputs must be left open.

DC Electrical Characteristics (Voltages Referenced to GND)

PARAMETER	SYMBOL	V_{CC}	CONDITIONS	LIMITS			UNITS
				25 $^{\circ}C$	85 $^{\circ}C$	FULL RANGE ⁴	
Minimum High-Level Input Voltage	V_{IH}	2.0V	$V_{OUT} = 0.1V \text{ or } V_{CC} - 0.1V$ $ I_{OUT} \leq 20\mu A$	1.5	1.5	1.5	V
		4.5V		3.15	3.15	3.15	
		6.0V		4.2	4.2	4.2	
Maximum Low-Level Input Voltage	V_{IL}	2.0V	$V_{OUT} = 0.1V \text{ or } V_{CC} - 0.1V$ $ I_{OUT} \leq 20\mu A$	0.3	0.3	0.3	V
		4.5V		0.9	0.9	0.9	
		6.0V		1.2	1.2	1.2	

4. -55 $^{\circ}C \leq T_J \leq +125^{\circ}C$





High Speed CMOS Logic – 54HC109

Rev 1.0

16/4/18

DC Electrical Characteristics (Voltages Referenced to GND)

PARAMETER	SYMBOL	V _{CC}	CONDITIONS	LIMITS			UNITS
				25°C	85°C	FULL RANGE ⁴	
Maximum Low-Level Output Voltage	V _{OL}	2.0V	V _{IN} = V _{IH} or V _{IL} I _{OUT} ≤ 20μA	0.1	0.1	0.1	V
		4.5V		0.1	0.1	0.1	
		6.0V		0.1	0.1	0.1	
		4.5V	V _{IN} = V _{IH} or V _{IL} I _{OUT} ≤ 4.0mA	0.26	0.33	0.40	
		6.0V		V _{IN} = V _{IL} I _{OUT} ≤ 5.2mA	0.26	0.33	
Maximum Input Leakage Current	I _{IN}	6.0V	V _{IN} = V _{CC} or GND		±0.1	±1.0	±1.0
Maximum Quiescent Supply Current	I _{CC}	6.0V	V _{IN} = V _{CC} or GND I _{OUT} = 0μA		40	80	μA

AC Electrical Characteristics⁵

PARAMETER	SYMBOL	V _{CC}	CONDITIONS	LIMITS			UNITS
				25°C	85°C	FULL RANGE ⁴	
Maximum Clock Frequency (50% Duty Cycle) (Figure 1,4)	f _{max}	2.0V	C _L = 50pF, t _r = t _f = 6ns	6.0	4.8	4.0	MHz
		4.5V		30	24	20	
		6.0V		35	28	24	
Maximum Propagation Delay, Clock to Q or Q̄ (Figure 1,4)	t _{PLH} , t _{PHL}	2.0V	C _L = 50pF, t _r = t _f = 6ns	175	220	265	ns
		4.5V		35	44	53	
		6.0V		30	37	45	
Maximum Propagation Delay, Set or Reset to Q or Q̄ (Figure 2,4)	t _{PLH} , t _{PHL}	2.0V	C _L = 50pF, t _r = t _f = 6ns	230	290	345	ns
		4.5V		46	58	69	
		6.0V		39	49	59	
Maximum Output Rise and Fall Time (Figure 1,4)	t _{TLH} , t _{THL}	2.0V	C _L = 50pF, t _r = t _f = 6ns	75	95	110	ns
		4.5V		15	19	22	
		6.0V		13	16	19	
Maximum Input Capacitance	C _{IN}	-	-	10	10	10	pF
Power Dissipation Capacitance (Per Flip-Flop) ⁶	C _{PD}	-	T _J = 25°C, V _{CC} = 5.0V	TYPICAL			pF
				40			

5. Not production tested in die form, characterized by chip design and tested in package.

6. Used to determine the no-load dynamic power consumption: P_D = C_{PD} V_{CC}²f + I_{CC} V_{CC}.





High Speed CMOS Logic – 54HC109

Rev 1.0

16/4/18

Timing Requirements⁵

PARAMETER	SYMBOL	V _{CC}	CONDITIONS	LIMITS			UNITS
				25°C	85°C	FULL RANGE	
Minimum Setup Time, J or K to Clock (Figure 3)	t _{su}	2.0V	Input t _r = t _f = 6ns	100	125	150	ns
		4.5V		20	25	30	
		6.0V		17	21	26	
Minimum Hold Time, Clock to J or K (Figure 3)	t _h	2.0V	Input t _r = t _f = 6ns	5	5	5	ns
		4.5V		5	5	5	
		6.0V		5	5	5	
Minimum Recovery Time, Set or Reset Inactive to Clock (Figure 2)	t _{rec}	2.0V	Input t _r = t _f = 6ns	5	5	5	ns
		4.5V		5	5	5	
		6.0V		5	5	5	
Minimum Pulse Width, Set or Reset (Figure 2)	t _w	2.0V	Input t _r = t _f = 6ns	80	100	120	ns
		4.5V		16	20	24	
		6.0V		14	17	20	
Minimum Pulse Width, Clock (Figure 2)	t _w	2.0V	Input t _r = t _f = 6ns	80	100	120	ns
		4.5V		16	20	24	
		6.0V		14	17	20	
Maximum Input Rise and Fall Times (Figure 1)	t _r , t _f	2.0V	Input t _r = t _f = 6ns	1000	1000	1000	ns
		4.5V		500	500	500	
		6.0V		400	400	400	

Switching Waveforms

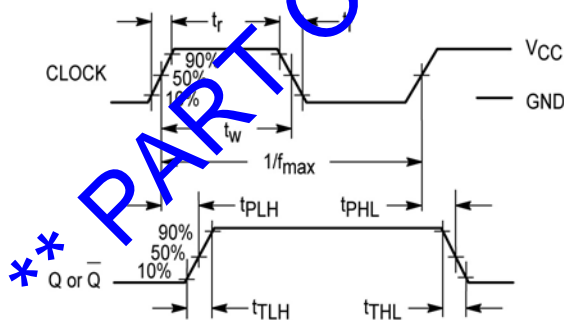

Figure 1

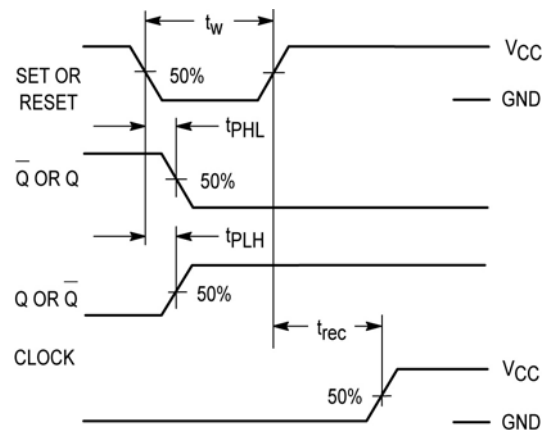

Figure 2





High Speed CMOS Logic – 54HC109

Rev 1.0
16/4/18

Switching Waveforms

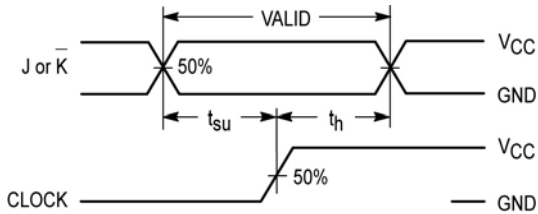

Figure 3

Test Circuit

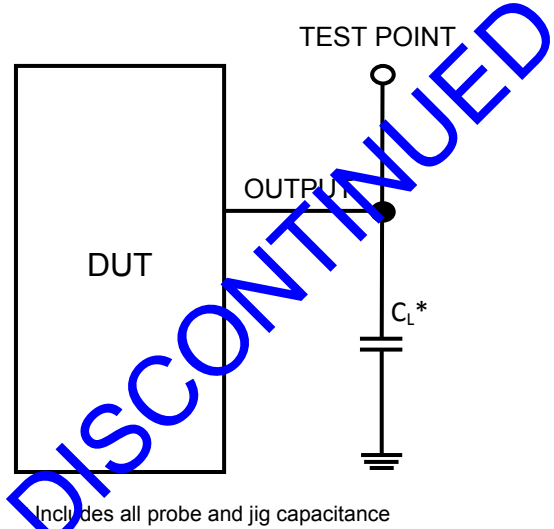

Figure 4

DISCLAIMER: The information given in this document shall in no event be regarded as a guarantee of conditions or characteristics. With respect to any examples or hints given herein, any typical values stated herein and/or any information regarding the application of the device, Silicon Supplies Ltd hereby disclaims any and all warranties and liabilities of any kind.

LIFE SUPPORT POLICY: Silicon Supplies Ltd components may be used in life support devices or systems only with the express written approval of Silicon Supplies Ltd, if a failure of such components can reasonably be expected to cause the failure of that life support device or system or to affect the safety or effectiveness of that device or system. Life support devices or systems are intended to be implanted in the human body or to support and/or maintain and sustain and/or protect human life. If they fail, it is reasonable to assume that the health of the user or other persons may be endangered.

