



High Speed CMOS Logic – 54HC03

Quad 2-Input Open Drain NAND Gate in bare die form

Rev 1.0
16/04/18

Description

The 54HC03 is fabricated using a 2.5µm 5V CMOS process and has the same high speed performance of LSTTL combined with CMOS low power consumption. This device is comprised of 3 stages including buffer output, which enables high noise immunity with stable output. With an external pull-up resistor the device can be used in wired AND configuration. This device can be also used as an LED driver and in any other application requiring a current sink. All inputs are protected from damage due to static discharge by internal diode clamps to V_{CC} and Ground.

Features:

- Output Drive Capability: 10 LSTTL Loads
- Low Input Current: 1µA
- Outputs directly interface CMOS, NMOS and TTL
- Operating Voltage Range: 2V to 6V
- CMOS High Noise Immunity
- Function compatible with 54LS03
- Full Military Temperature Range.

Ordering Information

The following part suffixes apply:

- No suffix - MIL-STD-883 /2010B Visual Inspection
- "H" - MIL-STD-883 /2010B Visual Inspection + MIL-PRF-38534 Class H LAT
- "K" - MIL-STD-883 /2010A Visual Inspection (Space) + MIL-PRF-38534 Class K LAT

LAT = Lot Acceptance Test.

For further information on LAT process flows see below.

www.siliconsupplies.com/quality/bare-die-lot-qualification

Die Dimensions in µm (mils)

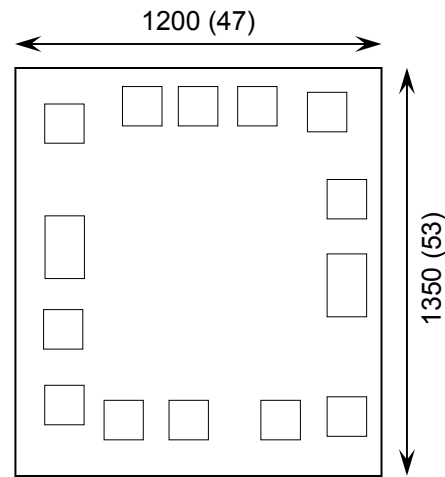

Supply Formats:

- Default – Die in Waffle Pack (400 per tray capacity)
- Sawn Wafer on Tape – On request
- Unsawn Wafer – On request
- Die Thickness <=> 350µm(14 Mils) – On request
- Assembled into Ceramic Package – On request

Mechanical Specification

Die Size (Unsawn)	1200 x 1350 47 x 53	µm mils
Minimum Bond Pad Size	106 x 106 4.17 x 4.17	µm mils
Die Thickness	350 (±20) 13.78 (±0.79)	µm mils
Top Metal Composition	Al 1%Si 1.1µm	
Back Metal Composition	N/A – Bare Si	





High Speed CMOS Logic – 54HC03

Rev 1.0
16/04/18

Pad Layout and Functions

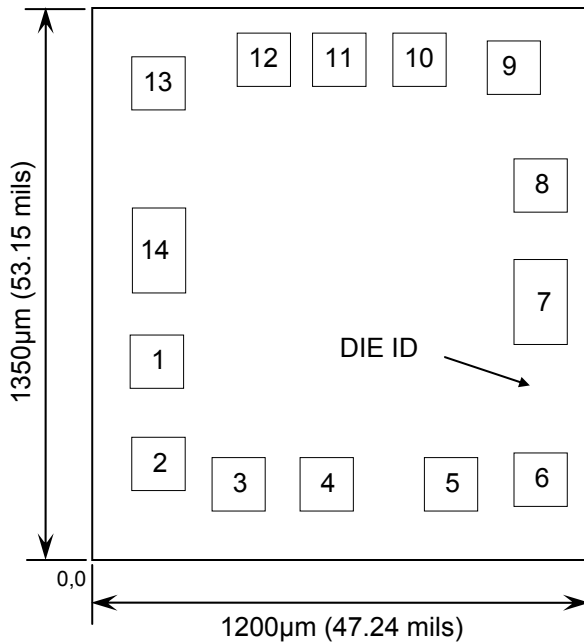

PAD	FUNCTION	COORDINATES (mm)	
		X	Y
1	A1	0.131	0.460
2	B1	0.131	0.153
3	Y1	0.305	0.121
4	A2	0.489	0.121
5	B2	0.786	0.121
6	Y2	0.970	0.131
7	GND	0.980	0.462
8	Y3	0.980	0.764
9	A3	0.950	1.115
10	B3	0.713	1.125
11	Y4	0.543	1.125
12	A4	0.369	1.125
13	B4	0.131	1.091
14	V _{CC}	0.131	0.631

CONNECT CHIP BACK TO V_{CC} OR FLOAT

Logic Diagram

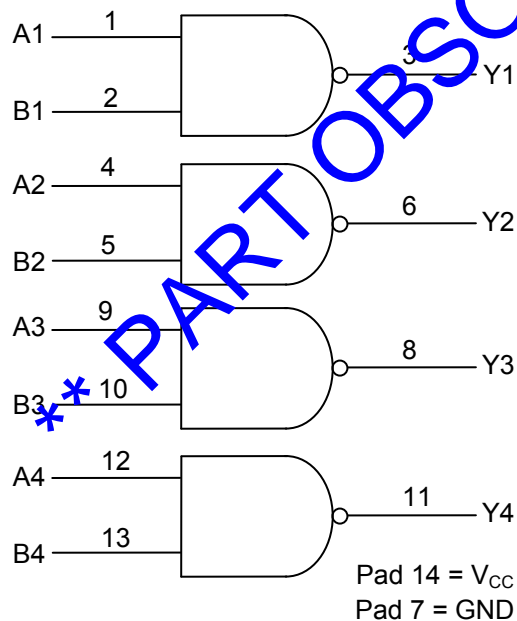

Truth Table

INPUTS		OUTPUT
A	B	Y
L	L	Z
L	H	Z
H	L	Z
H	H	L

H = High level (steady state)
L = Low level (steady state)
Z = High Impedance state





High Speed CMOS Logic – 54HC03

Rev 1.0

16/04/18

Absolute Maximum Ratings¹

PARAMETER	SYMBOL	VALUE	UNIT
DC Supply Voltage (Referenced to GND)	V_{CC}	-0.5 to +7.0	V
DC Input Voltage (Referenced to GND)	V_{IN}	-1.5 to $V_{CC} + 1.5$	V
DC Output Voltage (Referenced to GND)	V_{OUT}	-0.5 to $V_{CC} + 0.5$	V
DC Input Current, per pin	I_{IN}	±20	mA
DC Output Current, per pin	I_{OUT}	±25	mA
DC V_{CC} or GND Current, per pin	I_{CC}	±50	mA
Power Dissipation in Still Air ²	P_D	750	mW
Storage Temperature Range	T_{STG}	-65 to +150	°C

1. Operation above the absolute maximum rating may cause device failure. Operation at the absolute maximum ratings, for extended periods, may reduce device reliability. 2. Measured in plastic DIP package, results in die form are dependent on die attach and assembly method.

Recommended Operating Conditions³ (Voltages referenced to GND)

PARAMETER	SYMBOL	MIN	MAX	UNITS
DC Supply Voltage	V_{CC}	2	6	V
DC Input or Output Voltage	V_{IN}, V_{OUT}	0	V_{CC}	V
Operating Temperature Range	T_J	-55	+125	°C
Input Rise and Fall Time	$V_{CC} = 2.0V$	0	1000	ns
	$V_{CC} = 4.5V$	0	500	
	$V_{CC} = 6.0V$	0	400	

3. This device contains protection circuitry to guard against damage due to high static voltages or electric fields. However, precautions must be taken to avoid applications of any voltage higher than maximum rated voltages to this high-impedance circuit. For proper operation, V_{IN} and V_{OUT} should be constrained to the range $GND \leq (V_{IN} \text{ or } V_{OUT}) \leq V_{CC}$. Unused inputs must always be tied to an appropriate logic voltage level (e.g., either GND or V_{CC}). Unused outputs must be left open.

DC Electrical Characteristics (Voltages Referenced to GND)

PARAMETER	SYMBOL	V_{CC}	CONDITIONS	LIMITS			UNITS
				25°C	85°C	FULL RANGE ⁴	
Minimum High-Level Input Voltage	V_{IH}	2.0V	$V_{OUT} = 0.1V$ or $V_{CC} - 0.1V$ $ I_{OUT} \leq 20\mu A$	1.5	1.5	1.5	V
		4.5V		3.15	3.15	3.15	
		6.0V		4.2	4.2	4.2	
Maximum Low-Level Input Voltage	V_{IL}	2.0V	$V_{OUT} = 0.1V$ or $V_{CC} - 0.1V$ $ I_{OUT} \leq 20\mu A$	0.5	0.5	0.5	V
		4.5V		1.35	1.35	1.35	
		6.0V		1.8	1.8	1.8	

4. $-55^\circ C \leq T_J \leq +125^\circ C$





High Speed CMOS Logic – 54HC03

Rev 1.0
16/04/18

DC Electrical Characteristics (Voltages Referenced to GND)

PARAMETER	SYMBOL	V _{CC}	CONDITIONS	LIMITS			UNITS
				25°C	85°C	FULL RANGE ⁴	
Maximum Low-Level Output Voltage	V _{OL}	2.0V	V _{IN} = V _{IH} I _{OUT} ≤ 20μA	0.1	0.1	0.1	V
		4.5V		0.1	0.1	0.1	
		6.0V		0.1	0.1	0.1	
		4.5V	V _{IN} = V _{IH} I _{OUT} ≤ 4.0mA	0.26	0.33	0.40	
		6.0V	V _{IN} = V _{IH} I _{OUT} ≤ 5.2mA	0.26	0.33	0.40	
Maximum Input Leakage Current	I _{IN}	6.0V	V _{IN} = V _{CC} or GND	±0.1	±1.0	±1.0	μA
Maximum 3-State leakage current	I _{OZ}	6.0V	V _{OUT} = V _{CC} or GND V _{IN} = V _{IL} or V _{IH}	±0.5	±5.0	±10	μA
Maximum Quiescent Supply Leakage Current	I _{CC}	6.0V	V _{IN} = V _{CC} or GND I _{OUT} = 0μA	1	10	40	μA

AC Electrical Characteristics⁵

PARAMETER	SYMBOL	V _{CC}	CONDITIONS	LIMITS			UNITS
				25°C	85°C	FULL RANGE ⁴	
Maximum Propagation Delay, A or B to Y (Figures 2,4)	t _{PLZ} , t _{PZL}	2.0V	C _L = 50pF, t _r = t _f = 6ns	120	150	180	ns
		4.5V		24	30	36	
		6.0V		20	26	31	
Maximum Output Transition Time, any Output (Figures 2,4)	t _{TH}	2.0V	C _L = 50pF, t _r = t _f = 6ns	75	95	110	ns
		4.5V		15	19	22	
		6.0V		13	16	19	
Maximum Input Capacitance	C _{IN}	-	-	10	10	10	pF
Maximum Three-State Output Capacitance (Output in High-Impedance State)	C _{OUT}	-	-	10	10	10	pF
Power Dissipation Capacitance (Per Gate) ⁶	C _{PD}	-	T _A = 25°C, V _{CC} = 5.0V	TYPICAL			pF
				8			

5. Not production tested in die form, characterized by chip design and tested in package LAT.

6. Used to determine the no-load dynamic power consumption: P_D = C_{PD} V_{CC}²f + I_{CC} V_{CC}.





High Speed CMOS Logic – 54HC03

Rev 1.0
16/04/18

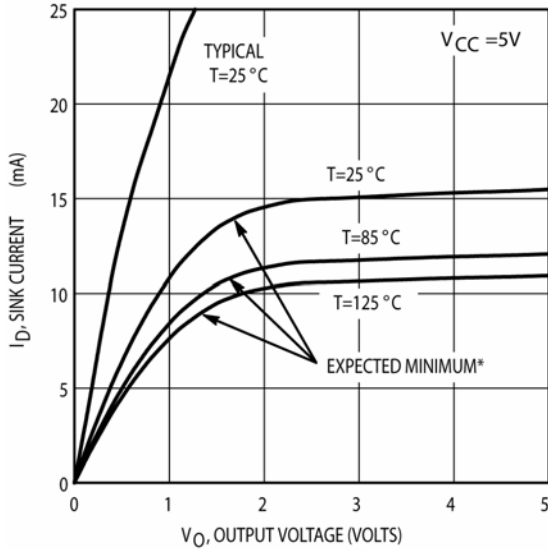

Figure 1 – Open-Drain Output Characteristics

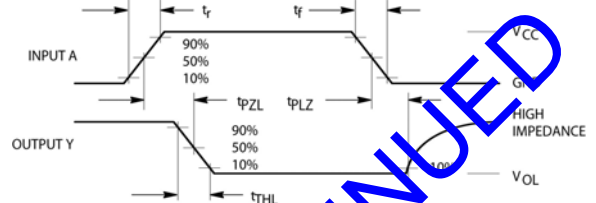

Figure 2 – Switching Waveforms

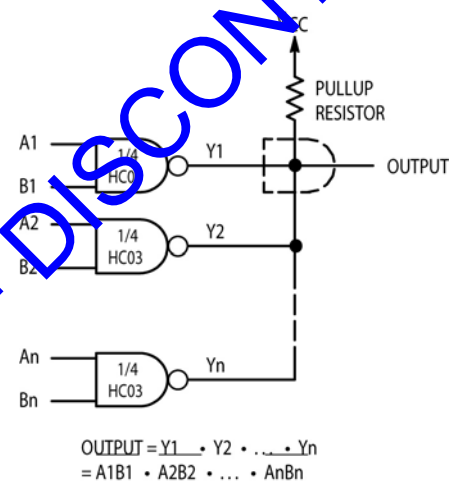

Figure 3 – Wired AND

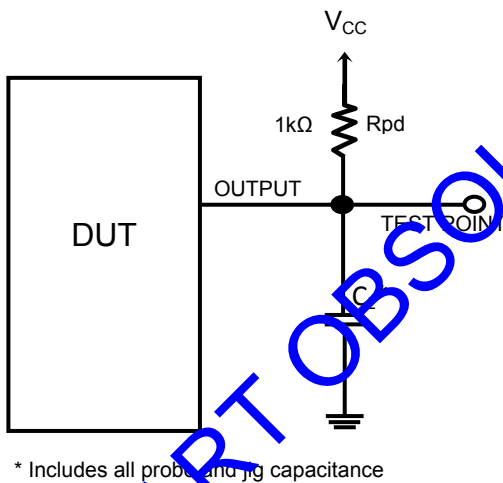

Figure 4 – Test Circuit

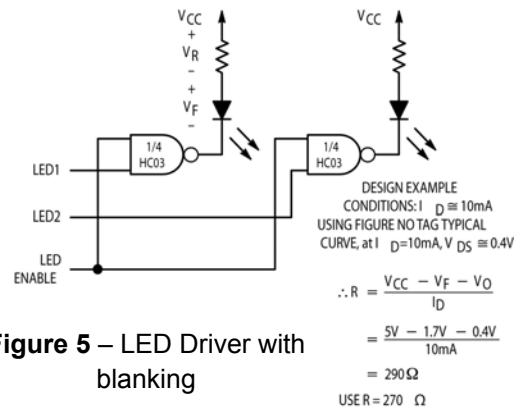

Figure 5 – LED Driver with blanking

DISCLAIMER: The information given in this document shall in no event be regarded as a guarantee of conditions or characteristics. With respect to any examples or hints given herein, any typical values stated herein and/or any information regarding the application of the device, Silicon Supplies Ltd hereby disclaims any and all warranties and liabilities of any kind.

LIFE SUPPORT POLICY: Silicon Supplies Ltd components may be used in life support devices or systems only with the express written approval of Silicon Supplies Ltd, if a failure of such components can reasonably be expected to cause the failure of that life support device or system or to affect the safety or effectiveness of that device or system. Life support devices or systems are intended to be implanted in the human body or to support and/or maintain and sustain and/or protect human life. If they fail, it is reasonable to assume that the health of the user or other persons may be endangered.

