



Advanced CMOS TTL Input – 54ACT574

8-bit non-inverting D-Type Flip-Flop with 3-State Outputs in bare die form

Rev 1.0
19/3/2021

Description

The 54ACT574 is fabricated using a 1.5µm 5V CMOS process combining high speed performance LSTTL performance with CMOS low power consumption. The device integrates eight D-type Flip-Flops, a buffered common Clock (CLK) and a buffered common Output Enable (\overline{OE}). The information presented to the D-type inputs is stored in the flip-flops on the LOW-to-HIGH Clock (CLK) transition. Device inputs directly accept both standard CMOS and LSTTL outputs. All inputs are equipped with protection circuits against static discharge and transient excess voltage.

Features:

- Outputs Source/Sink 24 mA
- Low Input Current: 1µA
- TTL / CMOS compatible Input Levels
- Outputs directly interface CMOS, NMOS and TTL
- Operating Voltage Range: 4.5V to 5.5V
- Function compatible with 54LS574
- Full Military Temperature Range.

Ordering Information

The following part suffixes apply:

- No suffix - MIL-STD-883 /2010B Visual Inspection
- "H" - MIL-STD-883 /2010B Visual Inspection + MIL-PRF-38534 Class H LAT
- "K" - MIL-STD-883 /2010A Visual Inspection (Space) + MIL-PRF-38534 Class K LAT

LAT = Lot Acceptance Test.

For further information on LAT process flows see below.

www.siliconsupplies.com/quality/bare-die-lot-qualification

Die Dimensions in µm (mils)

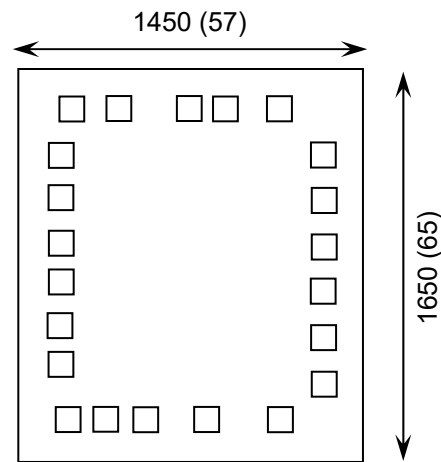

Supply Formats:

- Default – Die in Waffle Pack (100 per tray capacity)
- ~~Sawn Wafer on Tape~~ – On request
- Unsawn Wafer – On request
- Die Thickness <=> 350µm(14 Mils) – On request
- Assembled into Ceramic Package – On request

Mechanical Specification

Die Size (Unsawn)	1450 x 1650 57 x 65	µm mils
Minimum Bond Pad Size	108 x 108 4.25 x 4.25	µm mils
Die Thickness	350 (±20) 13.78 (±0.79)	µm mils
Top Metal Composition	Al 1%Si 1.1µm	
Back Metal Composition	N/A – Bare Si	





Advanced CMOS TTL Input – 54ACT574

Rev 1.0
19/3/2021

Pad Layout and Functions

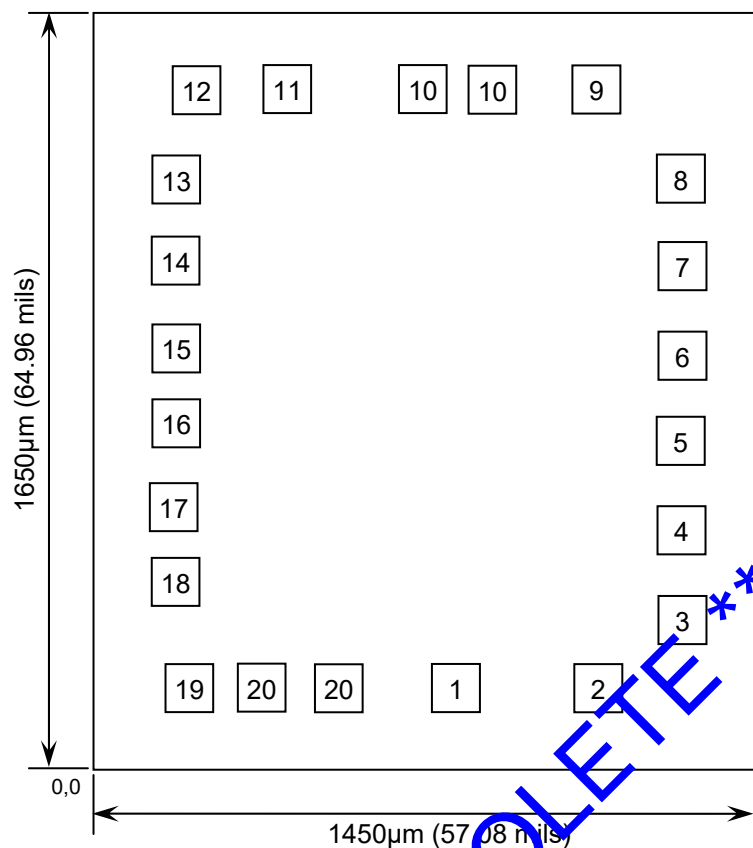

PAD	FUNCTION	COORDINATES (mm)	
		X	Y
1	\overline{OE}	0.735	0.100
2	1D	1.050	0.100
3	2D	1.23	0.280
4	3D	1.23	0.470
5	4D	1.23	0.660
6	5D	1.23	0.860
7	6D	1.23	1.050
8	7D	1.23	1.250
9	8D	1.050	1.430
10	GND	0.810	1.430
10	GND	0.660	1.430
11	CLK	0.370	1.430
12	8Q	0.140	1.430
13	7Q	0.100	1.220
14	6Q	0.100	1.040
15	5Q	0.100	0.860
16	4Q	0.100	0.680
17	3Q	0.100	0.500
18	2Q	0.100	0.320
19	1Q	0.140	0.100
20	V _{CC}	0.320	0.100
20	V _{CC}	0.470	0.100

CONNECT CHIP BACK TO V_{CC} OR FLOAT

Logic Diagram

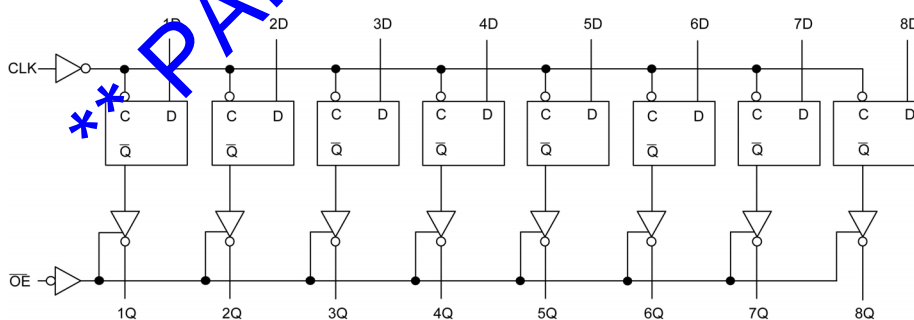

Pad 10 = GND, Pad 20 = V_{CC}

Truth Table

INPUTS			OUTPUT
\overline{OE}	CLK	D	Q
L	↑	H	H
L	↑	L	L
L	L,H ↓	X	No Change
H	X	X	Z

H = High level (steady state)
L = Low level (steady state)
Z = High Impedance
X = Don't care





Advanced CMOS TTL Input – 54ACT574

Rev 1.0
19/3/2021

Absolute Maximum Ratings¹

PARAMETER	SYMBOL	VALUE	UNIT
DC Supply Voltage (Referenced to GND)	V_{CC}	-0.5 to +7.0	V
DC Input Voltage (Referenced to GND)	V_{IN}	-0.5 to $V_{CC} + 0.5$	V
DC Output Voltage (Referenced to GND)	V_{OUT}	-0.5 to $V_{CC} + 0.5$	V
DC Input Current, per pad	I_{IN}	± 20	mA
DC Output Current, per pad	I_{OUT}	± 50	mA
DC Supply Current, V_{CC} or GND	I_{CC}	± 50	mA
Power Dissipation in Still Air ²	P_D	750	mW
Storage Temperature Range	T_{STG}	-65 to +150	$^{\circ}C$

1. Operation above the absolute maximum rating may cause device failure. Operation at the absolute maximum ratings, for extended periods, may reduce device reliability. 2. Measured in plastic DIP package, results in die form are dependent on die attach and assembly method.

Recommended Operating Conditions³ (Voltages referenced to GND)

PARAMETER	SYMBOL	MIN	MAX	UNITS	
DC Supply Voltage	V_{CC}	4.5	5.5	V	
DC Input or Output Voltage	V_{IN}, V_{OUT}	0	V_{CC}	V	
Operating Temperature Range	T_J	-55	+125	$^{\circ}C$	
Output current - High	I_{OH}	-	-24	mA	
Output current - Low	I_{OL}	-	24	mA	
Input Rise or Fall rate (V_{IN} from 0.8V to 2V)	$\Delta t/\Delta V$	$V_{CC} = 4.5V$	0	10	ns/V
		$V_{CC} = 5.5V$	0	8	

3. This device contains protection circuitry to guard against damage due to high static voltages or electric fields. However, precautions must be taken to avoid applications of any voltage higher than maximum rated voltages to this high-impedance circuit. For proper operation, V_{IN} and V_{OUT} should be constrained to the range $GND \leq (V_{IN} \text{ or } V_{OUT}) \leq V_{CC}$. Unused inputs must always be tied to an appropriate logic voltage level (e.g., either GND or V_{CC}). Unused outputs must be left open.

DC Electrical Characteristics (Voltages referenced to GND)

PARAMETER	SYMBOL	V_{CC}	CONDITIONS	LIMITS			UNITS
				25 $^{\circ}C$	85 $^{\circ}C$	FULL RANGE ⁴	
Minimum High-Level Input Voltage	V_{IH}	4.5V	$V_{OUT} = 0.1V$ or $V_{CC} - 0.1V$	2	2	2	V
		5.5V		2	2	2	
Maximum Low-Level Input Voltage	V_{IL}	4.5V	$V_{OUT} = 0.1V$ or $V_{CC} - 0.1V$	0.8	0.8	0.8	V
		5.5V		0.8	0.8	0.8	
Minimum High-Level Output Voltage	V_{OH}	4.5V	$I_{OUT} = -50\mu A$	4.4	4.4	4.4	V
		5.5V		5.4	5.4	5.4	
		4.5V	$V_{IN} = V_{IL}$ or V_{IH} ⁵ $I_{OH} = -24mA$	3.86	3.76	3.70	V
		5.5V		4.86	4.76	4.70	

4. -55 $^{\circ}C \leq T_J \leq +125^{\circ}C$





Advanced CMOS TTL Input – 54ACT574

Rev 1.0
19/3/2021

DC Electrical Characteristics Continued (Voltages Referenced to GND)

PARAMETER	SYMBOL	V _{CC}	CONDITIONS	LIMITS			UNITS
				25°C	85°C	FULL RANGE ⁴	
Maximum Low-Level Output Voltage	V _{OL}	4.5V	I _{OUT} = 50µA	0.1	0.1	0.1	V
		5.5V		0.1	0.1	0.1	
		4.5V	V _{IN} = V _{IL} or V _{IH} ⁵ I _{OL} = 24mA	0.36	0.44	0.30	V
		5.5V		0.36	0.44	0.50	
Maximum Input Leakage Current	I _{IN}	5.5V	V _{IN} = V _{CC} or GND	±0.1	±1.0	±1.0	µA
Maximum 3-State leakage current	I _{OZ}	5.5V	V _{OUT} =V _{CC} or GND V _{IN} = V _{IL} or V _{IH}	±0.5	±2.5	±5	µA
Additional Maximum I _{CC} / Input	ΔI _{CCT}	5.5V	V _{IN} = V _{CC} -2.1V	1	1.5	1.6	mA
Minimum Dynamic Output Current ⁶	I _{OLD}	5.5V	V _{OLD} = 1.65V Max		75	50	mA
	I _{OHD}	5.5V	V _{OHD} = 3.85V Min		-75	-50	
Maximum Quiescent Supply Leakage Current	I _{CC}	5.5V	V _{IN} = V _{CC} or GND I _{OUT} = 0µA	8	80	160	µA

5. All outputs loaded; thresholds on input associated with output under test. 6. Maximum test duration 2.0 ms, one output loaded at a time.

AC Electrical Characteristics⁷

PARAMETER	SYMBOL	V _{CC}	CONDITIONS	LIMITS			UNITS
				25°C	85°C	FULL RANGE ⁴	
Maximum Clock Frequency	f _{max}	5V ±0.5	C _L = 50pF, Input t _r =t _f = 3ns	100	85	70	MHz
Propagation Delay CLK to Q (Figure 1,5)	t _{PLH}	5V ±0.5	C _L = 50pF, Input t _r =t _f = 3ns	11	12	13.5	ns
	t _{PIL}			10	11	12.5	
Output Enable Time OE to Q (Figure 3,6)	t _{PZH}	5V ±0.5	C _L = 50pF, Input t _r =t _f = 3ns	9.5	10	11	ns
	t _{PZL}			9.0	10	11	
Output Enable Time OE to Q (Figure 3,6)	t _{PHZ}	5V ±0.5	C _L = 50pF, Input t _r =t _f = 3ns	10.5	11.5	12	ns
	t _{PLZ}			8.5	9.0	10	
Maximum Input Capacitance	C _{IN}	5V ±0.5	C _L = 50pF, Input t _r =t _f = 3ns	10	10	10	pF
Power Dissipation Capacitance ⁷	C _{PD}	-	T _J = 25°C, V _{CC} =5.0V	TYPICAL			pF
				40			

7. Not production tested in die form, characterized by chip design.





Advanced CMOS TTL Input – 54ACT574

Rev 1.0
19/3/2021

Timing Requirements⁶

PARAMETER	SYMBOL	V _{CC}	CONDITIONS	LIMITS			UNITS
				25°C	85°C	FULL RANGE ⁴	
Minimum Setup Time, D to CLK (Figure 2,4)	t _{su}	5V ±0.5	C _L = 50pF, Input t _r =t _f = 3ns	2.5	2.5	3.5	ns
Minimum Hold Time, CLK to D (Figure 2,4)	t _h	5V ±0.5	C _L = 50pF, Input t _r =t _f = 3ns	1.0	1.0	2.0	ns
Minimum Pulse Width, CLK (Figure 2,4)	t _w	5V ±0.5	C _L = 50pF, Input t _r =t _f = 3ns	3.0	4.0	5.0	ns

Switching Waveforms

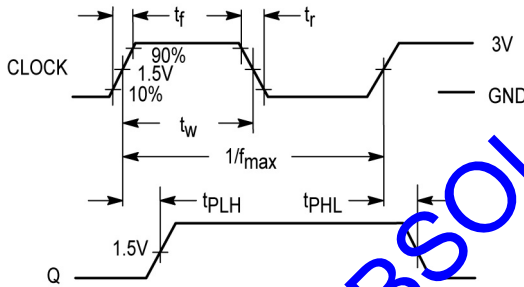

Figure 1 – Propagation Delay & Output Transition Time

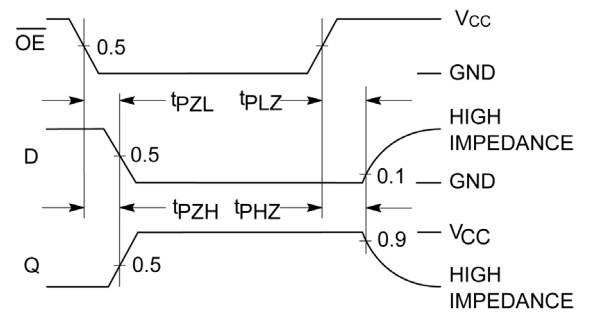

Figure 3 – Propagation Delay - Output Enable to Q

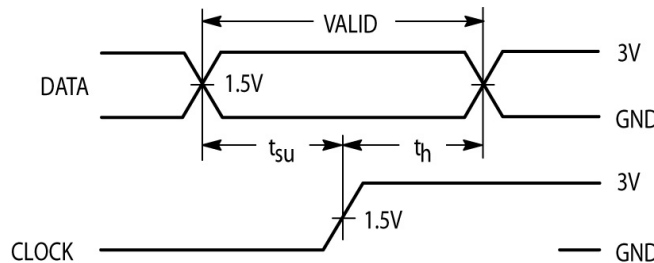

Figure 4 – Timing Requirements





Advanced CMOS TTL Input – 54ACT574

Rev 1.0
19/3/2021

Test Circuits

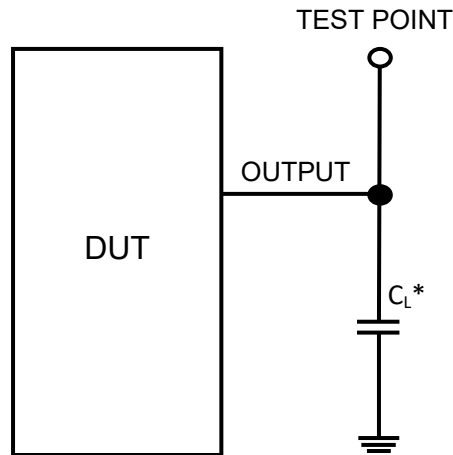

* Includes all probe and jig capacitance

Figure 5

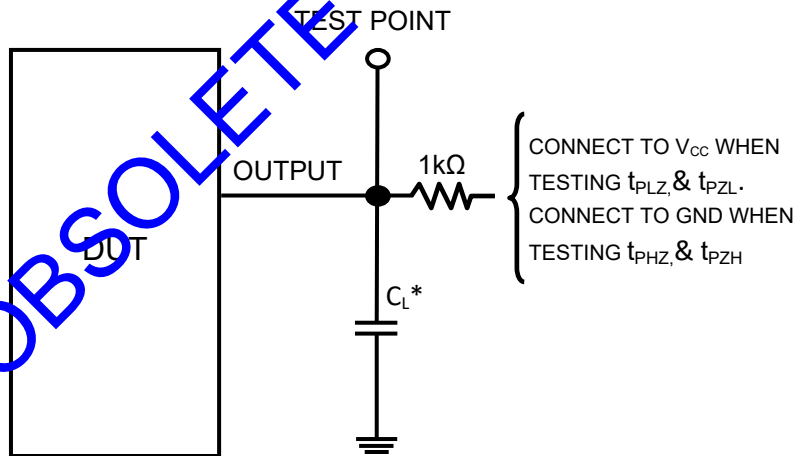

* Includes all probe and jig capacitance

Figure 6

DISCLAIMER: The information given in this document shall in no event be regarded as a guarantee of conditions or characteristics. With respect to any examples or hints given herein, any typical values stated herein and/or any information regarding the application of the device, Silicon Supplies Ltd hereby disclaims any and all warranties and liabilities of any kind.

LIFE SUPPORT POLICY: Silicon Supplies Ltd components may be used in life support devices or systems only with the express written approval of Silicon Supplies Ltd, if a failure of such components can reasonably be expected to cause the failure of that life support device or system or to affect the safety or effectiveness of that device or system. Life support devices or systems are intended to be implanted in the human body or to support and/or maintain and sustain and/or protect human life. If they fail, it is reasonable to assume that the health of the user or other persons may be endangered.

