



Advanced CMOS TTL Input – 54ACT11

Triple 3-Input AND gate with LSTTL compatible inputs in bare die form

Rev 1.0
11/03/19

Description

The 54ACT11 is fabricated using an advanced CMOS process combining LSTTL speed with CMOS low power consumption while delivering high output drive. The device contains x3 independent gates each performing Boolean function $Y = A \cdot B \cdot C$ or $Y = \overline{A} + \overline{B} + \overline{C}$ in positive logic. The device directly accepts LSTTL or NMOS inputs and suits use as a level converter for interfacing TTL or NMOS outputs to high speed CMOS inputs. All inputs are protected against ESD and excess voltage transients.

Features:

- Inputs directly accept TTL / NMOS
- Outputs directly interface CMOS, NMOS and TTL
- Outputs Sink/Source 24mA
- Low input current: 1µA
- High noise immunity
- Functionally compatible with bipolar 54LS/ALS11.
- Full military temperature Range

Ordering Information

The following part suffixes apply:

- No suffix - MIL-STD-883 /2010B Visual Inspection
- “H” - MIL-STD-883 /2010B Visual Inspection + MIL-PRF-38534 Class H LAT
- “K” - MIL-STD-883 /2010A Visual Inspection (Space) + MIL-PRF-38534 Class K LAT

LAT = Lot Acceptance Test.

For further information on LAT process flows see below.

www.siliconsupplies.com/quality/bare-die-lot-qualification

Die Dimensions in µm (mils)

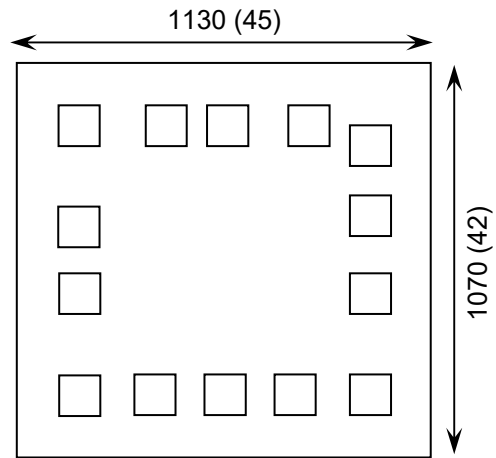

Supply Formats:

- Default – Die in Waffle Pack (400 per tray capacity)
- *** Sawn Wafer on Tape – On request
- Unsawn Wafer – On request
- Die Thickness <=> 350µm(14 Mils) – On request
- Assembled into Ceramic Package – On request

Mechanical Specification

Die Size (Unsawn)	1130 x 1070 45 x 42	µm mils
Minimum Bond Pad Size	108 x 108 4.25 x 4.25	µm mils
Die Thickness	350 (±20) 13.78 (±0.79)	µm mils
Top Metal Composition	Al 1%Si 1.1µm	
Back Metal Composition	N/A – Bare Si	





Advanced CMOS TTL Input – 54ACT11

Rev 1.0
11/03/19

Pad Layout and Functions

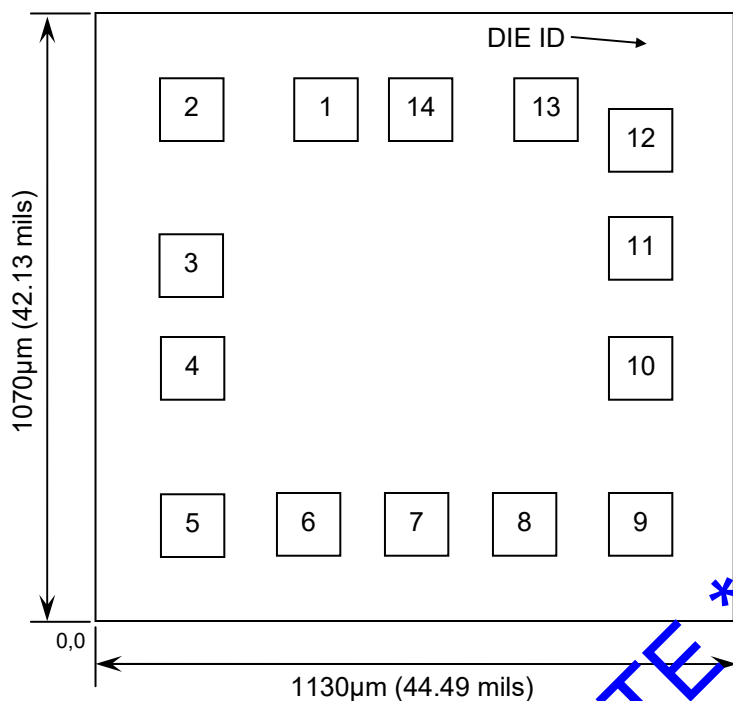

PAD	FUNCTION	COORDINATES (µm)	
		X	Y
1	1A	0.350	0.845
2	1B	0.115	0.845
3	2A	0.115	0.570
4	2B	0.115	0.390
5	2C	0.115	0.115
6	2Y	0.320	0.115
7	GND	0.510	0.115
8	3Y	0.705	0.115
9	3C	0.910	0.115
10	3B	0.910	0.390
11	3A	0.910	0.600
12	1Y	0.910	0.790
13	1C	0.740	0.845
14	V _{CC}	0.520	0.845

CONNECT CHIP BACK TO V_{CC} OR FLOAT

Logic Diagram

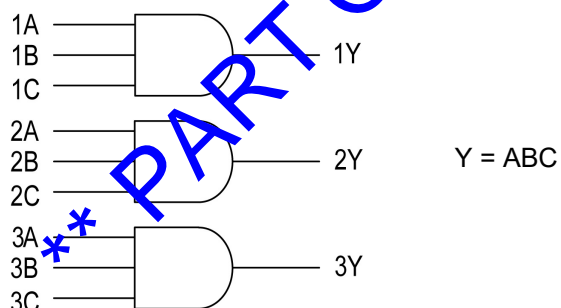

Truth Table

INPUTS			OUTPUT
A	B	C	Y
H	H	H	H
L	X	X	L
X	L	X	L
X	X	L	L

H = High level (steady state)
L = Low level (steady state)
X = Either Low or High level





Advanced CMOS TTL Input – 54ACT11

Rev 1.0

13/05/21

Absolute Maximum Ratings¹

PARAMETER	SYMBOL	VALUE	UNIT
DC Supply Voltage (Referenced to GND)	V_{CC}	-0.5 to +7.0	V
DC Input Voltage (Referenced to GND)	V_{IN}	-0.5 to $V_{CC} + 0.5$	V
DC Output Voltage (Referenced to GND)	V_{OUT}	-0.5 to $V_{CC} + 0.5$	V
DC Input Current	I_{IN}	± 20	mA
DC Output Current, per pad	I_{OUT}	± 50	mA
DC Supply Current, V_{CC} or GND, per pad	I_{CC}	± 50	mA
Storage Temperature Range	T_{STG}	-65 to +150	$^{\circ}C$

1. Operation above the absolute maximum rating may cause device failure. Operation at the absolute maximum ratings, for extended periods, may reduce device reliability.

Recommended Operating Conditions² (Voltages Referenced to GND)

PARAMETER	SYMBOL	MIN	MAX	UNITS	
Supply Voltage	V_{CC}	4.5	5.5	V	
DC Input or Output Voltage	V_{IN}, V_{OUT}	0	V_{CC}	V	
Operating Temperature Range	T_J	-55	+125	$^{\circ}C$	
Input Rise or Fall rate ³ (except Schmitt Inputs)	t_r, t_f	$V_{CC} = 4.5V$	0	10	ns/V
		$V_{CC} = 5.5V$	0	8	
Output Current – High	I_{OH}	-	-24	mA	
Output Current – Low	I_{OL}	-	24	mA	

2. This device contains protection circuitry to guard against damage due to high static voltages or electric fields. However, precautions must be taken to avoid applications of any voltage higher than maximum rated voltages to this high-impedance circuit. For proper operation, V_{IN} and V_{OUT} should be constrained to the range $GND \leq (V_{IN} \text{ or } V_{OUT}) \leq V_{CC}$. Unused inputs must always be tied to an appropriate logic voltage level (e.g., either GND or V_{CC}). Unused outputs must be left open. 3. V_{IN} from 1.0V to 2.0V

DC Electrical Characteristics (Voltages referenced to GND)

PARAMETER	SYMBOL	V_{CC}	CONDITIONS	LIMITS			UNITS
				25 $^{\circ}C$	85 $^{\circ}C$	FULL RANGE ⁴	
Minimum High-Level Input Voltage	V_{IH}	4.5V	$V_{OUT} = 0.1V \text{ or } V_{CC}$	2	2	2	V
		5.5V	-0.1V	2	2	2	
Maximum Low-Level Input Voltage	V_{IL}	4.5V	$V_{OUT} = 0.1V \text{ or } V_{CC}$	0.8	0.8	0.8	V
		5.5V	-0.1V	0.8	0.8	0.8	
Minimum High-Level Output Voltage	V_{OH}	4.5V	$I_{OUT} = -50\mu A$	4.4	4.4	4.4	V
		5.5V		5.4	5.4	5.4	
		4.5V	$V_{IN} = V_{IL} \text{ or } V_{IH}$ ⁵	3.86	3.76	3.70	V
		5.5V	$I_{OH} = -24mA$	4.86	4.76	4.70	

4. $-55^{\circ}C \leq T_J \leq +125^{\circ}C$





Advanced CMOS TTL Input – 54ACT11

Rev 1.0

13/05/21

DC Electrical Characteristics Continued (Voltages referenced to GND)

PARAMETER	SYMBOL	V _{CC}	CONDITIONS	LIMITS			UNITS
				25°C	85°C	FULL RANGE ⁴	
Maximum Low-Level Output Voltage	V _{OL}	4.5V	I _{OUT} = 50μA	0.1	0.1	0.1	V
		5.5V		0.1	0.1	0.1	
		4.5V	V _{IN} = V _{IL} or V _{IH} ⁵ I _{OL} = 24mA	0.36	0.44	0.50	V
		5.5V		0.36	0.44	0.50	
Maximum Input Leakage Current	I _{IN}	5.5V	V _{IN} = V _{CC} or GND	±0.1	±1.0	±1.0	μA
Additional Maximum I _{CC} / Input	ΔI _{CCT}	5.5V	V _{IN} = V _{CC} - 2.1V	1	1.5	1.6	mA
Minimum Dynamic Output Current ⁶	I _{OLD}	5.5V	V _{OLD} = 1.65V Max	-	75	50	mA
	I _{OHD}	5.5V	V _{OHD} = 3.85V Min	-	-75	-50	
Maximum Quiescent Supply Leakage Current	I _{CC}	5.5V	V _{IN} = V _{CC} or GND I _{OUT} = 0μA	4	40	80	μA

5. All outputs loaded; thresholds on input associated with output under test. 6. Maximum test duration 2.0 ms, one output loaded at a time.

AC Electrical Characteristics⁷

PARAMETER	SYMBOL	V _C	CONDITIONS	LIMITS			UNITS
				25°C	85°C	FULL RANGE ⁴	
Propagation Delay Input A,B,C to Output Y	t _{PLH}	5V ±0.5	C _L = 50pF, input t _r = t _f = 3.0ns	9.5	10.5	10.5	ns
Propagation Delay Input A,B,C to Output Y	t _{PFL}	5V ±0.5	C _L = 50pF, input t _r = t _f = 3.0ns	9.5	10.5	10.5	ns

Capacitance⁷ (V_{CC} = 5V, T_j = 25°C)

PARAMETER	SYMBOL	V _{CC}	CONDITIONS	LIMITS	UNITS
Input Capacitance	C _{IN}	5V	V _{IN} = V _{CC} or GND	4.5	pF
Power Dissipation Capacitance	C _{PD}	5V	C _L = 50pF, f = 1 MHz	TYPICAL	pF
				20	

7. Not production tested in die form, characterized by chip design and tested in package.





Advanced CMOS TTL Input – 54ACT11

Rev 1.0
13/05/21

Switching Waveform

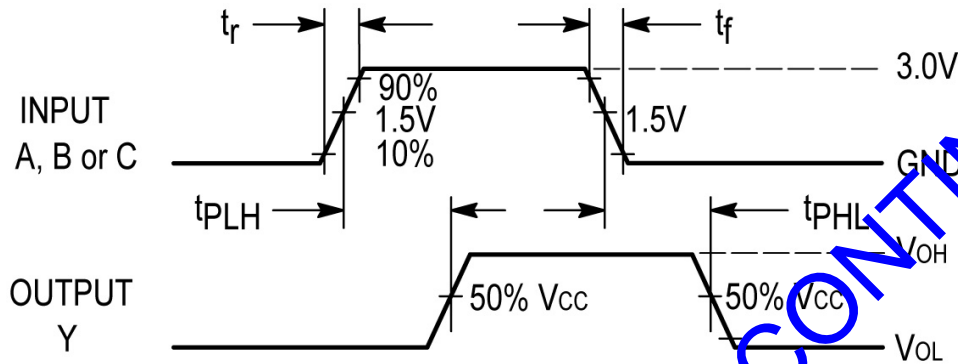
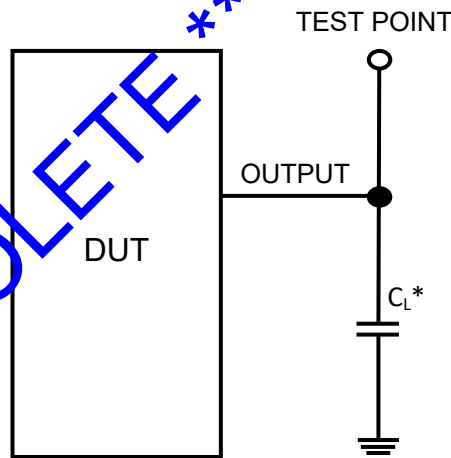

Figure 1 – Propagation Delay & Output Transition Time

Test Circuit



* Includes all probe and jig capacitance

Figure 2

DISCLAIMER: The information given in this document shall in no event be regarded as a guarantee of conditions or characteristics. With respect to any examples or hints given herein, any typical values stated herein and/or any information regarding the application of the device, Silicon Supplies Ltd hereby disclaims any and all warranties and liabilities of any kind.

LIFE SUPPORT POLICY: Silicon Supplies Ltd components may be used in life support devices or systems only with the express written approval of Silicon Supplies Ltd, if a failure of such components can reasonably be expected to cause the failure of that life support device or system or to affect the safety or effectiveness of that device or system. Life support devices or systems are intended to be implanted in the human body or to support and/or maintain and sustain and/or protect human life. If they fail, it is reasonable to assume that the health of the user or other persons may be endangered.

