

INN040W080A

1. General description

Bi-directional GaN-on-Silicon enhancement mode high-electron-mobility-transistor (HEMT) in WLCSP with 1.7 mm x 1.7 mm package size.

2. Features

- Bi-directional blocking capability
- GaN-on-Silicon E-mode HEMT technology
- Ultra-low on Resistance

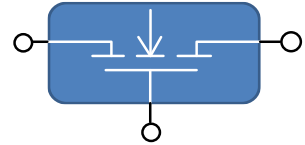

3. Applications

- High side load switch
- OVP protection in smart phone USB port
- Switch circuits in multiple power suppliers system

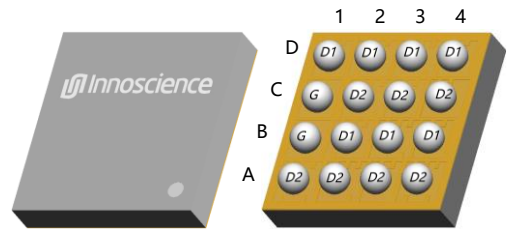

4. Key performance parameters

Table 1 Key performance parameters at $T_j = 25\text{ }^\circ\text{C}$

Parameter	Value	Unit
$V_{DD,max}$	40	V
$R_{DD(on),max}$ @ $V_G = 5\text{ V}$	8	m Ω
$Q_{G,typ}$ @ $V_{DD} = 20\text{ V}$	10.1	nC
$I_{D,DC}$	14	A

5. Pin information

Table 2 Pin information

Pin	Pin description	Pin function
D1~4, B2~4	Drain1	Power Drain1
C2~4, A1~4	Drain2	Power Drain2
B1, C1	Gate	Driver Gate

Table 3 Ordering information

Type/Ordering Code	Package	Product Code
INN040W080A	WLCSP 1.7x1.7	D16

Table of contents

1. General description	1
2. Features.....	1
3. Applications	1
4. Key performance parameters.....	1
5. Pin information.....	1
6. Maximum ratings	3
7. Thermal characteristics.....	4
8. Electric characteristics.....	5
9. Electric characteristics diagrams	7
10.Package outlines.....	12
11.Reel information.....	13
12.Land pattern	14
13.Revision history	15

6. Maximum ratings

at $T_j = 25\text{ }^\circ\text{C}$ unless otherwise specified.

Continuous application of maximum ratings can deteriorate transistor lifetime. For further information, contact Innoscence sales office.

Table 4 Maximum ratings

SYMBOL	PARAMETER	MAX	UNIT
V_{DD}	Drain1-to-Drain2 Voltage or Drain2-to-Drain1 Voltage	40	V
V_{DG}	Drain-to-Gate Voltage	40	V
V_{GD}	Gate-to-Drain Voltage	6	V
I_D	Continuous Drain current (limited by solder ball)	14	A
I_{DM}	Pulsed Drain Current (25°C , $T_{Pulse} = 300\ \mu\text{s}$)	70	A
T_J	Operating Temperature	-40 to 125	$^\circ\text{C}$
T_{STG}	Storage Temperature	-40 to 150	$^\circ\text{C}$

7. Thermal characteristics

Table 5 Thermal characteristics

SYMBOL	PARAMETER	TYP	UNIT
$R_{\theta JC}$	Thermal Resistance, Junction to Case	0.97	$^{\circ}\text{C}/\text{W}$
$R_{\theta JB}$	Thermal Resistance, Junction to Board	6.61	$^{\circ}\text{C}/\text{W}$
$R_{\theta JA}$	Thermal Resistance, Junction to Ambient ¹	65.12	$^{\circ}\text{C}/\text{W}$

Note 1: $R_{\theta JA}$ is determined with the device mounted on one square inch of copper pad, single layer 2 oz copper on FR4 board.

8. Electric characteristics

 at $T_j = 25\text{ }^\circ\text{C}$, unless specified otherwise

Table 6 Static characteristics

SYMBOL	PARAMETER	MIN	TYP	MAX	UNIT	TEST CONDITIONS
BV_{D1D2S}	Drain1-to-Drain2 Breakdown Voltage	40			V	$V_{D2} = V_G = 0\text{ V}$, $I_{D1D2} = 500\text{ }\mu\text{A}$
BV_{D2D1S}	Drain2-to-Drain1 Breakdown Voltage	40			V	$V_{D1} = V_G = 0\text{ V}$, $I_{D2D1} = 500\text{ }\mu\text{A}$
I_{D1D2S}	Zero Gate Voltage Drain Current			20	μA	$V_{D2} = V_G = 0\text{ V}$, $V_{D1} = 40\text{ V}$
I_{D2D1S}	Zero Gate Voltage Drain Current			20	μA	$V_{D1} = V_G = 0\text{ V}$, $V_{D2} = 40\text{ V}$
I_{GDS} ($T_J=85^\circ\text{C}$)	Gate-to-Drain Leakage		0.5	5	μA	$V_{D1} = V_{D2} = 0\text{ V}$, $V_G = 5\text{ V}$
	Gate-to-Drain Leakage	-30			μA	$V_{D1} = V_{D2} = 0\text{ V}$, $V_G = -5\text{ V}$
I_{GDS} ($T_J=85^\circ\text{C}$)	Gate-to-Drain Leakage		5	30	μA	$V_{D1} = V_{D2} = 0\text{ V}$, $V_G = 6\text{ V}$
	Gate-to-Drain Leakage	-40			μA	$V_{D1} = V_{D2} = 0\text{ V}$, $V_G = -6\text{ V}$
$V_{GD1(TH)}$	Gate Threshold Voltage	0.8		2.4	V	$V_{D1} = 0\text{ V}$, $V_{D2} = V_G$, $I_{D2D1} = 1\text{ mA}$
$V_{GD2(TH)}$	Gate Threshold Voltage	0.8		2.4	V	$V_{D2} = 0\text{ V}$, $V_{D1} = V_G$, $I_{D1D2} = 1\text{ mA}$
$R_{D1D2(on)}$	Drain1-to-Drain2 On-state Resistance		6.1	8	$\text{m}\Omega$	$V_{D2} = 0\text{ V}$, $V_{GD} = 5\text{ V}$, $I_{D1D2} = 10\text{ A}$
$R_{D2D1(on)}$	Drain2-to-Drain1 On-state Resistance		6.1	8	$\text{m}\Omega$	$V_{D1} = 0\text{ V}$, $V_{GD} = 5\text{ V}$, $I_{D2D1} = 10\text{ A}$

Table 7 Dynamic characteristics

SYMBOL	PARAMETER	MIN	TYP	MAX	UNIT	TEST CONDITIONS
C _{ISS}	Input Capacitance		566		pF	V _G = 0 V, V _D = 20 V
C _{OSS}	Output Capacitance		243			
C _{RSS}	Reverse Transfer Capacitance		145			
R _G	Gate Resistance		4.1		Ω	f = 1 MHz
Q _G	Total Gate Charge		10.1		nC	V _D = 20 V, V _G = 5 V, I _D = 10 A
Q _{GD1}	Gate-to-Drain1 Charge (V _{D2D1} =20V)		1.2			V _{D1} = 0, V _{D2} = 20 V, I _{D2D1} = 10 A
Q _{GD1}	Gate-to-Drain1 Charge (V _{D1D2} =20V)		5.5			V _{D2} = 0, V _{D1} = 20 V, I _{D1D2} = 10 A
Q _{GD2}	Gate-to-Drain2 Charge (V _{D1D2} =20V)		1.2			V _{D2} = 0, V _{D1} = 20 V, I _{D1D2} = 10 A
Q _{GD2}	Gate-to-Drain2 Charge (V _{D2D1} =20V)		5.5			V _{D1} = 0, V _{D2} = 20 V, I _{D2D1} = 10 A
Q _{OSS}	Output Charge		8			V _G = 0 V, V _D = 20 V

9. Electric characteristics diagrams

at $T_j = 25\text{ °C}$, unless specified otherwise

Note: The device characteristics with D1 as drain and D2 as source is the same with D2 as drain and D1 as source.

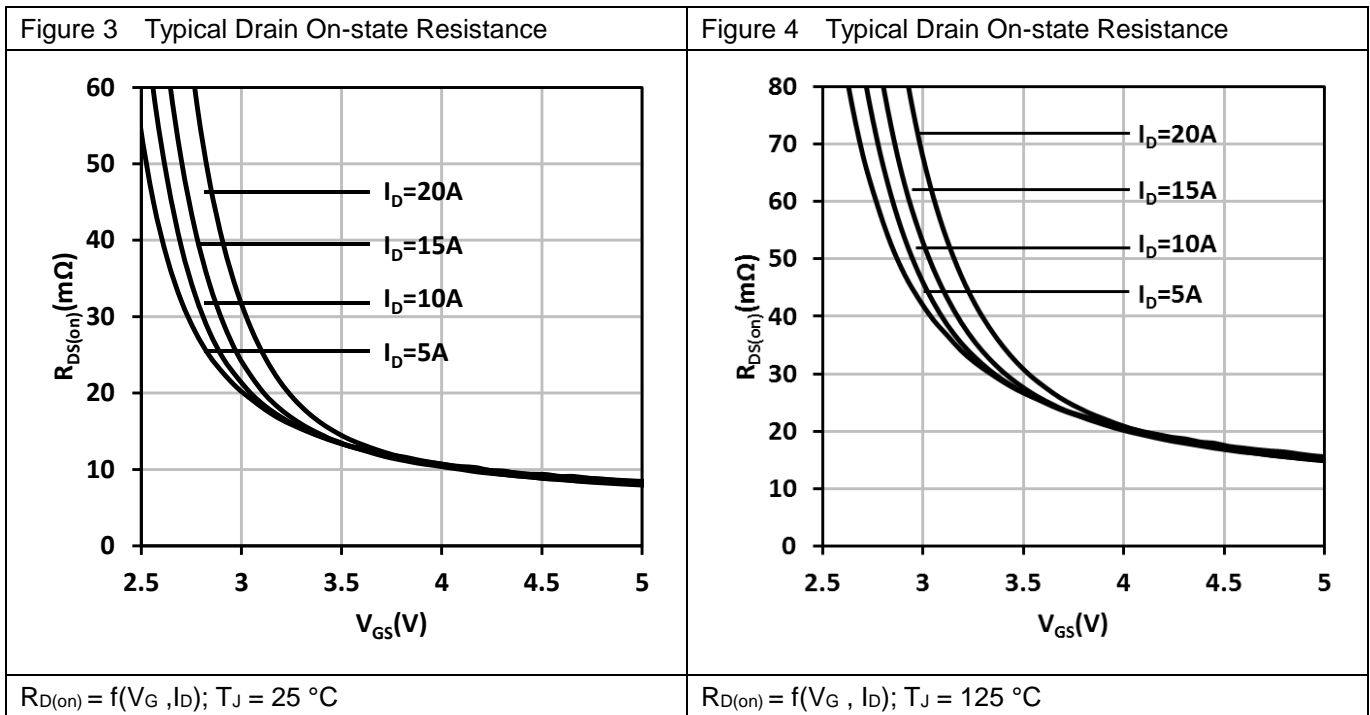
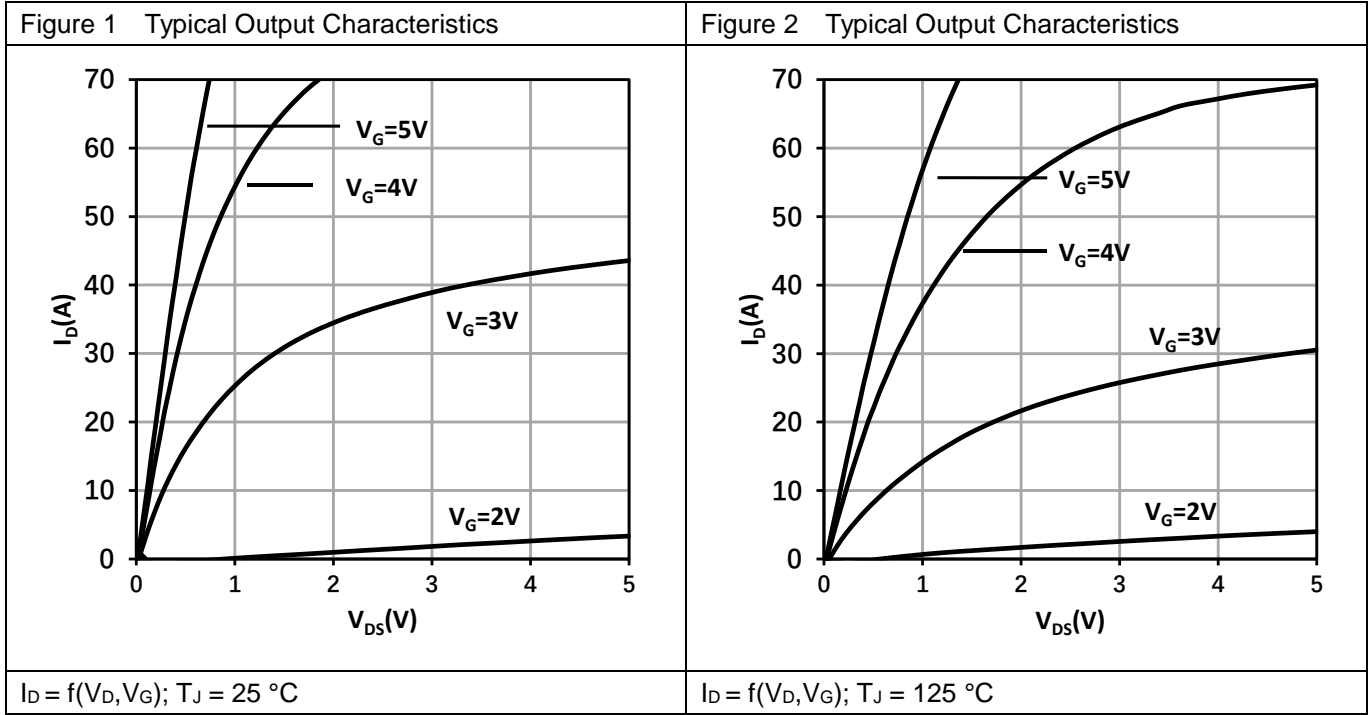
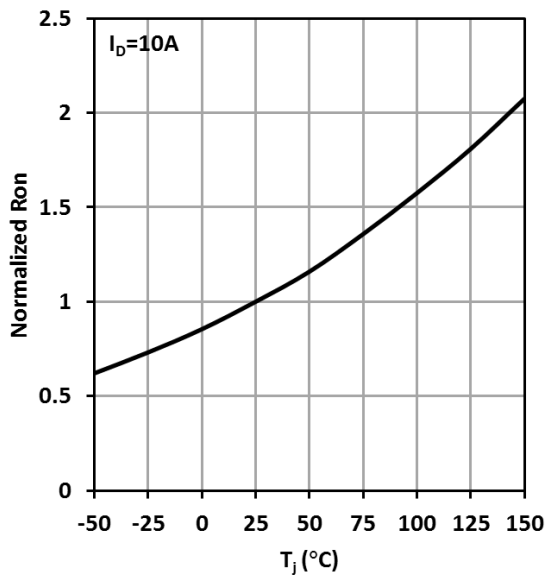
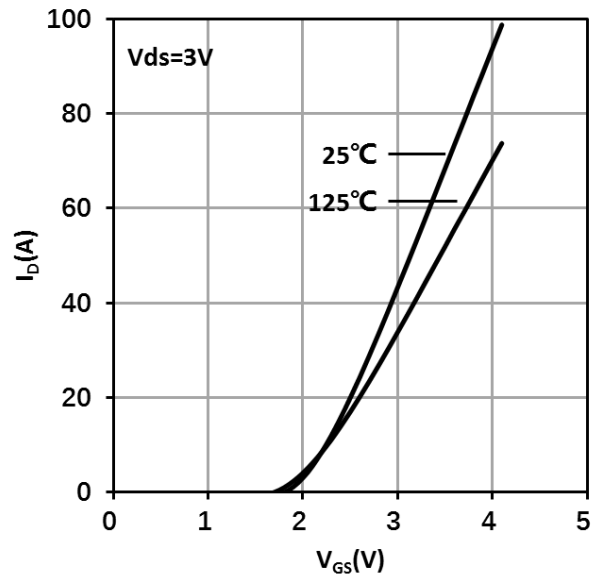

Figure 5 Typical On Resistance vs. Temperature



Normalized $R_{D(on)} = f(T_J)$; $I_D = 10\text{ A}$

Figure 6 Typical Transfer Characteristics



$I_D = f(V_{GS})$; $V_D = 3\text{ V}$

Fig. 7 Typ. Reverse Drain-Source Characteristics

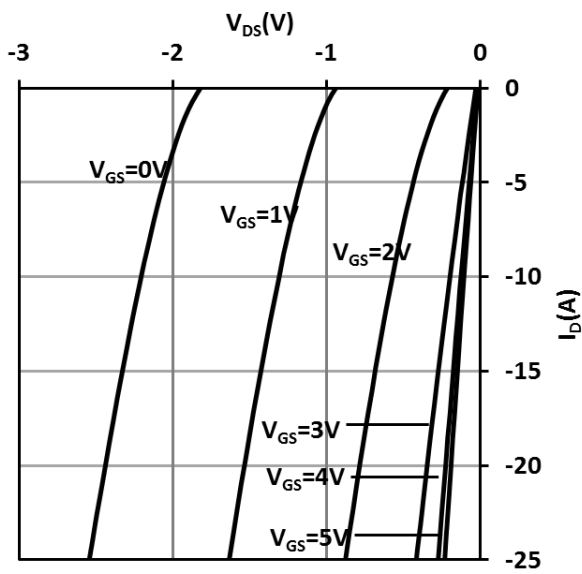

$I_D = f(V_D, V_{GS})$; $T_J = 25\text{ }^\circ\text{C}$

Fig. 8 Typ. Reverse Drain-Source Characteristics

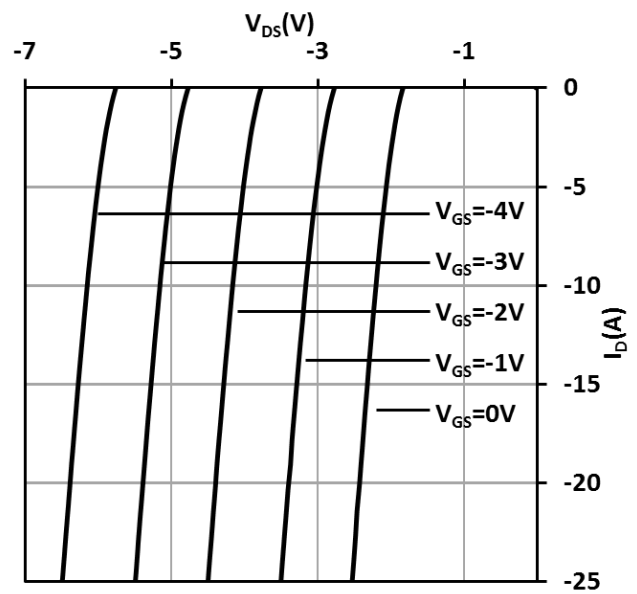

$I_D = f(V_D, V_{GS})$; $T_J = 25\text{ }^\circ\text{C}$

Fig. 9 Typ. Reverse Drain-Source Characteristics

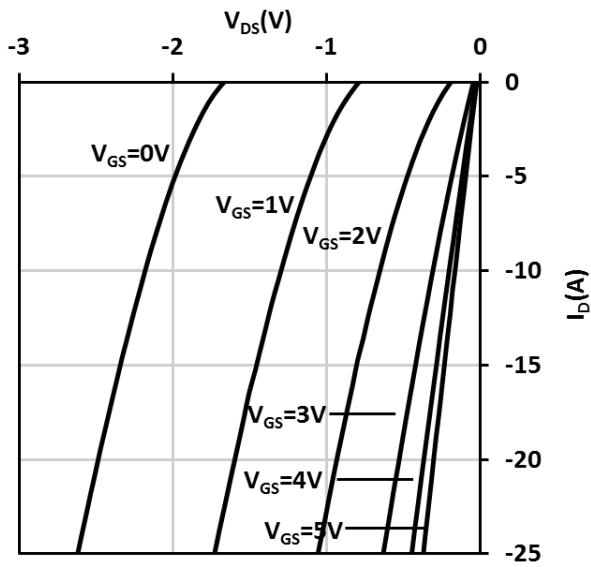

$I_D = f(V_D, V_G); T_J = 125\text{ }^\circ\text{C}$

Fig. 10 Typ. Reverse Drain-Source Characteristics

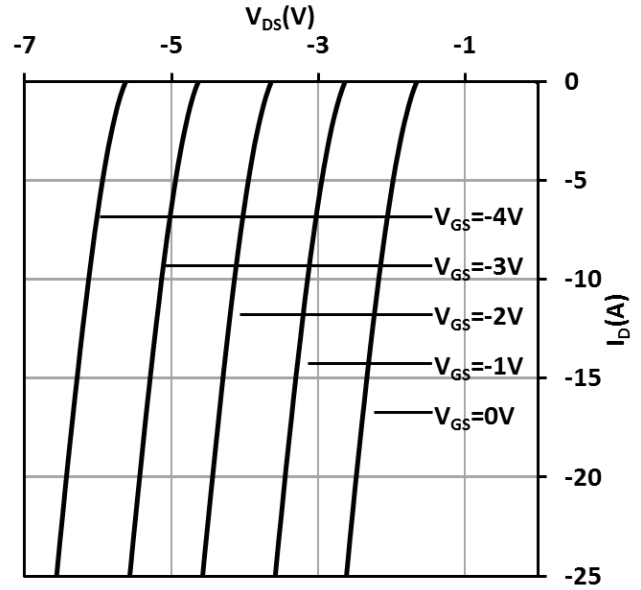

$I_D = f(V_D, V_G); T_J = 125\text{ }^\circ\text{C}$

Fig. 11 Typ. Capacitances Characteristics

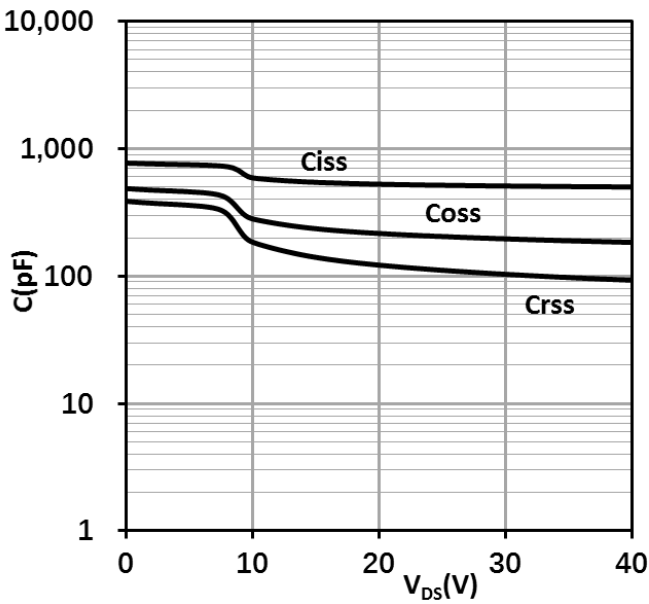

$C_{XSS} = f(V_D); f = 1\text{ MHz}$

Fig. 12 Typ. Gate Charge

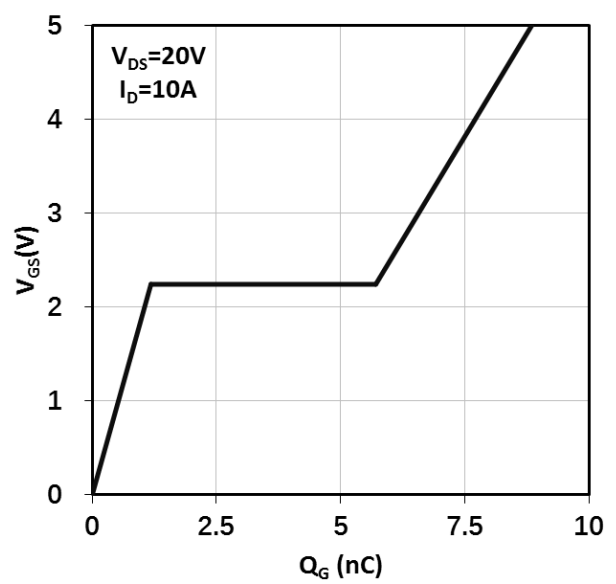

$V_G = f(Q_G); V_D = 20\text{ V}; I_D = 10\text{ A}$

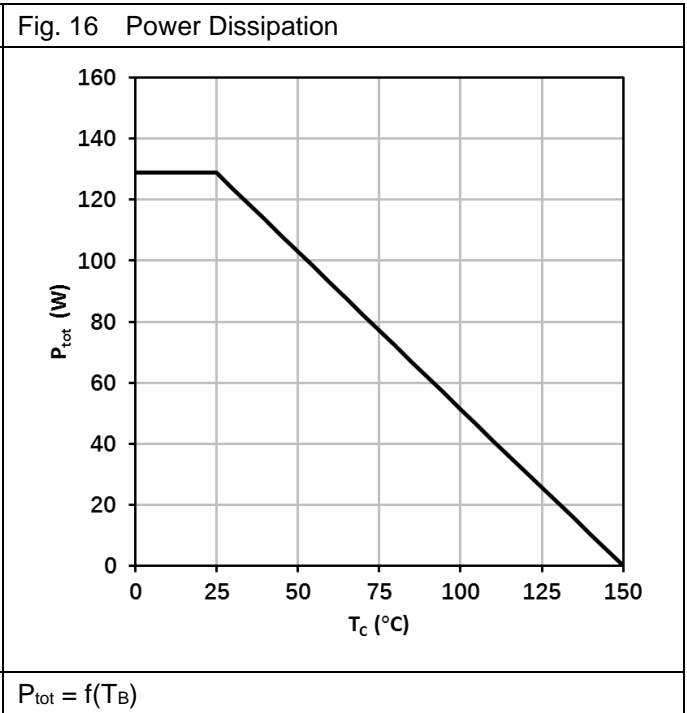
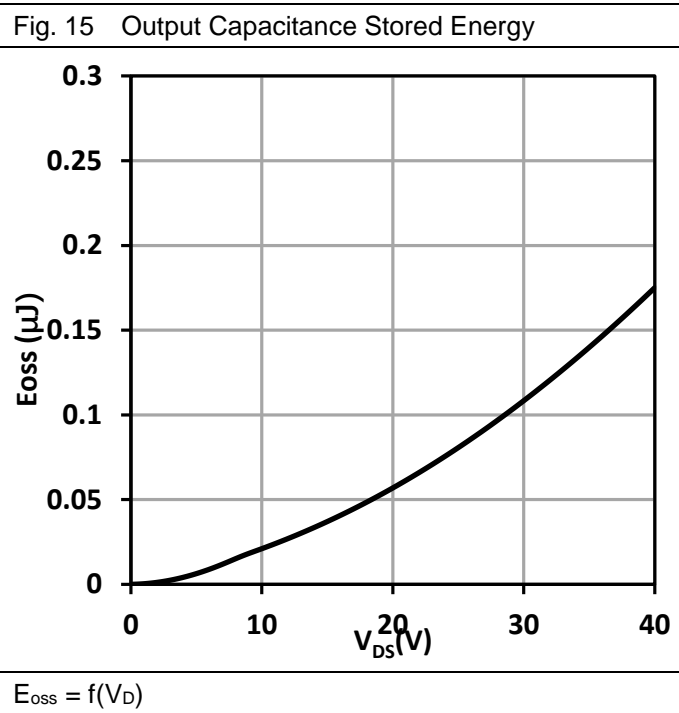
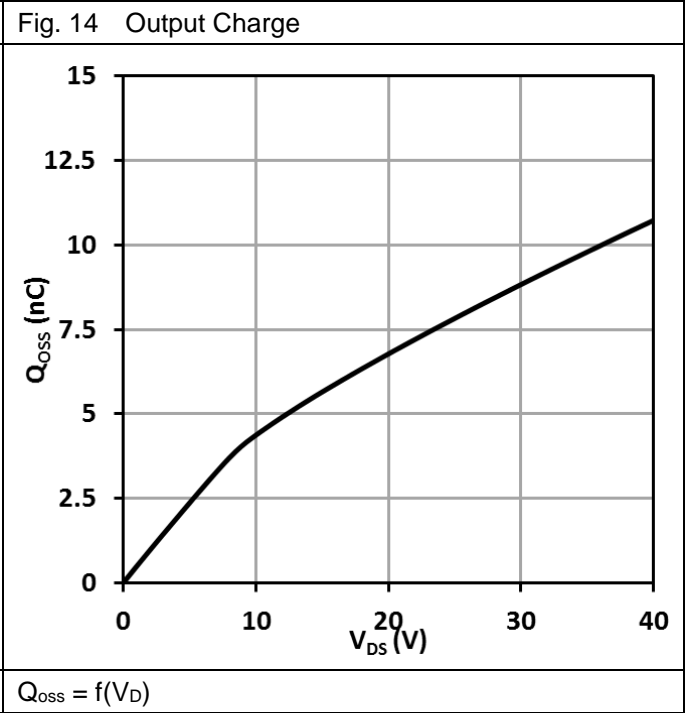
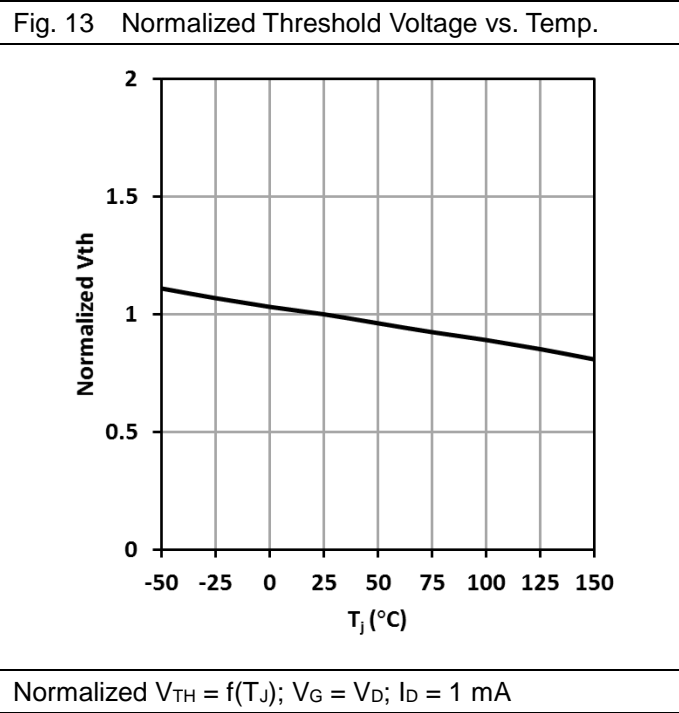
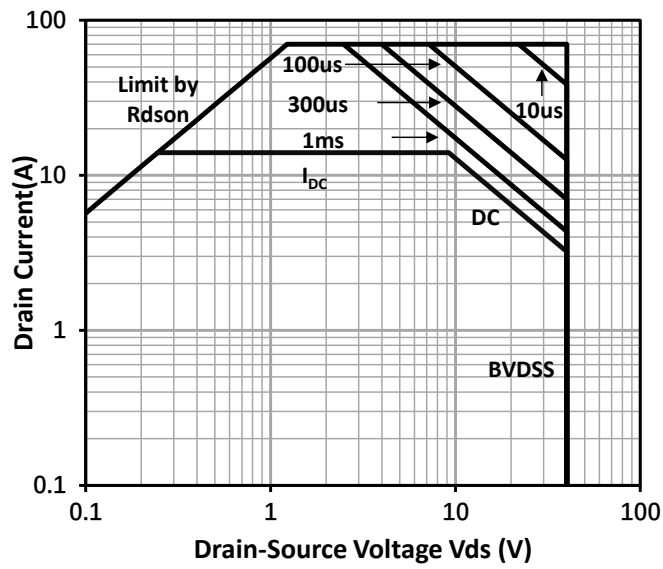
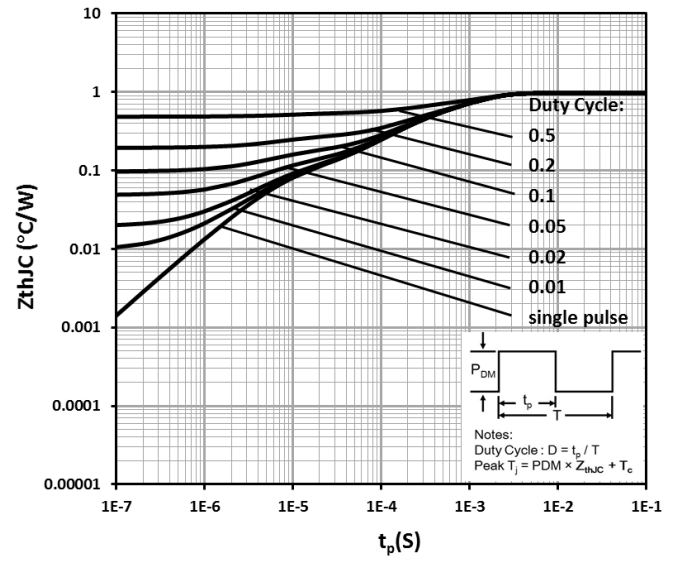

Fig. 17 Safe Operating Area



$I_D = f(V_D)$; $T_C = 25\text{ }^\circ\text{C}$; Single Pulse

Fig. 18 Max. Transient Thermal Impedance



$Z_{\theta JB} = f(t_p)$; parameter: $D = t_p / T$

10. Package outlines

Package Reference

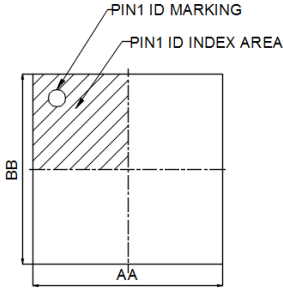

TOP VIEW

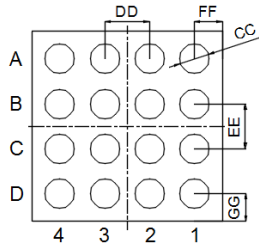

BOTTOM VIEW

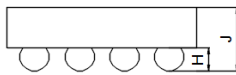

SIDE VIEW

SYMBOL	MILLIMETER			NOTE
	MIN	NOM	MAX	
AA	1.675	1.700	1.725	
BB	1.675	1.700	1.725	
CC	0.241	0.268	0.295	16X
DD	0.400 BASIC			12X
EE	0.400 BASIC			12X
FF	0.250 REF			4X
GG	0.250 REF			4X
H	0.175	0.205	0.235	
J	0.517	0.564	0.611	

NOTE:

- 1) ALL DIMENSION ARE IN MILLIMETERS.
- 2) BOTTOM VIEW IS SOLDER BALL VIEW.
- 3) COMPLIES WITH JEDEC MO-211.
- 4) DRAWING IS NOT TO SCALE.
- 5) A,B IS PACKAGE SIZE
- 6) BAR COPLANARITY SHALL BE 0.05 MILLIMETERS MAX

Marking Reference:

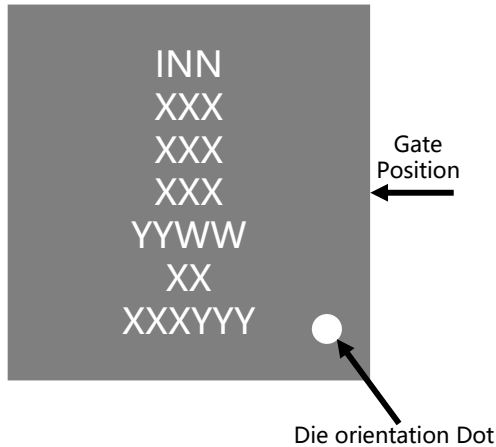

Row	Description	Example
Row 1	Company name	INN
Row 2	Product code	XXX
Row 3	Lot code	XXX
Row 4		XXX
Row 5	Date code	YYWW
Row 6	Wafer ID	XX
Row 7	Location ID	XXXYYY

11. Reel information

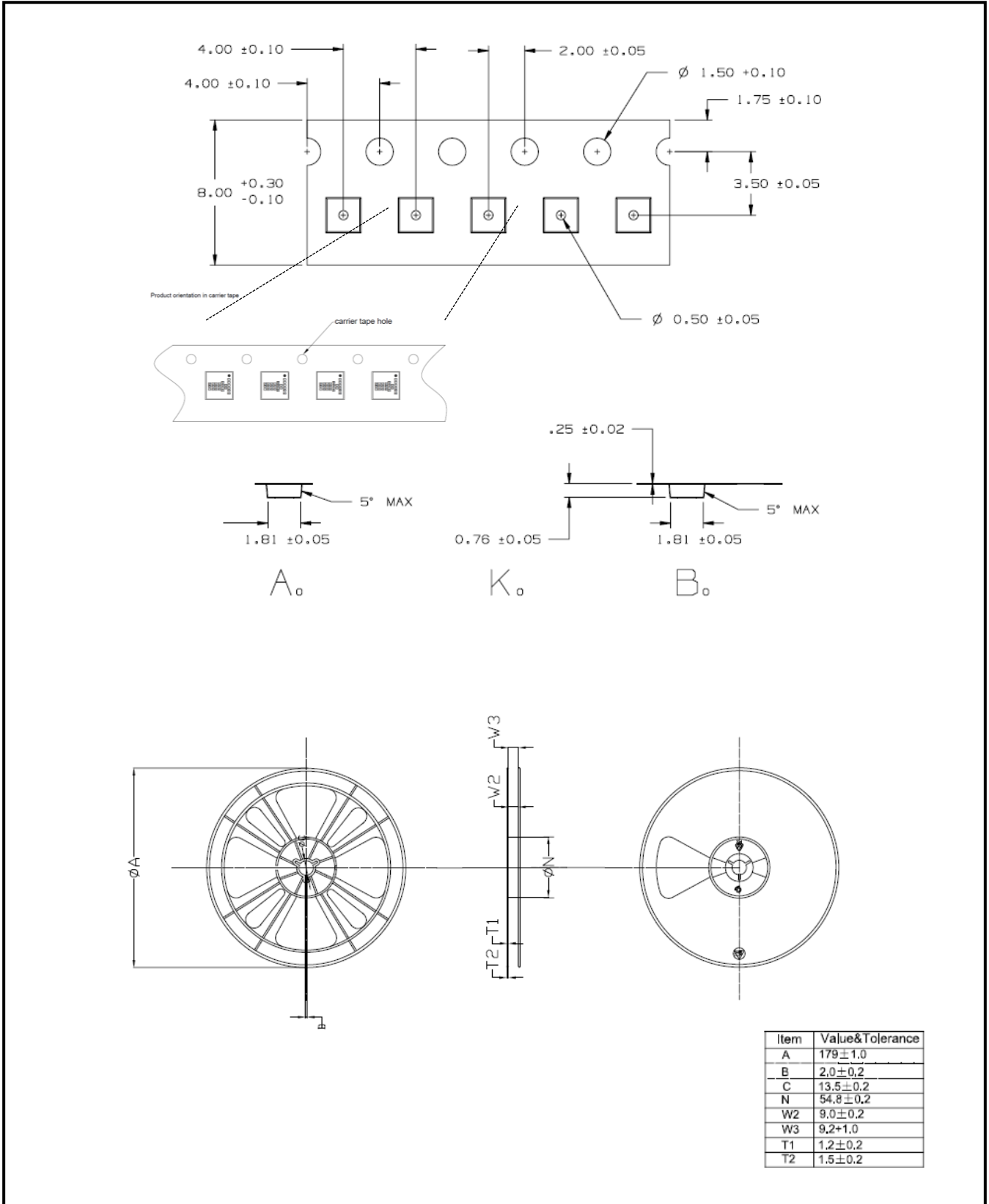

12. Land pattern

Recommended Land Pattern

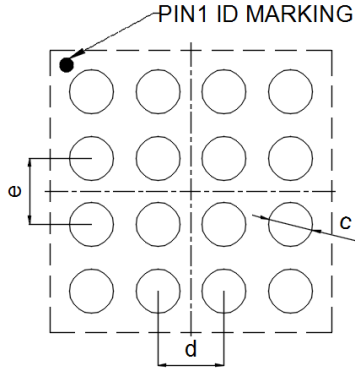

TOP VIEW

SYMBOL	MILLIMETER	NOTE
	NOM	
c	0.214	16X
d	0.400 BASIC	12X
e	0.400 BASIC	12X

Recommended Stencil Drawing

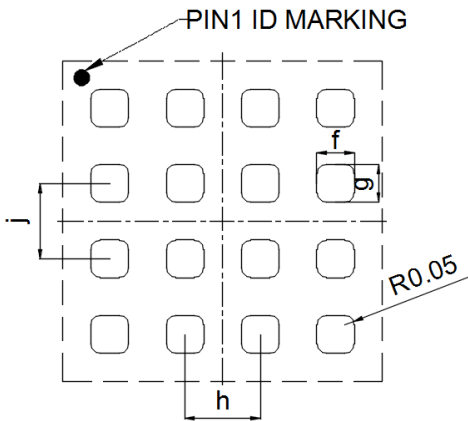

TOP VIEW

SYMBOL	MILLIMETER	NOTE
	NOM	
f	0.200	16X
g	0.200	16X
h	0.400 BASIC	12X
j	0.400 BASIC	12X

13. Revision history

Major changes since the last revision

Revision	Date	Description of changes
1.0	2023-01-10	1.0 version release

Important Notice

The information provided in this document is intended as a guide only and shall not in any event be regarded as a guarantee of conditions, characteristics or performance. Innoscience does not assume any liability arising out of the application or use of any product described herein, including but not limited to any personal injury, death, or property or environmental damage. No licenses, patent rights, or any other intellectual property rights is granted or conveyed. Innoscience reserves the right to modify without notice. All rights reserved.